



Truro Planning Board Agenda

Remote Meeting

Wednesday, October 12, 2022 – 5:00 pm

www.truro-ma.gov

TOWN OF TRURO
2:40 pm

OCT 05 2022

RECEIVED
TOWN CLERK

NS

Open Meeting

This will be a remote public meeting. Citizens can view the meeting on Channel 18 in Truro and on the web on the "Truro TV Channel 18" button under "Helpful Links" on the homepage of the Town of Truro website (www.truro-ma.gov). Click on the green "Watch" button in the upper right corner of the page. Please note that there may be a slight delay (approx. 15-30 seconds) between the meeting and the television broadcast/live stream.

Citizens can join the meeting to listen and provide public comment by entering the meeting link; clicking on the Agenda's highlighted link; clicking on the meeting date in the Event Calendar; or by calling in toll free at [1-866-899-4679](tel:1-866-899-4679) and entering the access code [406-228-413#](tel:406-228-413#) when prompted. Citizens will be muted upon entering the meeting until the public comment portion of the hearing. If you are joining the meeting while watching the television broadcast/live stream, please lower or mute the volume on your computer or television during public comment so that you may be heard clearly. Citizens may also provide written comment via postal mail or by emailing Liz Sturdy, Planning Department Administrator, at esturdy@truro-ma.gov.

Meeting link: <https://meet.goto.com/406228413>

Public Comment Period

The Commonwealth's Open Meeting Law limits any discussion by members of the Board of an issue raised to whether that issue should be placed on a future agenda. Speakers are limited to no more than 5 minutes.

1. Planner Report
2. Chair Report
3. Temporary Sign Permit Applications

Erik Spencer – First Parish Truro, for one (1) sign, 36" x 24", to be located on the southeast corner of Route 6 and Union Field Road. The sign will be installed on October 30th (Thanksgiving event) and removed December 26th (Christmas Eve event).

Board Action/Review (Continued)

2022-009/SPR – Crown Castle/T-Mobile, on property located at 344 Route 6 (Atlas Map 39, Parcel 172). Applicant seeks a Special Permit under Section 40.5 of the Truro Zoning Bylaw, and as an Eligible Facilities Request for a minor modification under Section 6409 and the rules of the Federal Communications Commission ("FCC"), to modify an existing tower: remove or replace antennas, ancillary equipment, and ground equipment as per plans for an existing carrier on an existing wireless communication facility; and replace equipment on existing concrete pad. Such modification will not substantially change the physical dimensions of such tower or base station. The modification does not constitute a substantial change to the existing tower under 47 C.F.R. §1.6100. [Material in 9/7/2022 packet] {New material included in this packet}

Board Action/Review (Continued)

2022-005/PB – Regan McCarthy seeks approval of Form A – Application for Determination that Plan Does Not Require Approval (ANR) pursuant to Section 2.2 of the Town of Truro Rules and Regulations Governing the Subdivision of Land with respect to property at 35A Higgins Hollow Road, Truro MA, Atlas Map 47, Parcel 2, Registry of Deeds title reference: Book 20807, Page 42. [Material in 8/24/2022 and 9/21/2022 packets]

Board Action/Review

2022-010/SPR – Crown Castle/DISH Wireless, on property located at 344 Route 6 (Atlas Map 39, Parcel 172). Applicant seeks a Special Permit under Section 40.5 of the Truro Zoning Bylaw, and as an Eligible Facilities Request for a minor modification under Section 6409 and the rules of the Federal Communications Commission (“FCC”), to modify an existing tower: adding three (3) antennas, six (6) remote radio units, and one (1) over voltage protection device at the 122’ centerline height on the tower, three (3) DC power cables, three (3) fiber trunks and one (1) radio cabinet in the existing fenced compound.

2022-006/PB – Matthew Bramble and Murray Bartlett seek approval of Form A – Application for Determination that Plan Does Not Require Approval (ANR) pursuant to Section 2.2 of the Town of Truro Rules and Regulations Governing the Subdivision of Land with respect to property at 31 and 33 Sylvan Lane, Truro MA, Atlas Map 43, Parcels 74 and 75, Registry of Deeds title reference: Books 33585 / 35191, Pages 120 / 48.

Development of Warrant Articles

- ◆ Updates
 - Street Definition
 - Lot Coverage/Site Clearing
 - Housing
 - Other

Interview of Potential Planning Board Members

- ◆ Confirm date & time
- ◆ Discuss potential questions from Planning Board

Minutes

- ◆ September 28, 2022 Work Session

Work Session: Wednesday, October 26, 2022 at 5:00 pm (Warrant Article)

Next Meeting: Wednesday, October 19, 2022 at 5:00 pm

Adjourn

TOWN OF TRURO
 2:40 PM
 OCT 05 2022
 RECEIVED
 TOWN CLERK
 NS

MEMORANDUM

To: Truro Planning Board

From: Barbara Carboni, Town Planner and Land Use Counsel

Date: October 11, 2022

Re: October 12, 2022 meeting

2022-009/SPR – Crown Castle for T-Mobile, on property located at 344 Route 6 (Atlas Map 39, Parcel 172), seeking a special permit under Section 40.5 of the Truro Zoning Bylaw and approval of an Eligible Facilities Request to remove certain equipment and install certain equipment on the cell tower.

Update: As the Board will remember, the Applicant was asked to have its engineer revisit the structural analysis submitted, modelling the proposed installation at the more demanding stress level (Risk Category III). The Applicant has submitted a revised Structural Analysis Report, which indicates that the tower and proposed equipment configuration have “Sufficient Capacity” to withstand such stress level.

Accordingly, the proposal may be approved with the Board’s standard conditions (e.g., requirement of removal of equipment from the tower and lot), and additional conditions reflecting the site’s sensitivity as occupied by Public Safety facility.

2022 2022-005/PB - Application (Form A) of Regan McCarthy for Determination that Plan Does Not Require Approval (ANR) under the Subdivision Control Law with respect to property known as 35A Higgins Hollow Road, located partly in the Seashore District and partly in the Residential District.

Update: As the Board will remember, the Applicant agreed to an extension of time for Board action on the ANR plan to allow the Applicant time to meet with the Cape Cod National Seashore regarding her rights under the Boundary Line Agreement and Right of Way permit. As of today, no additional materials have been received. Applicant’s counsel has been advised that there will be only five members present at the Board’s meeting.

2022-010/SPR – Crown Castle/DISH Wireless, on property located at 344 Route 6 (Atlas Map 39, Parcel 172), seeking a special permit¹ under Section 40.5 of the Truro Zoning Bylaw and approval of an Eligible Facilities Request to install certain equipment on the cell tower.

¹ The application references Site Plan Review, but the relief required is a special permit. A form briefly available online referenced Site Plan Review, but has since been corrected.

The proposal is to install three antennas, six remote radio units and one “over voltage protection device” at a height of 122 feet on the tower, and three cables, three fiber trunks and one radio cabinet in the existing structure.

The Structural Evaluation submitted with this application is a single page. It is stamped by a structural engineer licensed in Massachusetts. However, there is no indication of the Risk Category applied (as there is with the Crown Castle/T-Mobile Structural Analysis Report), and it was signed in July 2021. As a result, it is not clear whether the Structural Evaluation takes into consideration the factor of concern to the Board with respect to the T-Mobile application (Risk Category). The Board may seek further information from the Applicant regarding this factor.

2022-006/PB – Matthew Bramble and Murray Bartlett seek endorsement of an ANR plan with respect to property located at 31 and 33 Sylvan Lane (Atlas Map 43, Parcels 74 and 75)

The Applicant proposes to combine Lot 1 (31 Sylvan Lane, 88,358 square feet) and Lot 8 (33 Sylvan Lane, 31,332 square feet) as shown on the submitted Plan to form Lot 8A (total 119,690 square feet). Both are located in the Residential District; 31 Sylvan is unimproved; 33 Sylvan appears to be improved by a small structure. As requested by the Chair, the Applicant has provided additional information regarding the condition of Sylvan Lane. See email dated October 7, 2022.

The Form A states that an ANR endorsement is warranted where:

“The division of the tract of land shown on the accompanying plan is not a ‘subdivision’ because it shows a proposed conveyance/other instrument, namely [removing an interior lot line and combining into 1 lot] which adds to/takes a way from/changes the size and shape of, lots in such a manner that no lot affected is left without frontage as required by the Truro Zoning Bylaw under Section 50.1(A), which requires 150 feet.”

The resulting single Lot 8A would have over 150 feet of frontage on Sylvan Way, satisfying the above requirement.²

As the Board is aware, an ANR endorsement represents the Board’s finding that what is proposed is not a “subdivision” as that term is defined in G.L. c. 41. A combination of lots, as proposed here, is one appropriate use of the ANR procedure (subject to the frontage requirement above). There would not appear to be any obstacles to endorsement of the Plan as Approval Not Required.

² A note on the Plan appropriately notes that the Planning Board’s endorsement does not indicate that the lot is buildable or that it meets zoning, health, or general bylaw requirements.

TOWN OF TRURO



Application for Temporary Sign Permit

Pursuant to Section 11 of the Truro Sign Code

Fee: \$25.00 (for each 30-day period)

Applicant Name: Erik Spencer for First Parish, Truro Date: Sept 26, 2022

Applicant Contact Information: 111 Whidah Way Wellfleet MA 02667
Mailing Address
508-214-0083 Phone espencer10@verizon.net Email

Number of Signs Requested: 1

Temporary Sign Dimensions:

- (1) Height 36" Width 24"
- (2) Height _____ Width _____
- (3) Height _____ Width _____
- (4) Height _____ Width _____

Location(s) of Proposed Temporary Sign(s): South east corner of Rt 6 and Union Field Rd

Date(s) of the Event in Which the Sign is Intended: Nov. 24, 2022 Thanksgiving

Date When Sign(s) will be: Installed: Oct 30, 2022 Removed: Nov 25, 2022

Applicant Signature Erik Spencer Date 9/26/22
Applicant Printed Name Erik Spencer

If sign(s) to be placed on private property, please have Owner print and sign name below:

Owner Signature _____ Date _____
(which also authorizes the use of the property)
Owner Printed Name _____

Planning Board Action: Approved _____ Approved w/Conditions _____ Denied _____

Conditions: _____

Board Signature: _____ Date: _____
Chair, Planning Board

**FIRST PARISH
TRURO.COM**



**T - G I V I N G
M O R N I N G**

10am

**T H A N K S G I V I N G
S E R V I C E**

TOWN OF TRURO



Application for Temporary Sign Permit

Pursuant to Section 11 of the Truro Sign Code

Fee: \$25.00 (for each 30-day period)

Applicant Name: Erik Spencer for First Parish, Truro Date: Sept 26, 2022

Applicant Contact Information: 111 Whidah Way, Wellfleet MA 02667
508-214-0083 Phone
espenccr10@verizon.net Email

Number of Signs Requested: 1

Temporary Sign Dimensions:

- (1) Height 36 Width 24
(2) Height Width
(3) Height Width
(4) Height Width

Location(s) of Proposed Temporary Sign(s): South east corner of Rt6 and Union Field Rd

Date(s) of the Event in Which the Sign is Intended: Dec 24, 2022 Christmas Eve

Date When Sign(s) will be: Installed: Nov 25, 2022 Removed: Dec. 26, 2022

Applicant Signature: Erik Spencer Date: 9/26/22
Applicant Printed Name: Erik Spencer

If sign(s) to be placed on private property, please have Owner print and sign name below:

Owner Signature: (which also authorizes the use of the property) Date
Owner Printed Name:

Planning Board Action: Approved Approved w/Conditions Denied

Conditions:

Board Signature: Chair, Planning Board Date:

**FIRST PARISH
TRURO.COM**



**CHRISTMAS
EVE**

4pm

**CANDLELIGHT
SERVICE**



Date: **September 21, 2022**

B+T Group
1717 S, Boulder, Suite 300
Tulsa, OK 74119
(918) 587-4630

Subject: **Structural Analysis Report**

Carrier Designation: **Site Number:** 4HY0568A
Site Name: BS13XC597

Crown Castle Designation: **BU Number:** 841273
Site Name: TRURO
JDE Job Number: 723038
Work Order Number: 2161774
Order Number: 623577 Rev. 1

Engineering Firm Designation: **B+T Group Project Number:** 100736.010.01.0001

Site Data: **344 Route 6, North Truro, Barnstable County, MA**
Latitude 42° 1' 18", Longitude -70° 4' 30"
170 Foot - Self Support Tower

B+T Group is pleased to submit this “**Structural Analysis Report**” to determine the structural integrity of the above-mentioned tower.

The purpose of the analysis is to determine acceptability of the tower stress level. Based on our analysis we have determined the tower stress level for the structure and foundation, under the following load case, to be:

LC7: Proposed Equipment Configuration

Sufficient Capacity

This analysis utilizes an ultimate 3-second gust wind speed of 149 mph as required by the 2015 International Building Code as amended by the Massachusetts State Building Code, Ninth Edition. Applicable Standard references and design criteria are listed in Section 2 - Analysis Criteria.

Structural analysis prepared by: Andrew Fisher

Respectfully submitted by: B+T Engineering, Inc.

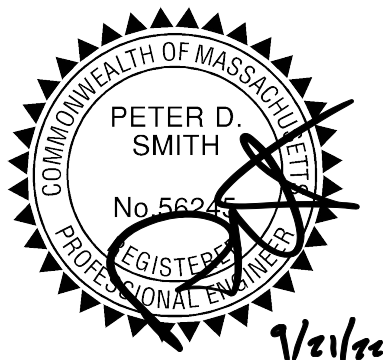

Peter Smith, P.E.

TABLE OF CONTENTS

1) INTRODUCTION

2) ANALYSIS CRITERIA

Table 1 - Proposed Equipment Configuration

Table 2 - Other Considered Equipment

3) ANALYSIS PROCEDURE

Table 3 - Documents Provided

3.1) Analysis Method

3.2) Assumptions

4) ANALYSIS RESULTS

Table 4 - Section Capacity (Summary)

Table 5 – Tower Component Stresses vs. Capacity – LC7

4.1) Recommendations

5) APPENDIX A

tnxTower Output

6) APPENDIX B

Base Level Drawing

7) APPENDIX C

Additional Calculations

1) INTRODUCTION

This tower is a 170 ft. Self-Support tower designed by Sabre and mapped by GPD Group.

2) ANALYSIS CRITERIA

TIA-222 Revision:	TIA-222-H
Risk Category:	III
Wind Speed:	149 mph
Exposure Category:	C
Topographic Factor:	1
Ice Thickness:	1.5 in
Wind Speed with Ice:	50 mph
Service Wind Speed:	60 mph

Table 1 - Proposed Equipment Configuration

Mounting Level (ft)	Center Line Elevation (ft)	Number of Antennas	Antenna Manufacturer	Antenna Model	Number of Feed Lines	Feed Line Size (in)
168.0	169.0	3	Ericsson	4003_840590966_TMO	3	1-5/8
		3	Ericsson	AIR 6419 B41_TMO		
		3	Ericsson	RADIO 4460 B2/B25 B66_TMO		
		3	Ericsson	Radio 4480_TMOV2		
		3	Rfs Celwave	APXVLL19P_43-C-A20_TMO		
	168.0	3	Site Pro1	VFA12-HD Mount		
71.0	73.0	1	Pctel	GPS-TMG-HR-26N	1	1/2
	71.0	1	--	Side Arm Mount [SO 601-1]		

Table 2 - Other Considered Equipment

Mounting Level (ft)	Center Line Elevation (ft)	Number of Antennas	Antenna Manufacturer	Antenna Model	Number of Feed Lines	Feed Line Size (in)
170.0	174.0	1	Decibel	DB806-XC	1	1/2
160.0	162.0	1	Shively Labs	6813-2 HW	1	1-5/8
	160.0	1	--	Side Arm Mount [SO 305-1]		
151.0	151.0	4	Powerwave Tech.	P65.15.XL.0	2	1-1/4
		2	--	Sector Mount [SM 602-1]		
145.0	145.0	6	Ericsson	RRUS 11	12	1-5/8
		3	Ericsson	RRUS 32		
		3	Ericsson	RRUS 32 B66		
		6	Kaelus	DBC0061F1V51-2		
		3	Kathrein	800 10122		
		12	Kathrein	860 10025		
		3	Kmw Comm.	AM-X-CD-16-65-00T-RET		
		6	Powerwave Tech.	LGP21401		
		3	Quintel Tech.	QS66512-2		
		2	Raycap	DC6-48-60-18-8F		
1	--	Sector Mount [SM 702-3]	4	5/8		
				2	3/8	

Mounting Level (ft)	Center Line Elevation (ft)	Number of Antennas	Antenna Manufacturer	Antenna Model	Number of Feed Lines	Feed Line Size (in)	
139.0	139.0	1	--	Pipe Mount [PM 601-1]	1	EW52	
	138.0	1	Andrew	PAR6-59A			
130.0	131.0	3	Alcatel Lucent	RRH2X60-AWS	19	1-5/8	
		3	Commscope	HBXX-6516DS-A2M			
		3	Commscope	LNx-6514DS-A1M			
		3	Commscope	SBNHH-1D65B			
		2	CSS	X7C-665-2			
		1	CSS	X7C-680-2			
	2	Rfs Celwave	DB-B1-6C-12AB-0Z				
	130.0	1	--	Sector Mount [SM 702-3]			
122.0	122.0	1	--	Commscope MTC3975083 (3)	1	1-1/2	
		3	Fujitsu	TA08025-B604			
		3	Fujitsu	TA08025-B605			
		3	Jma Wireless	MX08FRO665-21			
		1	Raycap	RDIDC-9181-PF-48			
104.0	117.0	1	Rfs Celwave	PD220-5	10 8	7/8 3/8	
	116.0	1	Telewave	ANT150F6			
	114.0	1	Sinclair	SRL-210C-4			
	113.0	1	Decibel	DB540K-F			
	112.0	2	Rfs Celwave	AO8610-5T0			
	107.0	1	Kathrein	K751221			
	106.0		2	Commscope			VHLPX4-11W-6WH
			1	Rfs Celwave			10191
			1	Telewave			ANT150F2
104.0	1	--	Sabre 30' Specialty Platform				
96.0	97.0	3	Ericsson	ERICSSON AIR 21 B4A B2P	3 6 2	1-1/4 7/8 3/8	
		3	Ericsson	RADIO 4449 B12/B71			
		3	Ericsson	RRUS 11 B2			
		3	Rfs Celwave	APXVAARR24_43-U-NA20			
		3	Rfs Celwave	ATM1900D-1A20			
	96.0	1	--	Sector Mount [SM 403-3]			
87.0	87.0	1	Scala	PR-950	1	1/2	
		1	--	Side Arm Mount [SO 201-1]			

3) ANALYSIS PROCEDURE

Table 3 - Documents Provided

Document	Reference	Source
Tower Manufacturer Drawing	4287353	CCI Sites
Foundation Drawing	4468581	CCI Sites
Geotech Report	4287355	CCI Sites
Crown CAD Package	Date: 06/28/2022	CCI Sites

3.1) Analysis Method

tnxTower (version 8.1.1.0), a commercially available analysis software package, was used to create a three-dimensional model of the tower and calculate member stresses for various loading cases. Selected output from the analysis is included in Appendix A. When applicable, Crown Castle has calculated and provided the effective area for panel antennas using approved methods following the intent of the TIA-222 standard.

3.2) Assumptions

- 1) The tower and structures were maintained in accordance with the - TIA-222 standard.
- 2) The configuration of antennas, transmission cables, mounts and other appurtenances are as specified in Tables 1 and 2 and the referenced drawings.

This analysis may be affected if any assumptions are not valid or have been made in error. B+T Group should be notified to determine the effect on the structural integrity of the tower.

4) ANALYSIS RESULTS

Table 4 - Section Capacity (Summary)

Section No.	Elevation (ft)	Component Type	Size	Critical Element	P (K)	SF*P_allow (K)	% Capacity	Pass / Fail
T1	170 - 160	Leg	Sabre 3.5" x 0.216"	1	-7.736	86.635	8.9	Pass
T2	160 - 140	Leg	Sabre 4.5" x 0.438"	19	-40.935	210.881	19.4	Pass
T3	140 - 120	Leg	Sabre 6.625" x 0.432"	40	-95.003	360.255	26.4	Pass
T4	120 - 100	Leg	Sabre 8.625" x 0.5"	62	-160.765	569.808	28.2	Pass
T5	100 - 80	Leg	Sabre 10.750" x 0.500"	83	-231.538	702.092	33.0	Pass
T6	80 - 60	Leg	Sabre 12.75" x 0.5"	99	-310.146	859.488	36.1	Pass
T7	60 - 40	Leg	Sabre 16" x 0.5"	114	-389.310	1110.690	35.1	Pass
T8	40 - 20	Leg	Sabre 18" x 0.5"	129	-467.770	1263.528	37.0	Pass
T9	20 - 0	Leg	Sabre 18" x 0.5"	144	-523.334	1289.925	40.6	Pass
T1	170 - 160	Diagonal	L2x2x3/8	12	-3.354	18.112	18.5	Pass
T2	160 - 140	Diagonal	L3x3x3/8	22	-8.889	40.506	21.9	Pass
T3	140 - 120	Diagonal	L3 1/2x3 1/2x3/8	44	-12.897	51.321	25.1	Pass
T4	120 - 100	Diagonal	L3 1/2x3 1/2x1/2	68	-15.693	53.678	29.2	Pass
T5	100 - 80	Diagonal	L5x5x1/2	89	-21.079	105.471	20.0	Pass
T6	80 - 60	Diagonal	L5x5x5/8	104	-22.481	116.354	19.3	Pass
T7	60 - 40	Diagonal	L5x5x5/8	119	-24.079	101.338	23.8	Pass
T8	40 - 20	Diagonal	L5x5x5/8	134	-26.567	87.432	30.4	Pass
T9	20 - 0	Diagonal	L5x5x5/8	160	-34.851	123.179	28.3	Pass
T9	20 - 0	Horizontal	2L3 1/2x3 1/2x1/4x3/8	159	-25.174	40.214	62.6	Pass
T1	170 - 160	Top Girt	L2 1/2x2 1/2x3/16	4	-0.291	8.385	3.5	Pass
T9	20 - 0	Redund Horz 1 Bracing	L3x3x5/16	157	-9.076	43.079	21.1	Pass
T9	20 - 0	Redund Diag 1 Bracing	L3x3x1/4	158	-5.764	23.979	24.0	Pass
T9	20 - 0	Inner Bracing	L3x3x3/16	166	-0.033	5.612	0.8	Pass
							Summary	
						Leg (T9)	40.6	Pass
						Diagonal (T8)	30.4	Pass

Section No.	Elevation (ft)	Component Type	Size	Critical Element	P (K)	SF*P_allow (K)	% Capacity	Pass / Fail
						Horizontal (T9)	62.6	Pass
						Top Girt (T1)	3.5	Pass
						Redund Horz 1 Bracing (T9)	21.1	Pass
						Redund Diag 1 Bracing (T9)	24.0	Pass
						Inner Bracing (T9)	0.8	Pass
						Bolt Checks	76.5	Pass
						Rating =	76.5	Pass

Table 5 - Tower Component Stresses vs. Capacity – LC7

Notes	Component	Elevation (ft)	% Capacity	Pass / Fail
1,2	Anchor Rods	Base	30.8	Pass
1,2	Base Foundation (Structure)	Base	11.9	Pass
1,2	Base Foundation (Soil Interaction)	Base	62.6	Pass

Structure Rating (max from all components) =	76.5%
---	--------------

Notes:

- 1) See additional documentation in "Appendix C – Additional Calculations" for calculations supporting the % capacity consumed.
- 2) Rating per TIA-222-H Section 15.5.

4.1) Recommendations

The tower and its foundation have sufficient capacity to carry the proposed load configuration. No modifications are required at this time.

APPENDIX A
TNXTOWER OUTPUT

Plot Plan
Total Area - 0.07 Acres

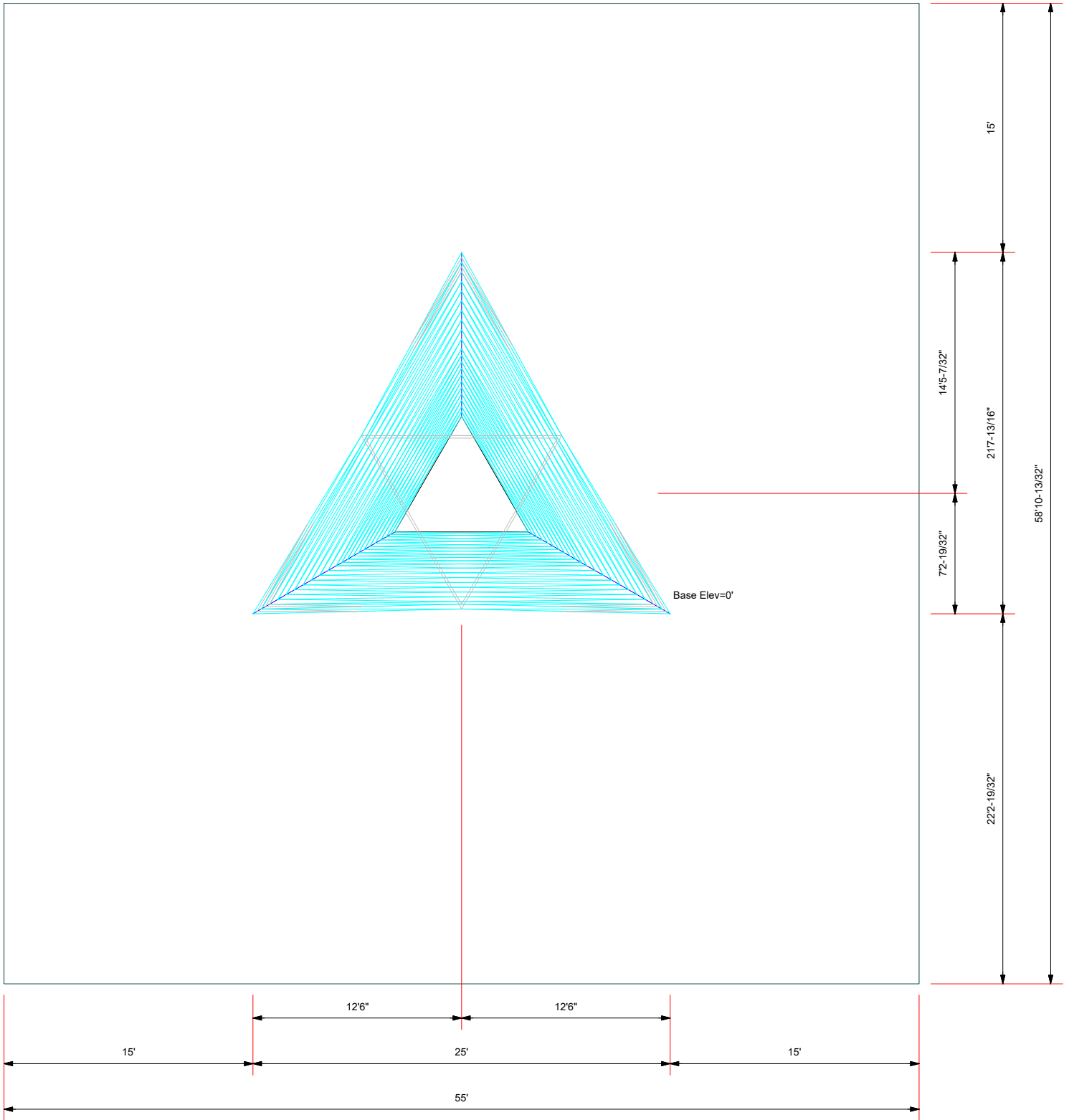

B+T Group
 1717 S, Boulder, Suite 300
 Tulsa, OK 74119
 Phone: (918) 587-4630
 FAX: (918) 587-4630

Job: 100736.010.01.0001 - TRURO, MA (BU# 841273)		
Project:		
Client: Crown Castle	Drawn by: Nithish Acharya	App'd:
Code: TIA-222-H	Date: 09/21/22	Scale: NTS
Path:	Dwg No. E-2	

TIA-222-H - 149 mph/50 mph 1.500 in Ice Exposure C

Leg Capacity ———
Leg Compression (K)

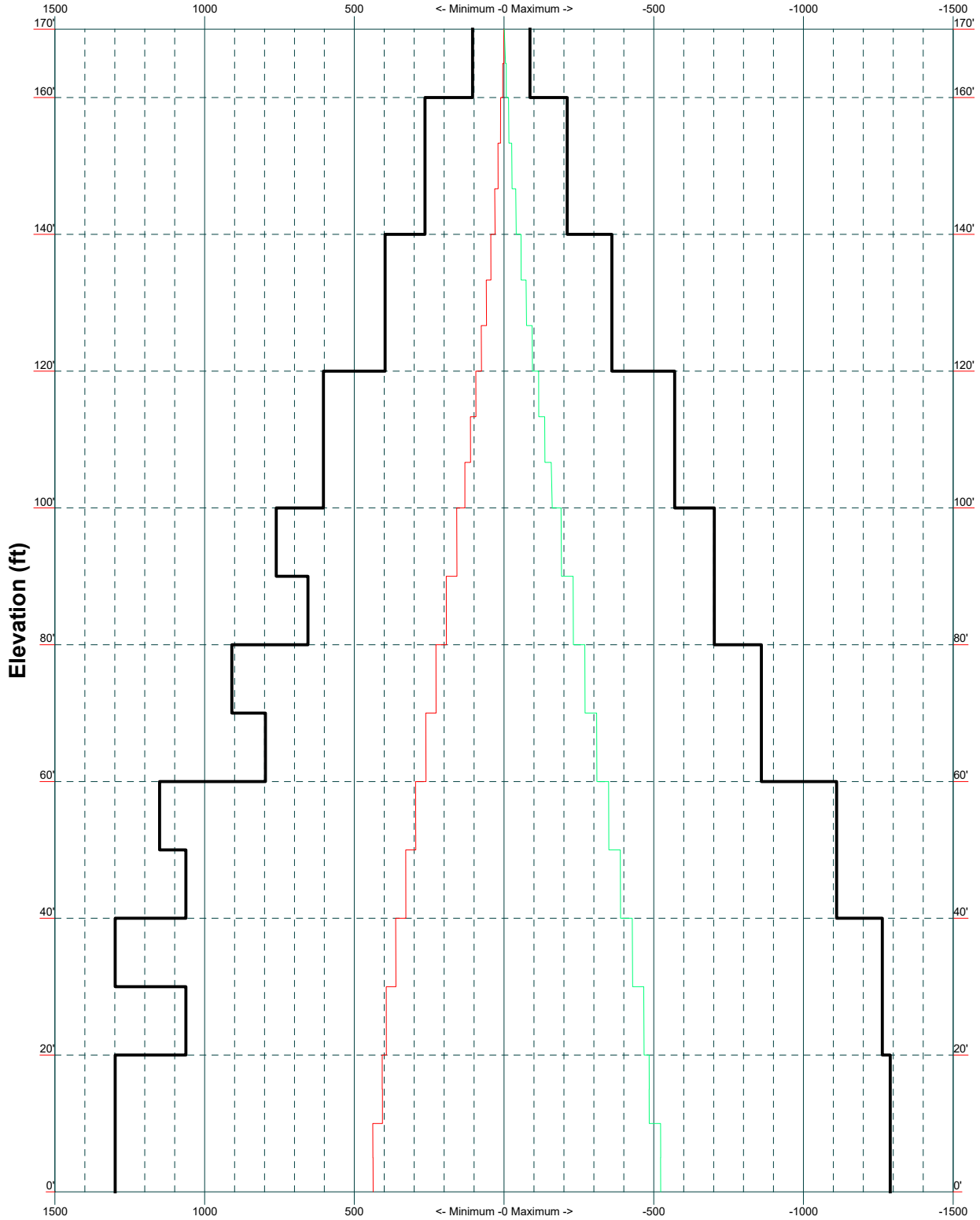

B+T Group
 1717 S, Boulder, Suite 300
 Tulsa, OK 74119
 Phone: (918) 587-4630
 FAX: (918) 587-4630

Job: 100736.010.01.0001 - TRURO, MA (BU# 841273)		
Project:		
Client: Crown Castle	Drawn by: Nithish Acharya	App'd:
Code: TIA-222-H	Date: 09/21/22	Scale: NTS
Path:		Dwg No. E-3

C:\Users\j20205\Desktop\SA\Sep 21\100736_841273_Trop...Nithish...Siva\Trop 010 01 001\100736_010 01 001_TRURO MA.dwg

Vx Vz

Mx Mz

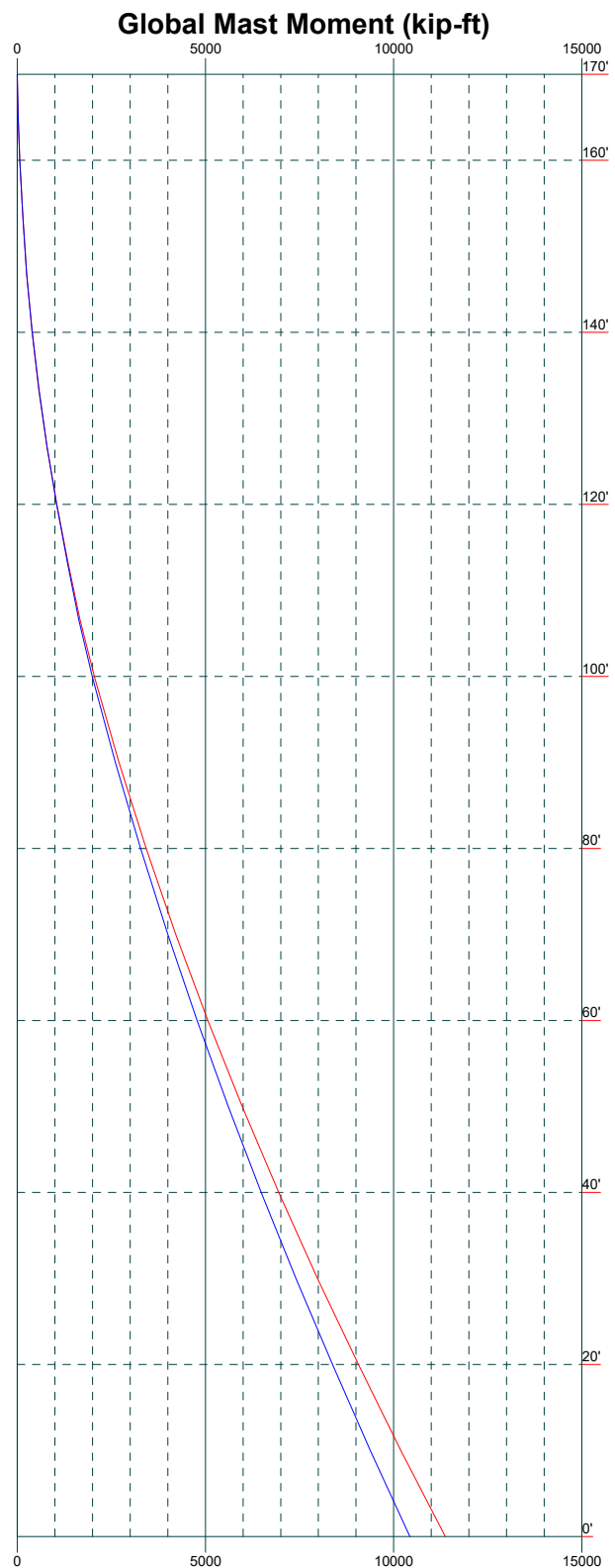
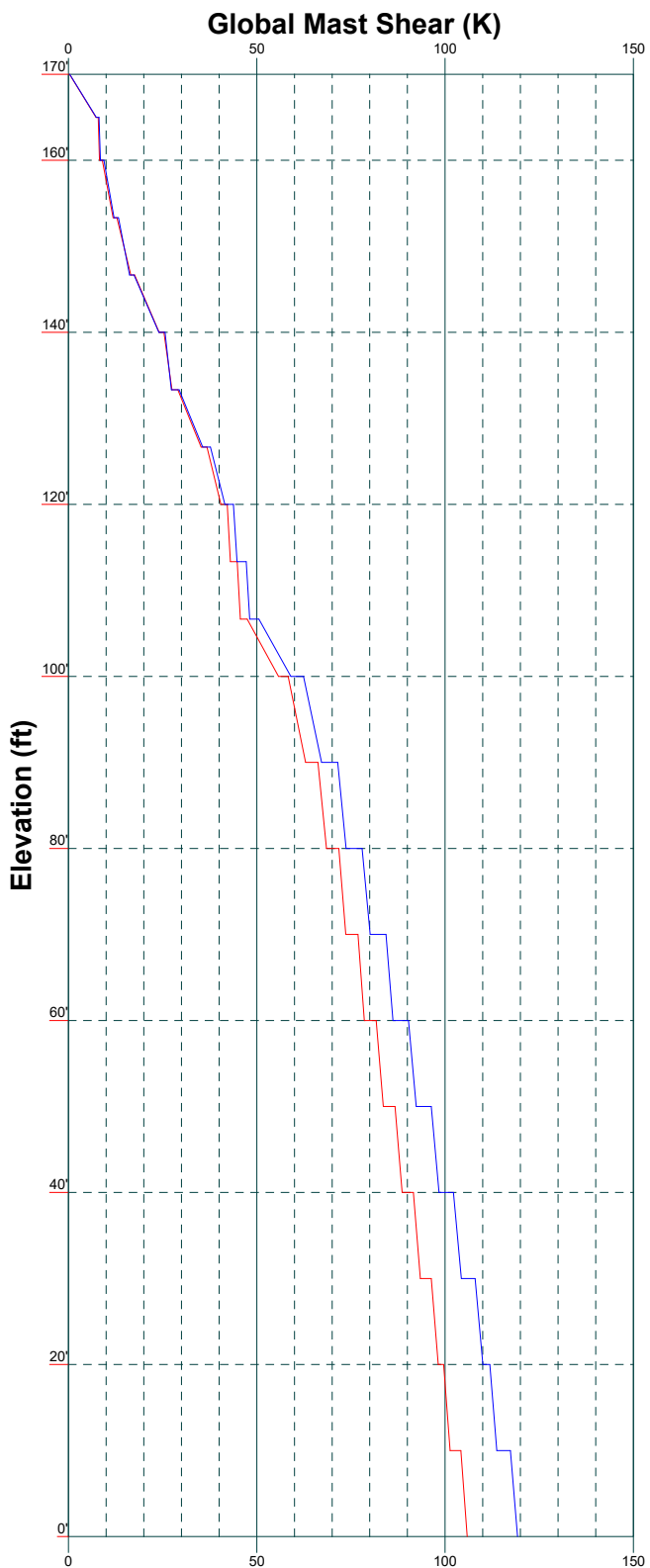

B+T Group
 1717 S. Boulder, Suite 300
 Tulsa, OK 74119
 Phone: (918) 587-4630
 FAX: (918) 587-4630

Job: 100736.010.01.0001 - TRURO, MA (BU# 841273)		
Project:		
Client: Crown Castle	Drawn by: Nithish Acharya	App'd:
Code: TIA-222-H	Date: 09/21/22	Scale: NTS
Path:	Dwg No. E-4	

C:\Users\N02006\Desktop\SAI\Sep 21\100736_841273_Turp...Nithish...Siva\Twp 010 01 001\100736_010 01 001_TRURO_M.dwg

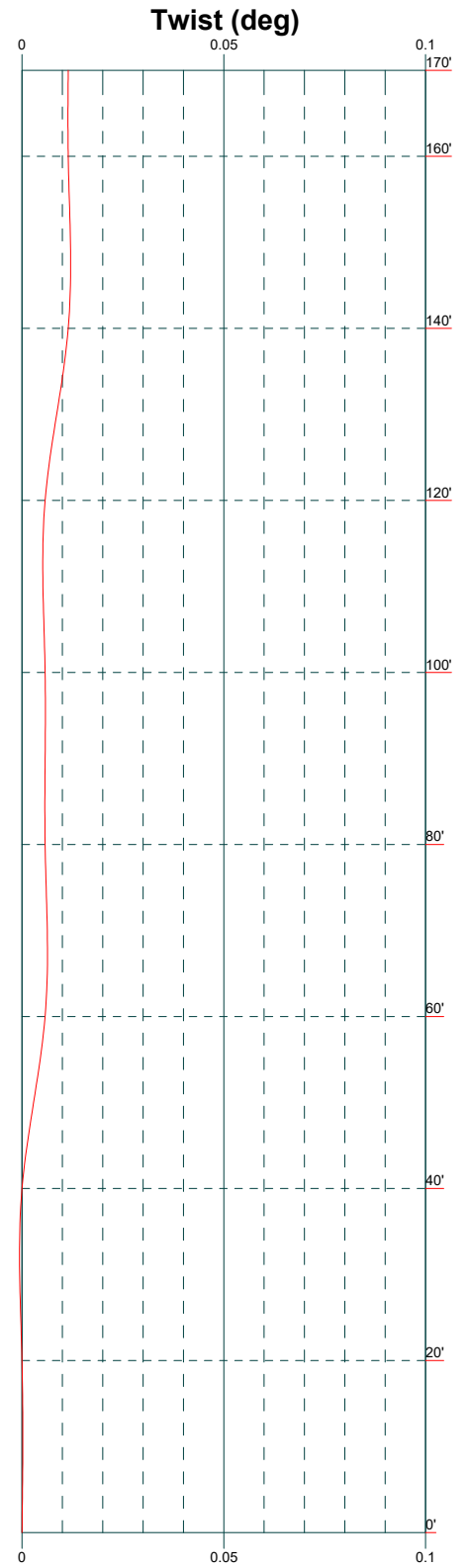
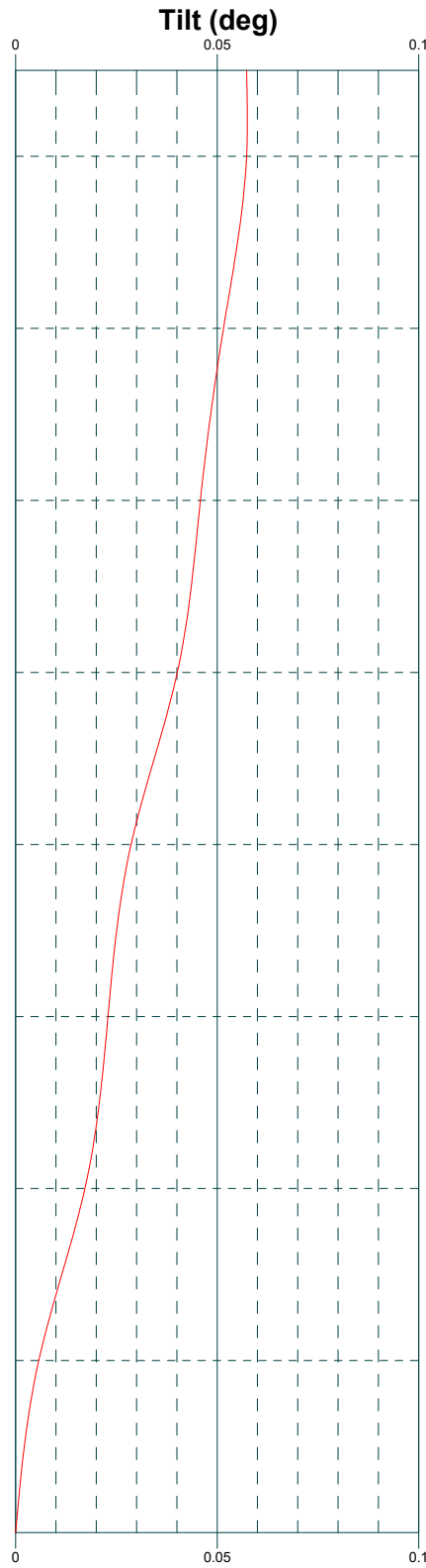
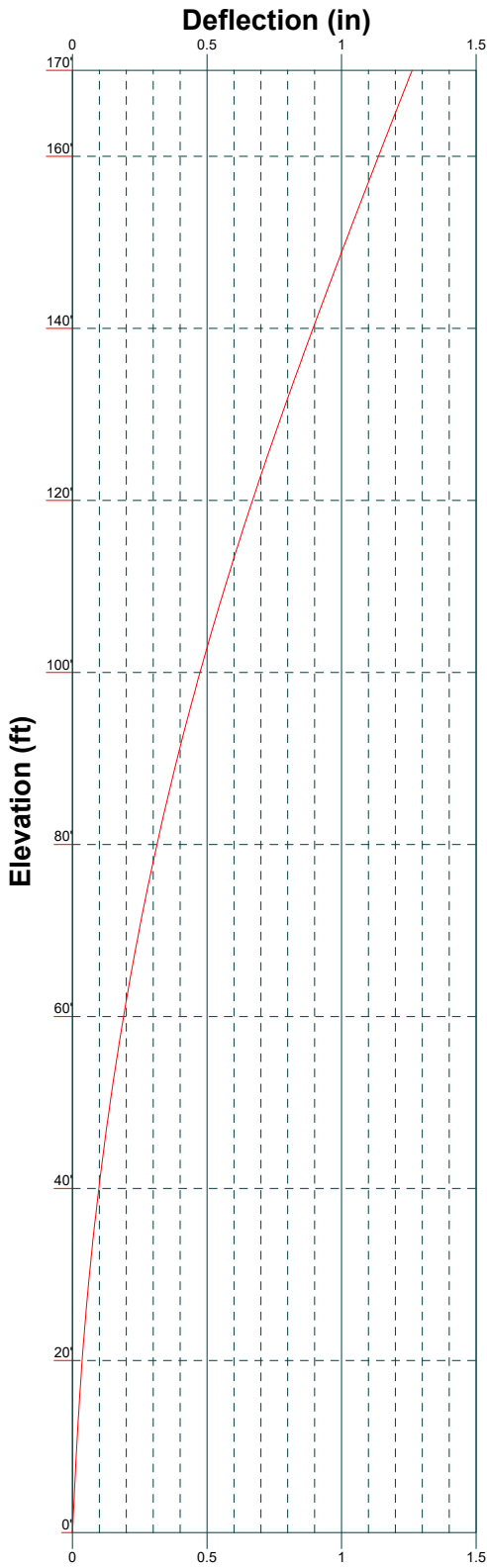

B+T Group
 1717 S, Boulder, Suite 300
 Tulsa, OK 74119
 Phone: (918) 587-4630
 FAX: (918) 587-4630

Job: 100736.010.01.0001 - TRURO, MA (BU# 841273)		
Project:		
Client: Crown Castle	Drawn by: Nithish Acharya	App'd:
Code: TIA-222-H	Date: 09/21/22	Scale: NTS
Path:		Dwg No. E-5

C:\Users\N02006\Desktop\SAISep 21\100736 841273_Trap - Nithish - Siva\Twp 010 01 001\100736 010 01 001 TRURO MA.dwg

Feed Line Distribution Chart

0' - 170'

— Round
 — Flat
 — App In Face
 — App Out Face
 — Truss Leg

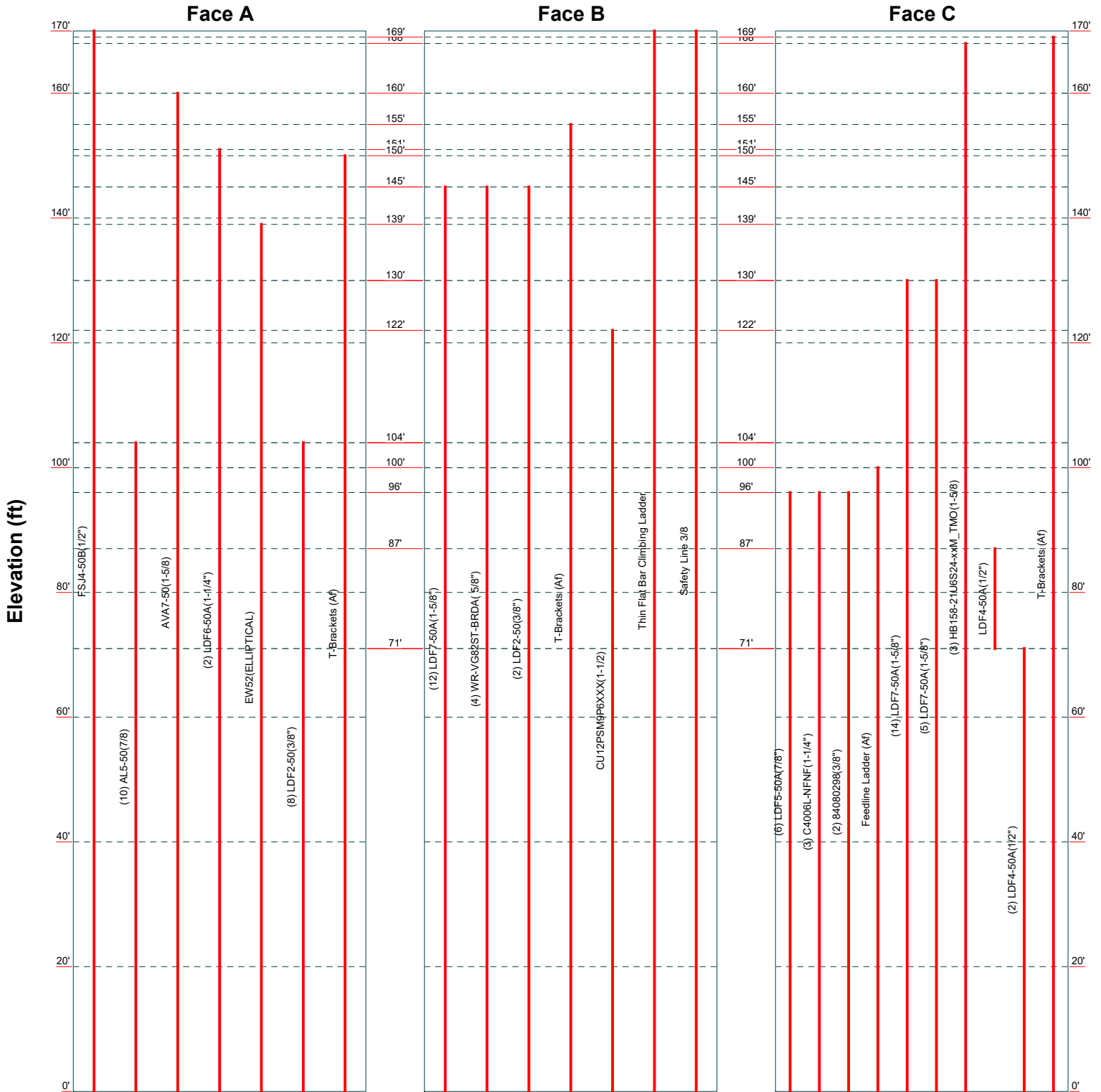

B+T Group
 1717 S, Boulder, Suite 300
 Tulsa, OK 74119
 Phone: (918) 587-4630
 FAX: (918) 587-4630

Job: 100736.010.01.0001 - TRURO, MA (BU# 841273)		
Project:		
Client: Crown Castle	Drawn by: Nithish Acharya	App'd:
Code: TIA-222-H	Date: 09/21/22	Scale: NTS
Path:	Dwg No. E-7	

C:\Users\jhd2006\Desktop\SAISep 21\100736_841273_Truro - Nithish - 5/16/22\100736_010_01_0001_TRURO_M.dwg

<p>tnxTower</p> <p>B+T Group 1717 S, Boulder, Suite 300 Tulsa, OK 74119 Phone: (918) 587-4630 FAX: (918) 587-4630</p>	<p>Job</p> <p>100736.010.01.0001 - TRURO, MA (BU# 841273)</p>	<p>Page</p> <p>1 of 39</p>
	<p>Project</p>	<p>Date</p> <p>14:41:12 09/21/22</p>
	<p>Client</p> <p>Crown Castle</p>	<p>Designed by</p> <p>Nithish Acharya</p>

Tower Input Data

The main tower is a 3x free standing tower with an overall height of 170' above the ground line.

The base of the tower is set at an elevation of 0' above the ground line.

The face width of the tower is 8' at the top and 25' at the base.

This tower is designed using the TIA-222-H standard.

The following design criteria apply:

Tower is located in Barnstable County, Massachusetts.

Tower base elevation above sea level: 107'.

Basic wind speed of 149 mph.

Risk Category III.

Exposure Category C.

Simplified Topographic Factor Procedure for wind speed-up calculations is used.

Topographic Category: 1.

Crest Height: 0'.

Nominal ice thickness of 1.500 in.

Ice thickness is considered to increase with height.

Ice density of 56.000 pcf.

A wind speed of 50 mph is used in combination with ice.

Temperature drop of 50.000 °F.

Deflections calculated using a wind speed of 60 mph.

TIA-222-H Annex S.

Pressures are calculated at each section.

Stress ratio used in tower member design is 1.

Tower analysis based on target reliabilities in accordance with Annex S.

Load Modification Factors used: $K_{es}(F_w) = 1.0$, $K_{es}(t_i) = 1.0$.

Maximum demand-capacity ratio is: 1.05.

Local bending stresses due to climbing loads, feed line supports, and appurtenance mounts are not considered.

Options

Consider Moments - Legs	Distribute Leg Loads As Uniform	Use ASCE 10 X-Brace Ly Rules
Consider Moments - Horizontals	Assume Legs Pinned	√ Calculate Redundant Bracing Forces
Consider Moments - Diagonals	√ Assume Rigid Index Plate	Ignore Redundant Members in FEA
Use Moment Magnification	√ Use Clear Spans For Wind Area	√ SR Leg Bolts Resist Compression
√ Use Code Stress Ratios	√ Use Clear Spans For KL/r	All Leg Panels Have Same Allowable
√ Use Code Safety Factors - Guys	Retension Guys To Initial Tension	Offset Girt At Foundation
Escalate Ice	√ Bypass Mast Stability Checks	√ Consider Feed Line Torque
Always Use Max Kz	√ Use Azimuth Dish Coefficients	√ Include Angle Block Shear Check
Use Special Wind Profile	√ Project Wind Area of Appurt.	Use TIA-222-H Bracing Resist. Exemption
Include Bolts In Member Capacity	Autocalc Torque Arm Areas	Use TIA-222-H Tension Splice Exemption
Leg Bolts Are At Top Of Section	Add IBC .6D+W Combination	Poles
√ Secondary Horizontal Braces Leg	√ Sort Capacity Reports By Component	Include Shear-Torsion Interaction
Use Diamond Inner Bracing (4 Sided)	Triangulate Diamond Inner Bracing	Always Use Sub-Critical Flow
SR Members Have Cut Ends	Treat Feed Line Bundles As Cylinder	Use Top Mounted Sockets
SR Members Are Concentric	Ignore KL/ry For 60 Deg. Angle Legs	Pole Without Linear Attachments
		Pole With Shroud Or No Appurtenances
		Outside and Inside Corner Radii Are
		Known

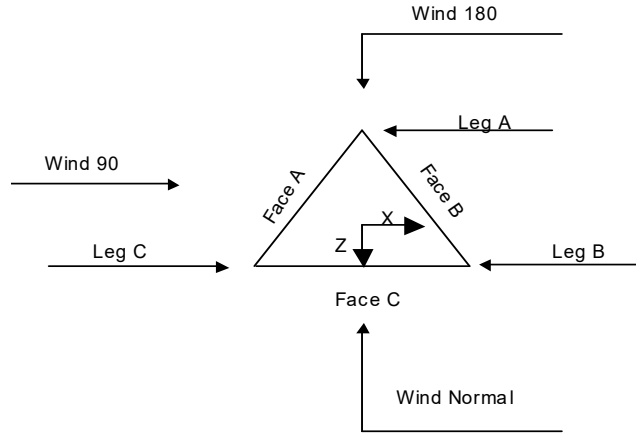

Triangular Tower

Tower Section Geometry

Tower Section	Tower Elevation	Assembly Database	Description	Section Width	Number of Sections	Section Length
	<i>ft</i>			<i>ft</i>		<i>ft</i>
T1	170'-160'			8'	1	10'
T2	160'-140'			9'	1	20'
T3	140'-120'			11'	1	20'
T4	120'-100'			13'	1	20'
T5	100'-80'			15'	1	20'
T6	80'-60'			17'	1	20'
T7	60'-40'			19'	1	20'
T8	40'-20'			21'	1	20'
T9	20'-0'			23'	1	20'

Tower Section Geometry (cont'd)

Tower Section	Tower Elevation	Diagonal Spacing	Bracing Type	Has K Brace End Panels	Has Horizontals	Top Girt Offset	Bottom Girt Offset
	<i>ft</i>	<i>ft</i>				<i>in</i>	<i>in</i>
T1	170'-160'	5'	X Brace	No	No	0.000	0.000
T2	160'-140'	6'8"	X Brace	No	No	0.000	0.000
T3	140'-120'	6'8"	X Brace	No	No	0.000	0.000
T4	120'-100'	6'8"	X Brace	No	No	0.000	0.000

tnxTower B+T Group 1717 S, Boulder, Suite 300 Tulsa, OK 74119 Phone: (918) 587-4630 FAX: (918) 587-4630	Job 100736.010.01.0001 - TRURO, MA (BU# 841273)	Page 3 of 39
	Project	Date 14:41:12 09/21/22
	Client Crown Castle	Designed by Nithish Acharya

Tower Section	Tower Elevation ft	Diagonal Spacing ft	Bracing Type	Has K Brace End Panels	Has Horizontals	Top Girt Offset in	Bottom Girt Offset in
T5	100'-80'	10'	X Brace	No	No	0.000	0.000
T6	80'-60'	10'	X Brace	No	No	0.000	0.000
T7	60'-40'	10'	X Brace	No	No	0.000	0.000
T8	40'-20'	10'	X Brace	No	No	0.000	0.000
T9	20'-0'	10'	K1 Down	No	Yes	0.000	0.000

Tower Section Geometry (cont'd)

Tower Elevation ft	Leg Type	Leg Size	Leg Grade	Diagonal Type	Diagonal Size	Diagonal Grade
T1 170'-160'	Pipe	Sabre 3.5" x 0.216"	A572-50 (50 ksi)	Equal Angle	L2x2x3/8	A36 (36 ksi)
T2 160'-140'	Pipe	Sabre 4.5" x 0.438"	A572-50 (50 ksi)	Equal Angle	L3x3x3/8	A36 (36 ksi)
T3 140'-120'	Pipe	Sabre 6.625" x 0.432"	A572-50 (50 ksi)	Equal Angle	L3 1/2x3 1/2x3/8	A36 (36 ksi)
T4 120'-100'	Pipe	Sabre 8.625" x 0.5"	A572-50 (50 ksi)	Equal Angle	L3 1/2x3 1/2x1/2	A36 (36 ksi)
T5 100'-80'	Pipe	Sabre 10.750" x 0.500"	A572-50 (50 ksi)	Equal Angle	L5x5x1/2	A36 (36 ksi)
T6 80'-60'	Pipe	Sabre 12.75" x 0.5"	A572-50 (50 ksi)	Equal Angle	L5x5x5/8	A36 (36 ksi)
T7 60'-40'	Pipe	Sabre 16" x 0.5"	A572-50 (50 ksi)	Equal Angle	L5x5x5/8	A36 (36 ksi)
T8 40'-20'	Pipe	Sabre 18" x 0.5"	A572-50 (50 ksi)	Equal Angle	L5x5x5/8	A36 (36 ksi)
T9 20'-0'	Pipe	Sabre 18" x 0.5"	A572-50 (50 ksi)	Equal Angle	L5x5x5/8	A36 (36 ksi)

Tower Section Geometry (cont'd)

Tower Elevation ft	Top Girt Type	Top Girt Size	Top Girt Grade	Bottom Girt Type	Bottom Girt Size	Bottom Girt Grade
T1 170'-160'	Equal Angle	L2 1/2x2 1/2x3/16	A36 (36 ksi)	Equal Angle		A36 (36 ksi)

Tower Section Geometry (cont'd)

Tower Elevation ft	No. of Mid Girts	Mid Girt Type	Mid Girt Size	Mid Girt Grade	Horizontal Type	Horizontal Size	Horizontal Grade
T9 20'-0'	None	Flat Bar		A36 (36 ksi)	Double Equal Angle	2L3 1/2x3 1/2x1/4x3/8	A36 (36 ksi)

tnxTower B+T Group 1717 S, Boulder, Suite 300 Tulsa, OK 74119 Phone: (918) 587-4630 FAX: (918) 587-4630	Job 100736.010.01.0001 - TRURO, MA (BU# 841273)	Page 4 of 39
	Project	Date 14:41:12 09/21/22
	Client Crown Castle	Designed by Nithish Acharya

Tower Section Geometry (cont'd)

Tower Elevation	Secondary Horizontal Type	Secondary Horizontal Size	Secondary Horizontal Grade	Inner Bracing Type	Inner Bracing Size	Inner Bracing Grade
ft T9 20'-0'	Equal Angle		A36 (36 ksi)	Equal Angle	L3x3x3/16	A36 (36 ksi)

Tower Section Geometry (cont'd)

Tower Elevation	Redundant Bracing Grade	Redundant Type	Redundant Size	K Factor
ft T9 20'-0'	A36 (36 ksi)	Horizontal (1) Diagonal (1)	Equal Angle Equal Angle	1 1

Tower Section Geometry (cont'd)

Tower Elevation	Gusset Area (per face)	Gusset Thickness	Gusset Grade	Adjust. Factor A_f	Adjust. Factor A_r	Weight Mult.	Double Angle Stitch Bolt Spacing Diagonals	Double Angle Stitch Bolt Spacing Horizontals	Double Angle Stitch Bolt Spacing Redundants
ft	ft ²	in					in	in	in
T1 170'-160'	0.000	0.375	A36 (36 ksi)	1.05	1	1.05	Mid-Pt	Mid-Pt	Mid-Pt
T2 160'-140'	0.000	0.375	A36 (36 ksi)	1.05	1	1.05	Mid-Pt	Mid-Pt	Mid-Pt
T3 140'-120'	0.000	0.375	A36 (36 ksi)	1.05	1	1.05	Mid-Pt	Mid-Pt	Mid-Pt
T4 120'-100'	0.000	0.625	A36 (36 ksi)	1.05	1	1.05	Mid-Pt	Mid-Pt	Mid-Pt
T5 100'-80'	0.000	0.625	A36 (36 ksi)	1.05	1	1.05	Mid-Pt	Mid-Pt	Mid-Pt
T6 80'-60'	0.000	0.625	A36 (36 ksi)	1.05	1	1.05	Mid-Pt	Mid-Pt	Mid-Pt
T7 60'-40'	0.000	0.625	A36 (36 ksi)	1.05	1	1.05	Mid-Pt	Mid-Pt	Mid-Pt
T8 40'-20'	0.000	0.625	A36 (36 ksi)	1.05	1	1.05	Mid-Pt	Mid-Pt	Mid-Pt
T9 20'-0'	0.000	0.625	A36 (36 ksi)	1.05	1	1.05	Mid-Pt	90.450	Mid-Pt

Tower Section Geometry (cont'd)

K Factors¹

Tower Elevation ft	Redundant Horizontal		Redundant Diagonal		Redundant Sub-Diagonal		Redundant Sub-Horizontal		Redundant Vertical		Redundant Hip		Redundant Hip Diagonal	
	Bolt Size in	No.	Bolt Size in	No.	Bolt Size in	No.	Bolt Size in	No.	Bolt Size in	No.	Bolt Size in	No.	Bolt Size in	No.
T6 80'-60'	0.625 A325N	0	0.625 A325N	0	0.625 A325N	0	0.625 A325N	0	0.625 A325N	0	0.625 A325N	0	0.625 A325N	0
T7 60'-40'	0.625 A325N	0	0.625 A325N	0	0.625 A325N	0	0.625 A325N	0	0.625 A325N	0	0.625 A325N	0	0.625 A325N	0
T8 40'-20'	0.625 A325N	0	0.625 A325N	0	0.625 A325N	0	0.625 A325N	0	0.625 A325N	0	0.625 A325N	0	0.625 A325N	0
T9 20'-0'	1.000 A325N	1	1.000 A325N	1	0.625 A325N	0	0.625 A325N	0	0.625 A325N	0	0.625 A325N	0	0.625 A325N	0

Feed Line/Linear Appurtenances - Entered As Round Or Flat

Description	Face or Leg	Allow Shield	Exclude From Torque Calculation	Component Type	Placement ft	Face Offset in	Lateral Offset (Frac FW)	#	# Per Row	Clear Spacing in	Width or Diameter in	Perimeter in	Weight klf
FSJ4-50B(1/2") *)	A	No	No	Ar (CaAa)	170' - 0'	-6.000	0.4	1	1	0.850 0.750	0.520		0.000
AL5-50(7/8) *)	A	No	No	Ar (CaAa)	104' - 0'	-8.000	0.44	10	10	0.850 0.750	1.100		0.000
AVA7-50(1-5/8) *)	A	No	No	Ar (CaAa)	160' - 0'	-6.000	0.46	1	1	0.850 0.750	2.010		0.001
LDF6-50A(1-1/4") *)	A	No	No	Ar (CaAa)	151' - 0'	-9.000	0.4	2	1	0.850 0.750	1.550		0.001
EW52(ELLIP TICAL) *)	A	No	No	Ar (CaAa)	139' - 0'	-12.000	0.4	1	1	0.850 0.750	2.250		0.001
LDF2-50(3/8") T-Brackets (Af) *)	A	No	No	Ar (CaAa)	104' - 0'	-6.500	0.43	8	8	0.400	0.440		0.000
	A	No	No	Af (CaAa)	150' - 0'	-6.000	0.45	1	1	1.000	1.000		0.008
LDF7-50A(1-5/8") WR-VG82ST-BRDA(5/8") LDF2-50(3/8") T-Brackets (Af) *)	B	No	No	Ar (CaAa)	145' - 0'	-16.000	0.4	12	2	0.850 0.750	1.980		0.001
	B	No	No	Ar (CaAa)	145' - 0'	-13.000	0.39	4	1	0.750	0.645		0.000
	B	No	No	Ar (CaAa)	145' - 0'	-11.000	0.39	2	1	0.750	0.440		0.000
	B	No	No	Af (CaAa)	155' - 0'	-7.000	0.43	1	1	1.000	1.000		0.008
CU12PSM9P6 XXX(1-1/2) *)	B	No	No	Ar (CaAa)	122' - 0'	-16.000	0.42	1	1	0.850 0.750	1.600		0.002
LDF5-50A(7/8") C4006L-NFN F(1-1/4") 84080298(3/8")) Feedline Ladder (Af) *)	C	No	No	Ar (CaAa)	96' - 0'	0.000	-0.03	6	6	0.850 0.750	1.090		0.000
	C	No	No	Ar (CaAa)	96' - 0'	0.000	0.01	3	3	0.850 0.750	1.280		0.001
	C	No	No	Ar (CaAa)	96' - 0'	0.000	0.03	2	2	0.500	0.276		0.000
	C	No	No	Af (CaAa)	100' - 0'	0.000	0	1	1	3.000	3.000		0.008

tnxTower B+T Group 1717 S, Boulder, Suite 300 Tulsa, OK 74119 Phone: (918) 587-4630 FAX: (918) 587-4630	Job 100736.010.01.0001 - TRURO, MA (BU# 841273)	Page 8 of 39
	Project	Date 14:41:12 09/21/22
	Client Crown Castle	Designed by Nithish Acharya

Description	Face or Leg	Allow Shield	Exclude From Torque Calculation	Component Type	Placement ft	Face Offset in	Lateral Offset (Frac FW)	#	# Per Row	Clear Spacing in	Width or Diameter in	Perimeter in	Weight klf
LDF7-50A(1-5/8")	C	No	No	Ar (CaAa)	130' - 0'	-16.000	0.42	14	8	0.500	1.980		0.001
LDF7-50A(1-5/8")	C	No	No	Ar (CaAa)	130' - 0'	-11.000	0.42	5	2	0.500	1.980		0.001
* HB158-21U6S 24-xxM TMO (1-5/8")	C	No	No	Ar (CaAa)	168' - 0'	-11.000	0.42	3	3	0.850 0.750	1.996		0.003
* LDF4-50A(1/2")	C	No	No	Ar (CaAa)	87' - 71'	-5.000	0.43	1	1	0.500	0.630		0.000
LDF4-50A(1/2")	C	No	No	Ar (CaAa)	71' - 0'	-5.000	0.43	2	1	0.500	0.630		0.000
* T-Brackets (Af)	C	No	No	Af (CaAa)	169' - 0'	-7.000	0.43	1	1	1.000	1.000		0.008
* Thin Flat Bar Climbing Ladder	B	No	No	Af (CaAa)	170' - 0'	0.000	0	1	1	2.000	2.000		0.004
* Safety Line 3/8"	B	No	No	Ar (CaAa)	170' - 0'	1.000	0.01	1	1	0.375	0.375		0.000
* *													
* *													

Feed Line/Linear Appurtenances - Entered As Area

Description	Face or Leg	Allow Shield	Exclude From Torque Calculation	Component Type	Placement ft	Total Number	C _{AA} ft ² /ft	Weight klf
* *								
* *								

Feed Line/Linear Appurtenances Section Areas

Tower Section	Tower Elevation ft	Face	A _R ft ²	A _F ft ²	C _{AA} In Face ft ²	C _{AA} Out Face ft ²	Weight K
T1	170'-160'	A	0.000	0.000	0.520	0.000	0.001
		B	0.000	0.000	3.708	0.000	0.042
		C	0.000	0.000	6.290	0.000	0.136
T2	160'-140'	A	0.000	0.000	10.137	0.000	0.115
		B	0.000	0.000	23.527	0.000	0.267
		C	0.000	0.000	15.309	0.000	0.318
T3	140'-120'	A	0.000	0.000	18.868	0.000	0.222
		B	0.000	0.000	65.510	0.000	0.482
		C	0.000	0.000	52.929	0.000	0.474
T4	120'-100'	A	0.000	0.000	24.901	0.000	0.236

<p>tnxTower</p> <p>B+T Group 1717 S, Boulder, Suite 300 Tulsa, OK 74119 Phone: (918) 587-4630 FAX: (918) 587-4630</p>	<p>Job</p> <p>100736.010.01.0001 - TRURO, MA (BU# 841273)</p>	<p>Page</p> <p>9 of 39</p>
	<p>Project</p>	<p>Date</p> <p>14:41:12 09/21/22</p>
	<p>Client</p> <p>Crown Castle</p>	<p>Designed by</p> <p>Nithish Acharya</p>

Tower Section	Tower Elevation ft	Face	A _R ft ²	A _F ft ²	C _A A _A In Face ft ²	C _A A _A Out Face ft ²	Weight K
T5	100'-80'	B	0.000	0.000	68.390	0.000	0.524
		C	0.000	0.000	90.549	0.000	0.630
		A	0.000	0.000	48.133	0.000	0.288
T6	80'-60'	B	0.000	0.000	68.390	0.000	0.524
		C	0.000	0.000	118.480	0.000	0.858
		A	0.000	0.000	48.133	0.000	0.288
T7	60'-40'	B	0.000	0.000	68.390	0.000	0.524
		C	0.000	0.000	124.364	0.000	0.877
		A	0.000	0.000	48.133	0.000	0.288
T8	40'-20'	B	0.000	0.000	68.390	0.000	0.524
		C	0.000	0.000	124.931	0.000	0.878
		A	0.000	0.000	48.133	0.000	0.288
T9	20'-0'	B	0.000	0.000	68.390	0.000	0.524
		C	0.000	0.000	124.931	0.000	0.878
		A	0.000	0.000	48.133	0.000	0.288

Feed Line/Linear Appurtenances Section Areas - With Ice

Tower Section	Tower Elevation ft	Face or Leg	Ice Thickness in	A _R ft ²	A _F ft ²	C _A A _A In Face ft ²	C _A A _A Out Face ft ²	Weight K
T1	170'-160'	A	2.026	0.000	0.000	4.572	0.000	0.064
		B		0.000	0.000	11.813	0.000	0.225
		C		0.000	0.000	18.354	0.000	0.386
T2	160'-140'	A	2.007	0.000	0.000	40.042	0.000	0.719
		B		0.000	0.000	56.194	0.000	1.203
		C		0.000	0.000	44.249	0.000	0.913
T3	140'-120'	A	1.978	0.000	0.000	67.813	0.000	1.248
		B		0.000	0.000	131.824	0.000	2.758
		C		0.000	0.000	92.118	0.000	1.804
T4	120'-100'	A	1.946	0.000	0.000	84.771	0.000	1.458
		B		0.000	0.000	140.634	0.000	2.903
		C		0.000	0.000	139.502	0.000	2.671
T5	100'-80'	A	1.907	0.000	0.000	151.758	0.000	2.306
		B		0.000	0.000	139.229	0.000	2.841
		C		0.000	0.000	224.133	0.000	3.903
T6	80'-60'	A	1.860	0.000	0.000	150.081	0.000	2.240
		B		0.000	0.000	137.509	0.000	2.766
		C		0.000	0.000	248.478	0.000	4.148
T7	60'-40'	A	1.798	0.000	0.000	147.901	0.000	2.157
		B		0.000	0.000	135.273	0.000	2.671
		C		0.000	0.000	249.035	0.000	4.076
T8	40'-20'	A	1.709	0.000	0.000	144.734	0.000	2.038
		B		0.000	0.000	132.023	0.000	2.536
		C		0.000	0.000	244.094	0.000	3.898
T9	20'-0'	A	1.531	0.000	0.000	138.462	0.000	1.811
		B		0.000	0.000	125.581	0.000	2.281
		C		0.000	0.000	234.306	0.000	3.558

Feed Line Center of Pressure

tnxTower B+T Group 1717 S, Boulder, Suite 300 Tulsa, OK 74119 Phone: (918) 587-4630 FAX: (918) 587-4630	Job 100736.010.01.0001 - TRURO, MA (BU# 841273)	Page 10 of 39
	Project	Date 14:41:12 09/21/22
	Client Crown Castle	Designed by Nithish Acharya

Section	Elevation	CP _x	CP _z	CP _x	CP _z
	ft	in	in	Ice in	Ice in
T1	170'-160'	-2.958	-0.142	-3.401	-1.493
T2	160'-140'	0.270	-1.667	0.264	-4.129
T3	140'-120'	-0.577	1.572	1.863	-1.702
T4	120'-100'	-6.122	1.875	-1.719	-1.582
T5	100'-80'	-5.591	-2.833	-1.798	-5.243
T6	80'-60'	-5.994	-2.445	-2.721	-4.169
T7	60'-40'	-6.210	-2.388	-3.026	-4.238
T8	40'-20'	-6.443	-2.457	-3.258	-4.570
T9	20'-0'	-6.334	-2.406	-3.417	-4.751

Shielding Factor Ka

Tower Section	Feed Line Record No.	Description	Feed Line Segment Elev.	K _a No Ice	K _a Ice
T1	1	FSJ4-50B(1/2")	160.00 - 170.00	0.6000	0.6000
T1	32	HB158-21U6S24-xxM_TMO (1-5/8)	160.00 - 168.00	0.6000	0.6000
T1	36	T-Brackets (Af)	160.00 - 169.00	0.6000	0.6000
T1	38	Thin Flat Bar Climbing Ladder	160.00 - 170.00	0.6000	0.6000
T1	39	Safety Line 3/8	160.00 - 170.00	0.6000	0.6000
T2	1	FSJ4-50B(1/2")	140.00 - 160.00	0.6000	0.6000
T2	6	AVA7-50(1-5/8)	140.00 - 160.00	0.6000	0.6000
T2	8	LDF6-50A(1-1/4")	140.00 - 151.00	0.6000	0.6000
T2	13	T-Brackets (Af)	140.00 - 150.00	0.6000	0.6000
T2	15	LDF7-50A(1-5/8")	140.00 - 145.00	0.6000	0.6000
T2	16	WR-VG82ST-BRDA(5/8")	140.00 - 145.00	0.6000	0.6000
T2	18	LDF2-50(3/8")	140.00 - 145.00	0.6000	0.6000
T2	19	T-Brackets (Af)	140.00 - 155.00	0.6000	0.6000
T2	32	HB158-21U6S24-xxM_TMO (1-5/8)	140.00 - 160.00	0.6000	0.6000
T2	36	T-Brackets (Af)	140.00 - 160.00	0.6000	0.6000
T2	38	Thin Flat Bar Climbing Ladder	140.00 - 160.00	0.6000	0.6000
T2	39	Safety Line 3/8	140.00 - 160.00	0.6000	0.6000
T3	1	FSJ4-50B(1/2")	120.00 - 140.00	0.6000	0.6000
T3	6	AVA7-50(1-5/8)	120.00 - 140.00	0.6000	0.6000
T3	8	LDF6-50A(1-1/4")	120.00 - 140.00	0.6000	0.6000
T3	10	EW52(ELLIPTICAL)	120.00 -	0.6000	0.6000

tnxTower

B+T Group
 1717 S, Boulder, Suite 300
 Tulsa, OK 74119
 Phone: (918) 587-4630
 FAX: (918) 587-4630

Job
 100736.010.01.0001 - TRURO, MA (BU# 841273)

Page
 11 of 39

Project
 Date
 14:41:12 09/21/22

Client
 Crown Castle
 Designed by
 Nithish Acharya

Tower Section	Feed Line Record No.	Description	Feed Line Segment Elev.	K_a No Ice	K_a Ice
			139.00		
T3	13	T-Brackets (Af)	120.00 - 140.00	0.6000	0.6000
T3	15	LDF7-50A(1-5/8")	120.00 - 140.00	0.6000	0.6000
T3	16	WR-VG82ST-BRDA(5/8")	120.00 - 140.00	0.6000	0.6000
T3	18	LDF2-50(3/8")	120.00 - 140.00	0.6000	0.6000
T3	19	T-Brackets (Af)	120.00 - 140.00	0.6000	0.6000
T3	21	CU12PSM9P6XXX(1-1/2)	120.00 - 122.00	0.6000	0.6000
T3	28	LDF7-50A(1-5/8")	120.00 - 130.00	0.6000	0.6000
T3	29	LDF7-50A(1-5/8")	120.00 - 130.00	0.6000	0.6000
T3	32	HB158-21U6S24-xxM_TMO (1-5/8)	120.00 - 140.00	0.6000	0.6000
T3	36	T-Brackets (Af)	120.00 - 140.00	0.6000	0.6000
T3	38	Thin Flat Bar Climbing Ladder	120.00 - 140.00	0.6000	0.6000
T3	39	Safety Line 3/8	120.00 - 140.00	0.6000	0.6000
T4	1	FSJ4-50B(1/2")	100.00 - 120.00	0.6000	0.6000
T4	4	AL5-50(7/8)	100.00 - 104.00	0.6000	0.6000
T4	6	AVA7-50(1-5/8)	100.00 - 120.00	0.6000	0.6000
T4	8	LDF6-50A(1-1/4")	100.00 - 120.00	0.6000	0.6000
T4	10	EW52(ELLIPTICAL)	100.00 - 120.00	0.6000	0.6000
T4	12	LDF2-50(3/8")	100.00 - 104.00	0.6000	0.6000
T4	13	T-Brackets (Af)	100.00 - 120.00	0.6000	0.6000
T4	15	LDF7-50A(1-5/8")	100.00 - 120.00	0.6000	0.6000
T4	16	WR-VG82ST-BRDA(5/8")	100.00 - 120.00	0.6000	0.6000
T4	18	LDF2-50(3/8")	100.00 - 120.00	0.6000	0.6000
T4	19	T-Brackets (Af)	100.00 - 120.00	0.6000	0.6000
T4	21	CU12PSM9P6XXX(1-1/2)	100.00 - 120.00	0.6000	0.6000
T4	28	LDF7-50A(1-5/8")	100.00 - 120.00	0.6000	0.6000
T4	29	LDF7-50A(1-5/8")	100.00 - 120.00	0.6000	0.6000
T4	32	HB158-21U6S24-xxM_TMO (1-5/8)	100.00 - 120.00	0.6000	0.6000
T4	36	T-Brackets (Af)	100.00 - 120.00	0.6000	0.6000
T4	38	Thin Flat Bar Climbing Ladder	100.00 - 120.00	0.6000	0.6000
T4	39	Safety Line 3/8	100.00 - 120.00	0.6000	0.6000
T5	1	FSJ4-50B(1/2")	80.00 - 100.00	0.6000	0.6000

tnxTower

B+T Group
1717 S, Boulder, Suite 300
Tulsa, OK 74119
Phone: (918) 587-4630
FAX: (918) 587-4630

Job 100736.010.01.0001 - TRURO, MA (BU# 841273)	Page 12 of 39
Project	Date 14:41:12 09/21/22
Client Crown Castle	Designed by Nithish Acharya

Tower Section	Feed Line Record No.	Description	Feed Line Segment Elev.	K_a No Ice	K_a Ice
T5	4	AL5-50(7/8)	80.00 - 100.00	0.6000	0.6000
T5	6	AVA7-50(1-5/8)	80.00 - 100.00	0.6000	0.6000
T5	8	LDF6-50A(1-1/4")	80.00 - 100.00	0.6000	0.6000
T5	10	EW52(ELLIPTICAL)	80.00 - 100.00	0.6000	0.6000
T5	12	LDF2-50(3/8")	80.00 - 100.00	0.6000	0.6000
T5	13	T-Brackets (Af)	80.00 - 100.00	0.6000	0.6000
T5	15	LDF7-50A(1-5/8")	80.00 - 100.00	0.6000	0.6000
T5	16	WR-VG82ST-BRDA(5/8")	80.00 - 100.00	0.6000	0.6000
T5	18	LDF2-50(3/8")	80.00 - 100.00	0.6000	0.6000
T5	19	T-Brackets (Af)	80.00 - 100.00	0.6000	0.6000
T5	21	CU12PSM9P6XXX(1-1/2)	80.00 - 100.00	0.6000	0.6000
T5	23	LDF5-50A(7/8")	80.00 - 96.00	0.6000	0.6000
T5	24	C4006L-NFNF(1-1/4")	80.00 - 96.00	0.6000	0.6000
T5	25	84080298(3/8")	80.00 - 96.00	0.6000	0.6000
T5	26	Feedline Ladder (Af)	80.00 - 100.00	0.6000	0.6000
T5	28	LDF7-50A(1-5/8")	80.00 - 100.00	0.6000	0.6000
T5	29	LDF7-50A(1-5/8")	80.00 - 100.00	0.6000	0.6000
T5	32	HB158-21U6S24-xxM_TMO (1-5/8)	80.00 - 100.00	0.6000	0.6000
T5	34	LDF4-50A(1/2")	80.00 - 87.00	0.6000	0.6000
T5	36	T-Brackets (Af)	80.00 - 100.00	0.6000	0.6000
T5	38	Thin Flat Bar Climbing Ladder	80.00 - 100.00	0.6000	0.6000
T5	39	Safety Line 3/8	80.00 - 100.00	0.6000	0.6000
T6	1	FSJ4-50B(1/2")	60.00 - 80.00	0.6000	0.6000
T6	4	AL5-50(7/8)	60.00 - 80.00	0.6000	0.6000
T6	6	AVA7-50(1-5/8)	60.00 - 80.00	0.6000	0.6000
T6	8	LDF6-50A(1-1/4")	60.00 - 80.00	0.6000	0.6000
T6	10	EW52(ELLIPTICAL)	60.00 - 80.00	0.6000	0.6000
T6	12	LDF2-50(3/8")	60.00 - 80.00	0.6000	0.6000
T6	13	T-Brackets (Af)	60.00 - 80.00	0.6000	0.6000
T6	15	LDF7-50A(1-5/8")	60.00 - 80.00	0.6000	0.6000
T6	16	WR-VG82ST-BRDA(5/8")	60.00 - 80.00	0.6000	0.6000
T6	18	LDF2-50(3/8")	60.00 - 80.00	0.6000	0.6000
T6	19	T-Brackets (Af)	60.00 - 80.00	0.6000	0.6000
T6	21	CU12PSM9P6XXX(1-1/2)	60.00 - 80.00	0.6000	0.6000
T6	23	LDF5-50A(7/8")	60.00 - 80.00	0.6000	0.6000
T6	24	C4006L-NFNF(1-1/4")	60.00 - 80.00	0.6000	0.6000
T6	25	84080298(3/8")	60.00 - 80.00	0.6000	0.6000
T6	26	Feedline Ladder (Af)	60.00 - 80.00	0.6000	0.6000
T6	28	LDF7-50A(1-5/8")	60.00 - 80.00	0.6000	0.6000
T6	29	LDF7-50A(1-5/8")	60.00 - 80.00	0.6000	0.6000
T6	32	HB158-21U6S24-xxM_TMO (1-5/8)	60.00 - 80.00	0.6000	0.6000
T6	34	LDF4-50A(1/2")	71.00 - 80.00	0.6000	0.6000
T6	35	LDF4-50A(1/2")	60.00 - 71.00	0.6000	0.6000
T6	36	T-Brackets (Af)	60.00 - 80.00	0.6000	0.6000
T6	38	Thin Flat Bar Climbing Ladder	60.00 - 80.00	0.6000	0.6000
T6	39	Safety Line 3/8	60.00 - 80.00	0.6000	0.6000
T7	1	FSJ4-50B(1/2")	40.00 - 60.00	0.6000	0.6000
T7	4	AL5-50(7/8)	40.00 - 60.00	0.6000	0.6000
T7	6	AVA7-50(1-5/8)	40.00 - 60.00	0.6000	0.6000
T7	8	LDF6-50A(1-1/4")	40.00 - 60.00	0.6000	0.6000
T7	10	EW52(ELLIPTICAL)	40.00 - 60.00	0.6000	0.6000
T7	12	LDF2-50(3/8")	40.00 - 60.00	0.6000	0.6000
T7	13	T-Brackets (Af)	40.00 - 60.00	0.6000	0.6000
T7	15	LDF7-50A(1-5/8")	40.00 - 60.00	0.6000	0.6000
T7	16	WR-VG82ST-BRDA(5/8")	40.00 - 60.00	0.6000	0.6000
T7	18	LDF2-50(3/8")	40.00 - 60.00	0.6000	0.6000
T7	19	T-Brackets (Af)	40.00 - 60.00	0.6000	0.6000
T7	21	CU12PSM9P6XXX(1-1/2)	40.00 - 60.00	0.6000	0.6000

Tower Section	Feed Line Record No.	Description	Feed Line Segment Elev.	K_a No Ice	K_a Ice
T7	23	LDF5-50A(7/8")	40.00 - 60.00	0.6000	0.6000
T7	24	C4006L-NFNF(1-1/4")	40.00 - 60.00	0.6000	0.6000
T7	25	84080298(3/8")	40.00 - 60.00	0.6000	0.6000
T7	26	Feedline Ladder (Af)	40.00 - 60.00	0.6000	0.6000
T7	28	LDF7-50A(1-5/8")	40.00 - 60.00	0.6000	0.6000
T7	29	LDF7-50A(1-5/8")	40.00 - 60.00	0.6000	0.6000
T7	32	HB158-21U6S24-xxM_TMO (1-5/8)	40.00 - 60.00	0.6000	0.6000
T7	35	LDF4-50A(1/2")	40.00 - 60.00	0.6000	0.6000
T7	36	T-Brackets (Af)	40.00 - 60.00	0.6000	0.6000
T7	38	Thin Flat Bar Climbing Ladder	40.00 - 60.00	0.6000	0.6000
T7	39	Safety Line 3/8	40.00 - 60.00	0.6000	0.6000
T8	1	FSJ4-50B(1/2")	20.00 - 40.00	0.6000	0.6000
T8	4	AL5-50(7/8)	20.00 - 40.00	0.6000	0.6000
T8	6	AVA7-50(1-5/8)	20.00 - 40.00	0.6000	0.6000
T8	8	LDF6-50A(1-1/4")	20.00 - 40.00	0.6000	0.6000
T8	10	EW52(ELLIPTICAL)	20.00 - 40.00	0.6000	0.6000
T8	12	LDF2-50(3/8")	20.00 - 40.00	0.6000	0.6000
T8	13	T-Brackets (Af)	20.00 - 40.00	0.6000	0.6000
T8	15	LDF7-50A(1-5/8")	20.00 - 40.00	0.6000	0.6000
T8	16	WR-VG82ST-BRDA(5/8")	20.00 - 40.00	0.6000	0.6000
T8	18	LDF2-50(3/8")	20.00 - 40.00	0.6000	0.6000
T8	19	T-Brackets (Af)	20.00 - 40.00	0.6000	0.6000
T8	21	CU12PSM9P6XXX(1-1/2)	20.00 - 40.00	0.6000	0.6000
T8	23	LDF5-50A(7/8")	20.00 - 40.00	0.6000	0.6000
T8	24	C4006L-NFNF(1-1/4")	20.00 - 40.00	0.6000	0.6000
T8	25	84080298(3/8")	20.00 - 40.00	0.6000	0.6000
T8	26	Feedline Ladder (Af)	20.00 - 40.00	0.6000	0.6000
T8	28	LDF7-50A(1-5/8")	20.00 - 40.00	0.6000	0.6000
T8	29	LDF7-50A(1-5/8")	20.00 - 40.00	0.6000	0.6000
T8	32	HB158-21U6S24-xxM_TMO (1-5/8)	20.00 - 40.00	0.6000	0.6000
T8	35	LDF4-50A(1/2")	20.00 - 40.00	0.6000	0.6000
T8	36	T-Brackets (Af)	20.00 - 40.00	0.6000	0.6000
T8	38	Thin Flat Bar Climbing Ladder	20.00 - 40.00	0.6000	0.6000
T8	39	Safety Line 3/8	20.00 - 40.00	0.6000	0.6000
T9	1	FSJ4-50B(1/2")	0.00 - 20.00	0.6000	0.6000
T9	4	AL5-50(7/8)	0.00 - 20.00	0.6000	0.6000
T9	6	AVA7-50(1-5/8)	0.00 - 20.00	0.6000	0.6000
T9	8	LDF6-50A(1-1/4")	0.00 - 20.00	0.6000	0.6000
T9	10	EW52(ELLIPTICAL)	0.00 - 20.00	0.6000	0.6000
T9	12	LDF2-50(3/8")	0.00 - 20.00	0.6000	0.6000
T9	13	T-Brackets (Af)	0.00 - 20.00	0.6000	0.6000
T9	15	LDF7-50A(1-5/8")	0.00 - 20.00	0.6000	0.6000
T9	16	WR-VG82ST-BRDA(5/8")	0.00 - 20.00	0.6000	0.6000
T9	18	LDF2-50(3/8")	0.00 - 20.00	0.6000	0.6000
T9	19	T-Brackets (Af)	0.00 - 20.00	0.6000	0.6000
T9	21	CU12PSM9P6XXX(1-1/2)	0.00 - 20.00	0.6000	0.6000
T9	23	LDF5-50A(7/8")	0.00 - 20.00	0.6000	0.6000
T9	24	C4006L-NFNF(1-1/4")	0.00 - 20.00	0.6000	0.6000
T9	25	84080298(3/8")	0.00 - 20.00	0.6000	0.6000
T9	26	Feedline Ladder (Af)	0.00 - 20.00	0.6000	0.6000
T9	28	LDF7-50A(1-5/8")	0.00 - 20.00	0.6000	0.6000
T9	29	LDF7-50A(1-5/8")	0.00 - 20.00	0.6000	0.6000
T9	32	HB158-21U6S24-xxM_TMO (1-5/8)	0.00 - 20.00	0.6000	0.6000
T9	35	LDF4-50A(1/2")	0.00 - 20.00	0.6000	0.6000
T9	36	T-Brackets (Af)	0.00 - 20.00	0.6000	0.6000
T9	38	Thin Flat Bar Climbing Ladder	0.00 - 20.00	0.6000	0.6000

tnxTower B+T Group 1717 S, Boulder, Suite 300 Tulsa, OK 74119 Phone: (918) 587-4630 FAX: (918) 587-4630	Job 100736.010.01.0001 - TRURO, MA (BU# 841273)	Page 14 of 39
	Project	Date 14:41:12 09/21/22
	Client Crown Castle	Designed by Nithish Acharya

Tower Section	Feed Line Record No.	Description	Feed Line Segment Elev.	K _a No Ice	K _a Ice
T9	39	Safety Line 3/8	0.00 - 20.00	0.6000	0.6000

Discrete Tower Loads

Description	Face or Leg	Offset Type	Offsets:			Azimuth Adjustment	Placement	C _A A _{Front}	C _A A _{Side}	Weight
			Horz	Vert	Lateral					
Lightning Rod 5/8" x 5'	A	From Leg	0.000	0.000	170'	No Ice	0.313	0.313	0.006	
			0'			1/2" Ice	0.826	0.826	0.010	
			2'6"			1" Ice	1.322	1.322	0.016	
						2" Ice	1.957	1.957	0.040	
* DB806-XC	C	From Leg	0.000	0.000	170'	No Ice	1.140	1.140	0.021	
			0'			1/2" Ice	1.675	1.675	0.030	
			4'			1" Ice	2.025	2.025	0.043	
						2" Ice	2.753	2.753	0.080	
8' x 2.375" Mount Pipe	C	From Leg	0.000	0.000	170'	No Ice	1.900	1.900	0.029	
			0'			1/2" Ice	2.728	2.728	0.044	
			0'			1" Ice	3.401	3.401	0.063	
						2" Ice	4.396	4.396	0.119	
* AIR 6419 B41_TMO	A	From Leg	4.000	0.000	168'	No Ice	6.998	2.830	0.097	
			0'			1/2" Ice	7.527	3.243	0.140	
			1'			1" Ice	8.073	3.675	0.188	
						2" Ice	9.219	4.591	0.298	
AIR 6419 B41_TMO	B	From Leg	4.000	0.000	168'	No Ice	6.998	2.830	0.097	
			0'			1/2" Ice	7.527	3.243	0.140	
			1'			1" Ice	8.073	3.675	0.188	
						2" Ice	9.219	4.591	0.298	
AIR 6419 B41_TMO	C	From Leg	4.000	0.000	168'	No Ice	6.998	2.830	0.097	
			0'			1/2" Ice	7.527	3.243	0.140	
			1'			1" Ice	8.073	3.675	0.188	
						2" Ice	9.219	4.591	0.298	
4003_840590966_TMO	A	From Leg	4.000	0.000	168'	No Ice	10.237	3.117	0.136	
			0'			1/2" Ice	10.781	3.587	0.240	
			1'			1" Ice	11.334	4.066	0.353	
						2" Ice	12.468	5.051	0.605	
4003_840590966_TMO	B	From Leg	4.000	0.000	168'	No Ice	10.237	3.117	0.136	
			0'			1/2" Ice	10.781	3.587	0.240	
			1'			1" Ice	11.334	4.066	0.353	
						2" Ice	12.468	5.051	0.605	
4003_840590966_TMO	C	From Leg	4.000	0.000	168'	No Ice	10.237	3.117	0.136	
			0'			1/2" Ice	10.781	3.587	0.240	
			1'			1" Ice	11.334	4.066	0.353	
						2" Ice	12.468	5.051	0.605	
APXVLL19P_43-C-A20_TM O	A	From Leg	4.000	0.000	168'	No Ice	5.154	2.110	0.048	
			0'			1/2" Ice	5.681	2.597	0.092	
			1'			1" Ice	6.220	3.096	0.142	
						2" Ice	7.334	4.130	0.261	
APXVLL19P_43-C-A20_TM	B	From Leg	4.000	0.000	168'	No Ice	5.154	2.110	0.048	

tnxTower B+T Group 1717 S, Boulder, Suite 300 Tulsa, OK 74119 Phone: (918) 587-4630 FAX: (918) 587-4630	Job		100736.010.01.0001 - TRURO, MA (BU# 841273)		Page		15 of 39	
	Project				Date		14:41:12 09/21/22	
	Client		Crown Castle		Designed by		Nithish Acharya	

Description	Face or Leg	Offset Type	Offsets:		Azimuth Adjustment	Placement	C _{AA} Front	C _{AA} Side	Weight
			Horz	Lateral					
				0'					
				1'		1/2" Ice	5.681	2.597	0.092
						1" Ice	6.220	3.096	0.142
						2" Ice	7.334	4.130	0.261
APXVLL19P_43-C-A20_TM	C	From Leg	4.000	0.000	168'	No Ice	5.154	2.110	0.048
O			0'			1/2" Ice	5.681	2.597	0.092
			1'			1" Ice	6.220	3.096	0.142
						2" Ice	7.334	4.130	0.261
RADIO 4460 B2/B25 B66_TMO	A	From Leg	4.000	0.000	168'	No Ice	2.139	1.686	0.109
			0'			1/2" Ice	2.321	1.850	0.131
			1'			1" Ice	2.511	2.022	0.156
						2" Ice	2.912	2.387	0.217
RADIO 4460 B2/B25 B66_TMO	B	From Leg	4.000	0.000	168'	No Ice	2.139	1.686	0.109
			0'			1/2" Ice	2.321	1.850	0.131
			1'			1" Ice	2.511	2.022	0.156
						2" Ice	2.912	2.387	0.217
RADIO 4460 B2/B25 B66_TMO	C	From Leg	4.000	0.000	168'	No Ice	2.139	1.686	0.109
			0'			1/2" Ice	2.321	1.850	0.131
			1'			1" Ice	2.511	2.022	0.156
						2" Ice	2.912	2.387	0.217
Radio 4480_TMOV2	A	From Leg	4.000	0.000	168'	No Ice	2.878	1.397	0.081
			0'			1/2" Ice	3.091	1.558	0.103
			1'			1" Ice	3.312	1.727	0.128
						2" Ice	3.775	2.090	0.188
Radio 4480_TMOV2	B	From Leg	4.000	0.000	168'	No Ice	2.878	1.397	0.081
			0'			1/2" Ice	3.091	1.558	0.103
			1'			1" Ice	3.312	1.727	0.128
						2" Ice	3.775	2.090	0.188
Radio 4480_TMOV2	C	From Leg	4.000	0.000	168'	No Ice	2.878	1.397	0.081
			0'			1/2" Ice	3.091	1.558	0.103
			1'			1" Ice	3.312	1.727	0.128
						2" Ice	3.775	2.090	0.188
(4) 8' x 2" Mount Pipe	A	From Leg	4.000	0.000	168'	No Ice	1.900	1.900	0.029
			0'			1/2" Ice	2.728	2.728	0.044
			0'			1" Ice	3.401	3.401	0.063
						2" Ice	4.396	4.396	0.119
(4) 8' x 2" Mount Pipe	B	From Leg	4.000	0.000	168'	No Ice	1.900	1.900	0.029
			0'			1/2" Ice	2.728	2.728	0.044
			0'			1" Ice	3.401	3.401	0.063
						2" Ice	4.396	4.396	0.119
(4) 8' x 2" Mount Pipe	C	From Leg	4.000	0.000	168'	No Ice	1.900	1.900	0.029
			0'			1/2" Ice	2.728	2.728	0.044
			0'			1" Ice	3.401	3.401	0.063
						2" Ice	4.396	4.396	0.119
10' horizontal x 2" Pipe Mount	A	From Leg	4.000	0.000	168'	No Ice	1.900	0.010	0.027
			0'			1/2" Ice	2.920	0.040	0.042
			0'			1" Ice	3.970	0.090	0.063
						2" Ice	5.650	0.210	0.126
10' horizontal x 2" Pipe Mount	B	From Leg	4.000	0.000	168'	No Ice	1.900	0.010	0.027
			0'			1/2" Ice	2.920	0.040	0.042
			0'			1" Ice	3.970	0.090	0.063
						2" Ice	5.650	0.210	0.126
10' horizontal x 2" Pipe Mount	C	From Leg	4.000	0.000	168'	No Ice	1.900	0.010	0.027
			0'			1/2" Ice	2.920	0.040	0.042
			0'			1" Ice	3.970	0.090	0.063
						2" Ice	5.650	0.210	0.126
Site Pro1 VFA12-HD	A	From Leg	4.000	0.000	168'	No Ice	13.200	13.200	0.658
			0'			1/2" Ice	19.500	19.500	0.804

tnxTower B+T Group 1717 S, Boulder, Suite 300 Tulsa, OK 74119 Phone: (918) 587-4630 FAX: (918) 587-4630	Job	Page
	100736.010.01.0001 - TRURO, MA (BU# 841273)	18 of 39
	Project	Date
		14:41:12 09/21/22
Client	Crown Castle	Designed by
		Nithish Acharya

Description	Face or Leg	Offset Type	Offsets:		Azimuth Adjustment	Placement	C _{AA} Front	C _{AA} Side	Weight	
			Horz	Lateral						
			ft	ft	°	ft	ft ²	ft ²	K	
RRUS 32 B66	C	From Leg	4.000	0'	0.000	145'	2" Ice	3.675	2.458	0.157
							No Ice	2.743	1.668	0.053
							1/2" Ice	2.965	1.855	0.074
							1" Ice	3.194	2.049	0.098
							2" Ice	3.675	2.458	0.157
RRUS 32	A	From Leg	4.000	0'	0.000	145'	No Ice	2.857	1.777	0.055
							1/2" Ice	3.083	1.968	0.077
							1" Ice	3.316	2.166	0.103
							2" Ice	3.805	2.583	0.165
							No Ice	2.857	1.777	0.055
RRUS 32	B	From Leg	4.000	0'	0.000	145'	1/2" Ice	3.083	1.968	0.077
							1" Ice	3.316	2.166	0.103
							2" Ice	3.805	2.583	0.165
							No Ice	2.857	1.777	0.055
							1/2" Ice	3.083	1.968	0.077
RRUS 32	C	From Leg	4.000	0'	0.000	145'	1" Ice	3.316	2.166	0.103
							2" Ice	3.805	2.583	0.165
							No Ice	2.857	1.777	0.055
							1/2" Ice	3.083	1.968	0.077
							1" Ice	3.316	2.166	0.103
(2) DBC0061F1V51-2	A	From Leg	4.000	0'	0.000	145'	2" Ice	3.805	2.583	0.165
							No Ice	0.433	0.413	0.025
							1/2" Ice	0.518	0.496	0.031
							1" Ice	0.609	0.586	0.038
							2" Ice	0.815	0.788	0.057
(2) DBC0061F1V51-2	B	From Leg	4.000	0'	0.000	145'	No Ice	0.433	0.413	0.025
							1/2" Ice	0.518	0.496	0.031
							1" Ice	0.609	0.586	0.038
							2" Ice	0.815	0.788	0.057
							No Ice	0.433	0.413	0.025
(2) DBC0061F1V51-2	C	From Leg	4.000	0'	0.000	145'	1" Ice	0.609	0.586	0.038
							2" Ice	0.815	0.788	0.057
							No Ice	0.433	0.413	0.025
							1/2" Ice	0.518	0.496	0.031
							1" Ice	0.609	0.586	0.038
(2) RRUS 11	A	From Leg	4.000	0'	0.000	145'	2" Ice	0.815	0.788	0.057
							No Ice	2.784	1.187	0.048
							1/2" Ice	2.992	1.334	0.068
							1" Ice	3.207	1.490	0.092
							2" Ice	3.658	1.833	0.150
(2) RRUS 11	B	From Leg	4.000	0'	0.000	145'	No Ice	2.784	1.187	0.048
							1/2" Ice	2.992	1.334	0.068
							1" Ice	3.207	1.490	0.092
							2" Ice	3.658	1.833	0.150
							No Ice	2.784	1.187	0.048
(2) RRUS 11	C	From Leg	4.000	0'	0.000	145'	1/2" Ice	2.992	1.334	0.068
							1" Ice	3.207	1.490	0.092
							2" Ice	3.658	1.833	0.150
							No Ice	2.784	1.187	0.048
							1/2" Ice	2.992	1.334	0.068
DC6-48-60-18-8F	A	From Leg	4.000	0'	0.000	145'	1" Ice	3.207	1.490	0.092
							2" Ice	3.658	1.833	0.150
							No Ice	0.850	0.850	0.019
							1/2" Ice	1.356	1.356	0.036
							1" Ice	1.532	1.532	0.055
DC6-48-60-18-8F	A	From Leg	4.000	0'	0.000	145'	2" Ice	1.914	1.914	0.101
							No Ice	0.850	0.850	0.019
							1/2" Ice	1.356	1.356	0.036
							1" Ice	1.532	1.532	0.055
							2" Ice	1.914	1.914	0.101
8' x 2" Pipe Mount	A	From Leg	4.000	0'	0.000	145'	No Ice	1.900	1.900	0.029
							1/2" Ice	2.728	2.728	0.044
							1" Ice	3.401	3.401	0.063
							2" Ice	4.396	4.396	0.119
							No Ice	1.900	1.900	0.029
8' x 2" Pipe Mount	B	From Leg	4.000	0'	0.000	145'	1/2" Ice	2.728	2.728	0.044
							1" Ice	3.401	3.401	0.063
							2" Ice	4.396	4.396	0.119
							No Ice	1.900	1.900	0.029
							1/2" Ice	2.728	2.728	0.044

tnxTower B+T Group 1717 S, Boulder, Suite 300 Tulsa, OK 74119 Phone: (918) 587-4630 FAX: (918) 587-4630	Job 100736.010.01.0001 - TRURO, MA (BU# 841273)	Page 19 of 39
	Project	Date 14:41:12 09/21/22
	Client Crown Castle	Designed by Nithish Acharya

Description	Face or Leg	Offset Type	Offsets:		Azimuth Adjustment	Placement	C _{AA} Front	C _{AA} Side	Weight
			Horz	Lateral					
			ft	ft	°	ft	ft ²	ft ²	K
8' x 2" Pipe Mount	C	From Leg	4.000	0.000	145'	No Ice	1.900	1.900	0.029
			0'			1/2" Ice	2.728	2.728	0.044
			0'			1" Ice	3.401	3.401	0.063
						2" Ice	4.396	4.396	0.119
Pipe Mount [PM 601-3]	C	None		0.000	145'	No Ice	3.170	3.170	0.195
						1/2" Ice	3.790	3.790	0.232
						1" Ice	4.420	4.420	0.279
						2" Ice	5.760	5.760	0.401
Sector Mount [SM 702-3]	C	None		0.000	145'	No Ice	38.890	38.890	1.551
						1/2" Ice	50.400	50.400	2.279
						1" Ice	61.770	61.770	3.217
						2" Ice	84.350	84.350	5.705
* Pipe Mount [PM 601-1]	C	From Leg	0.500	0.000	139'	No Ice	1.320	1.320	0.065
			0'			1/2" Ice	1.580	1.580	0.077
			0'			1" Ice	1.840	1.840	0.093
						2" Ice	2.400	2.400	0.134
* LNX-6514DS-A1M w/ Mount Pipe	A	From Leg	4.000	0.000	130'	No Ice	4.095	3.296	0.065
			0'			1/2" Ice	4.485	3.675	0.128
			1'			1" Ice	4.885	4.064	0.202
						2" Ice	5.712	4.869	0.383
LNX-6514DS-A1M w/ Mount Pipe	B	From Leg	4.000	0.000	130'	No Ice	4.095	3.296	0.065
			0'			1/2" Ice	4.485	3.675	0.128
			1'			1" Ice	4.885	4.064	0.202
						2" Ice	5.712	4.869	0.383
LNX-6514DS-A1M w/ Mount Pipe	C	From Leg	4.000	0.000	130'	No Ice	4.095	3.296	0.065
			0'			1/2" Ice	4.485	3.675	0.128
			1'			1" Ice	4.885	4.064	0.202
						2" Ice	5.712	4.869	0.383
X7C-665-2 w/ Mount Pipe	A	From Leg	4.000	0.000	130'	No Ice	7.546	5.661	0.069
			0'			1/2" Ice	8.242	6.331	0.133
			1'			1" Ice	8.955	7.018	0.208
						2" Ice	10.429	8.440	0.392
X7C-665-2 w/ Mount Pipe	B	From Leg	4.000	0.000	130'	No Ice	7.546	5.661	0.069
			0'			1/2" Ice	8.242	6.331	0.133
			1'			1" Ice	8.955	7.018	0.208
						2" Ice	10.429	8.440	0.392
X7C-680-2 w/ Mount Pipe	C	From Leg	4.000	0.000	130'	No Ice	7.281	5.911	0.068
			0'			1/2" Ice	7.954	6.565	0.133
			1'			1" Ice	8.642	7.235	0.210
						2" Ice	10.066	8.620	0.396
HBXX-6516DS-A2M w/ Mount Pipe	A	From Leg	4.000	0.000	130'	No Ice	5.180	3.970	0.050
			0'			1/2" Ice	5.701	4.468	0.094
			1'			1" Ice	6.239	4.981	0.147
						2" Ice	7.361	6.056	0.280
HBXX-6516DS-A2M w/ Mount Pipe	B	From Leg	4.000	0.000	130'	No Ice	5.180	3.970	0.050
			0'			1/2" Ice	5.701	4.468	0.094
			1'			1" Ice	6.239	4.981	0.147
						2" Ice	7.361	6.056	0.280
HBXX-6516DS-A2M w/ Mount Pipe	C	From Leg	4.000	0.000	130'	No Ice	5.180	3.970	0.050
			0'			1/2" Ice	5.701	4.468	0.094
			1'			1" Ice	6.239	4.981	0.147
						2" Ice	7.361	6.056	0.280
SBNHH-1D65B w/ Mount Pipe	A	From Leg	4.000	0.000	130'	No Ice	4.095	3.296	0.066
			0'			1/2" Ice	4.486	3.676	0.130
			1'			1" Ice	4.887	4.066	0.204

tnxTower B+T Group 1717 S, Boulder, Suite 300 Tulsa, OK 74119 Phone: (918) 587-4630 FAX: (918) 587-4630	Job	100736.010.01.0001 - TRURO, MA (BU# 841273)	Page	20 of 39
	Project		Date	14:41:12 09/21/22
	Client	Crown Castle		Designed by

Description	Face or Leg	Offset Type	Offsets:		Azimuth Adjustment	Placement	C _{AA} Front	C _{AA} Side	Weight
			Horz	Lateral					
SBNHH-1D65B w/ Mount Pipe	B	From Leg	4.000	0.000	130'	2" Ice	5.715	4.872	0.386
						No Ice	4.095	3.296	0.066
						1/2" Ice	4.486	3.676	0.130
						1" Ice	4.887	4.066	0.204
SBNHH-1D65B w/ Mount Pipe	C	From Leg	4.000	0.000	130'	2" Ice	5.715	4.872	0.386
						No Ice	4.095	3.296	0.066
						1/2" Ice	4.486	3.676	0.130
						1" Ice	4.887	4.066	0.204
DB-B1-6C-12AB-0Z	A	From Leg	4.000	0.000	130'	2" Ice	5.715	4.872	0.386
						No Ice	3.364	2.192	0.021
						1/2" Ice	3.597	2.395	0.050
						1" Ice	3.838	2.606	0.082
DB-B1-6C-12AB-0Z	C	From Leg	4.000	0.000	130'	2" Ice	4.343	3.049	0.158
						No Ice	3.364	2.192	0.021
						1/2" Ice	3.597	2.395	0.050
						1" Ice	3.838	2.606	0.082
RRH2X60-AWS	A	From Leg	4.000	0.000	130'	2" Ice	4.343	3.049	0.158
						No Ice	3.500	1.816	0.060
						1/2" Ice	3.761	2.052	0.083
						1" Ice	4.029	2.289	0.109
RRH2X60-AWS	B	From Leg	4.000	0.000	130'	2" Ice	4.585	2.785	0.173
						No Ice	3.500	1.816	0.060
						1/2" Ice	3.761	2.052	0.083
						1" Ice	4.029	2.289	0.109
RRH2X60-AWS	C	From Leg	4.000	0.000	130'	2" Ice	4.585	2.785	0.173
						No Ice	3.500	1.816	0.060
						1/2" Ice	3.761	2.052	0.083
						1" Ice	4.029	2.289	0.109
5' x 2" Pipe Mount	A	From Leg	4.000	0.000	130'	2" Ice	4.585	2.785	0.173
						No Ice	1.188	1.188	0.018
						1/2" Ice	1.496	1.496	0.027
						1" Ice	1.807	1.807	0.040
5' x 2" Pipe Mount	B	From Leg	4.000	0.000	130'	2" Ice	2.458	2.458	0.076
						No Ice	1.188	1.188	0.018
						1/2" Ice	1.496	1.496	0.027
						1" Ice	1.807	1.807	0.040
5' x 2" Pipe Mount	C	From Leg	4.000	0.000	130'	2" Ice	2.458	2.458	0.076
						No Ice	1.188	1.188	0.018
						1/2" Ice	1.496	1.496	0.027
						1" Ice	1.807	1.807	0.040
Pipe Mount [PM 601-3]	C	None	0.000	130'	2" Ice	2.458	2.458	0.076	
					No Ice	3.170	3.170	0.195	
					1/2" Ice	3.790	3.790	0.232	
					1" Ice	4.420	4.420	0.279	
Sector Mount [SM 702-3]	C	None	0.000	130'	2" Ice	5.760	5.760	0.401	
					No Ice	38.890	38.890	1.551	
					1/2" Ice	50.400	50.400	2.279	
					1" Ice	61.770	61.770	3.217	
* MX08FRO665-21 w/ Mount Pipe	A	From Leg	4.000	0.000	122'	2" Ice	84.350	84.350	5.705
						No Ice	8.009	4.233	0.108
						1/2" Ice	8.518	4.689	0.194
						1" Ice	9.038	5.156	0.292
MX08FRO665-21 w/ Mount Pipe	B	From Leg	4.000	0.000	122'	2" Ice	10.109	6.122	0.522
						No Ice	8.009	4.233	0.108
						1/2" Ice	8.518	4.689	0.194
						1" Ice	9.038	5.156	0.292

tnxTower B+T Group 1717 S, Boulder, Suite 300 Tulsa, OK 74119 Phone: (918) 587-4630 FAX: (918) 587-4630	Job 100736.010.01.0001 - TRURO, MA (BU# 841273)	Page 21 of 39
	Project	Date 14:41:12 09/21/22
	Client Crown Castle	Designed by Nithish Acharya

Description	Face or Leg	Offset Type	Offsets:		Azimuth Adjustment	Placement	C _{AA} Front	C _{AA} Side	Weight
			Horz	Lateral					
MX08FRO665-21 w/ Mount Pipe	C	From Leg	4.000	0.000	122'	2" Ice	10.109	6.122	0.522
						No Ice	8.009	4.233	0.108
						1/2" Ice	8.518	4.689	0.194
						1" Ice	9.038	5.156	0.292
TA08025-B604	A	From Leg	4.000	0.000	122'	2" Ice	10.109	6.122	0.522
						No Ice	1.964	0.981	0.064
						1/2" Ice	2.138	1.112	0.081
						1" Ice	2.320	1.250	0.100
TA08025-B604	B	From Leg	4.000	0.000	122'	2" Ice	2.705	1.548	0.148
						No Ice	1.964	0.981	0.064
						1/2" Ice	2.138	1.112	0.081
						1" Ice	2.320	1.250	0.100
TA08025-B604	C	From Leg	4.000	0.000	122'	2" Ice	2.705	1.548	0.148
						No Ice	1.964	0.981	0.064
						1/2" Ice	2.138	1.112	0.081
						1" Ice	2.320	1.250	0.100
TA08025-B605	A	From Leg	4.000	0.000	122'	2" Ice	2.705	1.548	0.148
						No Ice	1.964	1.129	0.075
						1/2" Ice	2.138	1.267	0.093
						1" Ice	2.320	1.411	0.114
TA08025-B605	B	From Leg	4.000	0.000	122'	2" Ice	2.705	1.723	0.164
						No Ice	1.964	1.129	0.075
						1/2" Ice	2.138	1.267	0.093
						1" Ice	2.320	1.411	0.114
TA08025-B605	C	From Leg	4.000	0.000	122'	2" Ice	2.705	1.723	0.164
						No Ice	1.964	1.129	0.075
						1/2" Ice	2.138	1.267	0.093
						1" Ice	2.320	1.411	0.114
RDIDC-9181-PF-48	A	From Leg	4.000	0.000	122'	2" Ice	2.705	1.723	0.164
						No Ice	2.012	1.168	0.022
						1/2" Ice	2.189	1.311	0.040
						1" Ice	2.373	1.461	0.060
(2) 8' x 2" Mount Pipe	A	From Leg	4.000	0.000	122'	2" Ice	2.763	1.784	0.110
						No Ice	1.900	1.900	0.029
						1/2" Ice	2.728	2.728	0.044
						1" Ice	3.401	3.401	0.063
(2) 8' x 2" Mount Pipe	B	From Leg	4.000	0.000	122'	2" Ice	4.396	4.396	0.119
						No Ice	1.900	1.900	0.029
						1/2" Ice	2.728	2.728	0.044
						1" Ice	3.401	3.401	0.063
(2) 8' x 2" Mount Pipe	C	From Leg	4.000	0.000	122'	2" Ice	4.396	4.396	0.119
						No Ice	1.900	1.900	0.029
						1/2" Ice	2.728	2.728	0.044
						1" Ice	3.401	3.401	0.063
Commscope MTC3975083 (3)	C	None	0.000	122'	No Ice	23.850	23.850	1.260	
					1/2" Ice	34.120	34.120	1.803	
					1" Ice	44.390	44.390	2.345	
					2" Ice	64.930	64.930	3.431	
* ANT150F2	A	From Face	4.000	0.000	104'	No Ice	1.227	1.227	0.013
						1/2" Ice	1.530	1.530	0.022
						1" Ice	1.842	1.842	0.035
						2" Ice	2.494	2.494	0.072
AO8610-5T0	A	From Face	4.000	0.000	104'	No Ice	3.960	3.960	0.041
						1/2" Ice	5.638	5.638	0.071
						1" Ice	7.333	7.333	0.111

tnxTower B+T Group 1717 S, Boulder, Suite 300 Tulsa, OK 74119 Phone: (918) 587-4630 FAX: (918) 587-4630	Job	100736.010.01.0001 - TRURO, MA (BU# 841273)	Page	22 of 39
	Project		Date	14:41:12 09/21/22
	Client	Crown Castle		Designed by

Description	Face or Leg	Offset Type	Offsets:		Azimuth Adjustment	Placement	C _{AA} Front	C _{AA} Side	Weight
			Horz	Lateral					
K751221	A	From Face	4.000	0.000	104'	2" Ice	10.773	10.773	0.223
						No Ice	0.314	0.314	0.004
						1/2" Ice	0.445	0.445	0.008
						1" Ice	0.585	0.585	0.013
						2" Ice	0.894	0.894	0.028
SRL-210C-4	B	From Face	4.000	0.000	104'	No Ice	1.000	1.000	0.059
						1/2" Ice	1.800	1.800	0.077
						1" Ice	2.600	2.600	0.094
						2" Ice	4.200	4.200	0.130
						No Ice	4.800	4.800	0.030
ANT150F6	B	From Face	4.000	0.000	104'	1/2" Ice	6.828	6.828	0.066
						1" Ice	8.873	8.873	0.114
						2" Ice	13.013	13.013	0.249
						No Ice	6.050	6.050	0.023
						1/2" Ice	8.281	8.281	0.067
PD220-5	B	From Face	4.000	0.000	104'	1" Ice	10.529	10.529	0.125
						2" Ice	15.075	15.075	0.283
						No Ice	3.960	3.960	0.041
						1/2" Ice	5.638	5.638	0.071
						1" Ice	7.333	7.333	0.111
AO8610-5T0	C	From Face	4.000	0.000	104'	2" Ice	10.773	10.773	0.223
						No Ice	0.640	0.640	0.005
						1/2" Ice	0.941	0.941	0.010
						1" Ice	1.191	1.191	0.018
						2" Ice	1.720	1.720	0.043
10191	C	From Face	4.000	0.000	104'	No Ice	4.500	4.500	0.066
						1/2" Ice	6.329	6.329	0.099
						1" Ice	8.175	8.175	0.144
						2" Ice	11.917	11.917	0.268
						No Ice	1.425	1.425	0.022
(4) 6' x 2" Mount Pipe	A	From Face	4.000	0.000	104'	1/2" Ice	1.925	1.925	0.033
						1" Ice	2.294	2.294	0.048
						2" Ice	3.060	3.060	0.090
						No Ice	1.425	1.425	0.022
						1/2" Ice	1.925	1.925	0.033
(4) 6' x 2" Mount Pipe	B	From Face	4.000	0.000	104'	1" Ice	2.294	2.294	0.048
						2" Ice	3.060	3.060	0.090
						No Ice	1.425	1.425	0.022
						1/2" Ice	1.925	1.925	0.033
						1" Ice	2.294	2.294	0.048
(4) 6' x 2" Mount Pipe	C	From Face	4.000	0.000	104'	2" Ice	3.060	3.060	0.090
						No Ice	1.425	1.425	0.022
						1/2" Ice	1.925	1.925	0.033
						1" Ice	2.294	2.294	0.048
						2" Ice	3.060	3.060	0.090
6' x 2.375" Mount Pipe	C	From Face	4.000	0.000	104'	No Ice	1.425	1.425	0.041
						1/2" Ice	1.925	1.925	0.051
						1" Ice	2.294	2.294	0.066
						2" Ice	3.060	3.060	0.109
						No Ice	1.425	1.425	0.041
6' x 2.375" Mount Pipe	A	From Face	4.000	0.000	104'	1/2" Ice	1.925	1.925	0.051
						1" Ice	2.294	2.294	0.066
						2" Ice	3.060	3.060	0.109
						No Ice	1.425	1.425	0.041
						1/2" Ice	1.925	1.925	0.051
Sabre 30' Specialty Platform	C	None		0.000	104'	No Ice	75.000	75.000	3.020
						1/2" Ice	87.000	87.000	3.620
						1" Ice	99.000	99.000	4.220
						2" Ice	123.000	123.000	5.420
						No Ice	3.193	1.977	0.090
* ERICSSON AIR 21 B4A B2P	A	From Leg	4.000	0.000	96'	1/2" Ice	3.518	2.281	0.132
						1" Ice	3.852	2.593	0.179
						1'			

tnxTower B+T Group 1717 S, Boulder, Suite 300 Tulsa, OK 74119 Phone: (918) 587-4630 FAX: (918) 587-4630	Job		100736.010.01.0001 - TRURO, MA (BU# 841273)		Page		23 of 39	
	Project				Date		14:41:12 09/21/22	
	Client		Crown Castle		Designed by		Nithish Acharya	

Description	Face or Leg	Offset Type	Offsets:		Azimuth Adjustment	Placement	C _{AA} Front	C _{AA} Side	Weight
			Horz	Lateral					
ERICSSON AIR 21 B4A B2P	B	From Leg	4.000	0.000	96'	2" Ice	4.549	3.246	0.289
						No Ice	3.193	1.977	0.090
						1/2" Ice	3.518	2.281	0.132
						1" Ice	3.852	2.593	0.179
ERICSSON AIR 21 B4A B2P	C	From Leg	4.000	0.000	96'	2" Ice	4.549	3.246	0.289
						No Ice	3.193	1.977	0.090
						1/2" Ice	3.518	2.281	0.132
						1" Ice	3.852	2.593	0.179
APXVAARR24_43-U-NA20 w/ Mount Pipe	A	From Leg	4.000	0.000	96'	2" Ice	4.549	3.246	0.289
						No Ice	14.694	6.873	0.186
						1/2" Ice	15.455	7.554	0.315
						1" Ice	16.230	8.247	0.458
APXVAARR24_43-U-NA20 w/ Mount Pipe	B	From Leg	4.000	0.000	96'	2" Ice	17.816	9.670	0.788
						No Ice	14.694	6.873	0.186
						1/2" Ice	15.455	7.554	0.315
						1" Ice	16.230	8.247	0.458
APXVAARR24_43-U-NA20 w/ Mount Pipe	C	From Leg	4.000	0.000	96'	2" Ice	17.816	9.670	0.788
						No Ice	14.694	6.873	0.186
						1/2" Ice	15.455	7.554	0.315
						1" Ice	16.230	8.247	0.458
RRUS 11 B2	A	From Leg	4.000	0.000	96'	2" Ice	17.816	9.670	0.788
						No Ice	2.833	1.182	0.051
						1/2" Ice	3.043	1.330	0.072
						1" Ice	3.259	1.485	0.095
RRUS 11 B2	B	From Leg	4.000	0.000	96'	2" Ice	3.715	1.826	0.153
						No Ice	2.833	1.182	0.051
						1/2" Ice	3.043	1.330	0.072
						1" Ice	3.259	1.485	0.095
RRUS 11 B2	C	From Leg	4.000	0.000	96'	2" Ice	3.715	1.826	0.153
						No Ice	2.833	1.182	0.051
						1/2" Ice	3.043	1.330	0.072
						1" Ice	3.259	1.485	0.095
ATM1900D-1A20	A	From Leg	4.000	0.000	96'	2" Ice	3.715	1.826	0.153
						No Ice	0.717	0.192	0.008
						1/2" Ice	0.824	0.255	0.013
						1" Ice	0.938	0.326	0.020
ATM1900D-1A20	B	From Leg	4.000	0.000	96'	2" Ice	1.189	0.494	0.039
						No Ice	0.717	0.192	0.008
						1/2" Ice	0.824	0.255	0.013
						1" Ice	0.938	0.326	0.020
ATM1900D-1A20	C	From Leg	4.000	0.000	96'	2" Ice	1.189	0.494	0.039
						No Ice	0.717	0.192	0.008
						1/2" Ice	0.824	0.255	0.013
						1" Ice	0.938	0.326	0.020
RADIO 4449 B12/B71	A	From Leg	4.000	0.000	96'	2" Ice	1.189	0.494	0.039
						No Ice	1.650	1.163	0.074
						1/2" Ice	1.810	1.301	0.090
						1" Ice	1.978	1.447	0.109
RADIO 4449 B12/B71	B	From Leg	4.000	0.000	96'	2" Ice	2.336	1.762	0.155
						No Ice	1.650	1.163	0.074
						1/2" Ice	1.810	1.301	0.090
						1" Ice	1.978	1.447	0.109
RADIO 4449 B12/B71	C	From Leg	4.000	0.000	96'	2" Ice	2.336	1.762	0.155
						No Ice	1.650	1.163	0.074
						1/2" Ice	1.810	1.301	0.090
						1" Ice	1.978	1.447	0.109
RADIO 4449 B12/B71		From Leg	4.000	0.000	96'	2" Ice	2.336	1.762	0.155
						No Ice	1.650	1.163	0.074
						1/2" Ice	1.810	1.301	0.090
						1" Ice	1.978	1.447	0.109

tnxTower B+T Group 1717 S, Boulder, Suite 300 Tulsa, OK 74119 Phone: (918) 587-4630 FAX: (918) 587-4630	Job 100736.010.01.0001 - TRURO, MA (BU# 841273)	Page 24 of 39
	Project	Date 14:41:12 09/21/22
	Client Crown Castle	Designed by Nithish Acharya

Description	Face or Leg	Offset Type	Offsets:		Azimuth Adjustment	Placement	C _{AA} Front	C _{AA} Side	Weight
			Horz Lateral	Vert					
Sector Mount [SM 403-3]	C	None			0.000	96'	No Ice 19.400 1/2" Ice 27.200 1" Ice 34.930 2" Ice 50.180	19.400 27.200 34.930 50.180	0.873 1.244 1.744 3.131
*									
Side Arm Mount [SO 201-1]	C	From Leg	0.500 0' 0'		0.000	87'	No Ice 1.780 1/2" Ice 2.240 1" Ice 2.750 2" Ice 3.890	2.610 3.150 3.730 4.990	0.096 0.116 0.144 0.221
*									
GPS-TMG-HR-26N	C	From Leg	3.000 0' 2'		0.000	71'	No Ice 0.208 1/2" Ice 0.268 1" Ice 0.334 2" Ice 0.490	0.133 0.183 0.239 0.375	0.001 0.003 0.006 0.017
6' x 2" Mount Pipe	C	From Leg	3.000 0' 0'		0.000	71'	No Ice 1.425 1/2" Ice 1.925 1" Ice 2.294 2" Ice 3.060	1.425 1.925 2.294 3.060	0.022 0.033 0.048 0.090
Side Arm Mount [SO 601-1]	C	From Leg	1.500 0' 0'		0.000	71'	No Ice 1.040 1/2" Ice 1.410 1" Ice 1.780 2" Ice 2.520	5.320 6.430 7.670 10.670	0.159 0.196 0.241 0.359
*									
*									
*									
*									
*									
*									
*									
*									
*									
*									
*									
*									

Dishes

Description	Face or Leg	Dish Type	Offset Type	Offsets:		Azimuth Adjustment	3 dB Beam Width	Elevation	Outside Diameter	Aperture Area	Weight
				Horz Lateral	Vert						
Andrew PAR6-59A	C	Paraboloid w/Radome	From Leg	0.500 0' -1'		11.000		139'	6.000	No Ice 28.274 1/2" Ice 29.065 1" Ice 29.856 2" Ice 31.438	0.143 0.292 0.441 0.740
*											
COMMSCOPE VHLPX4-11W-6WH	C	Paraboloid w/Shroud (HP)	From Face	4.000 0' 2'		-19.000		104'	4.108	No Ice 13.256 1/2" Ice 13.800 1" Ice 14.343 2" Ice 15.429	0.088 0.159 0.230 0.371

tnxTower

B+T Group
 1717 S, Boulder, Suite 300
 Tulsa, OK 74119
 Phone: (918) 587-4630
 FAX: (918) 587-4630

Job
 100736.010.01.0001 - TRURO, MA (BU# 841273)

Page
 25 of 39

Project
 Date
 14:41:12 09/21/22

Client
 Crown Castle
 Designed by
 Nithish Acharya

Description	Face or Leg	Dish Type	Offset Type	Offsets: Horz Lateral Vert ft	Azimuth Adjustment °	3 dB Beam Width °	Elevation ft	Outside Diameter ft	Aperture Area ft ²	Weight K	
COMMSCOPE VHLPX4-11W-6WH	A	Paraboloid w/Shroud (HP)	From Face	4.000	1.000		104'	4.108	No Ice	13.256	0.088
				0'					1/2" Ice	13.800	0.159
				2'					1" Ice	14.343	0.230
									2" Ice	15.429	0.371
*											
PR-950	C	Grid	From Leg	1.500	1.000		87'	5.667	No Ice	25.220	0.038
				0'					1/2" Ice	25.967	0.171
				0'					1" Ice	26.714	0.305
									2" Ice	28.209	0.571
*											

Load Combinations

Comb. No.	Description
1	Dead Only
2	1.2 Dead+1.0 Wind 0 deg - No Ice
3	0.9 Dead+1.0 Wind 0 deg - No Ice
4	1.2 Dead+1.0 Wind 30 deg - No Ice
5	0.9 Dead+1.0 Wind 30 deg - No Ice
6	1.2 Dead+1.0 Wind 60 deg - No Ice
7	0.9 Dead+1.0 Wind 60 deg - No Ice
8	1.2 Dead+1.0 Wind 90 deg - No Ice
9	0.9 Dead+1.0 Wind 90 deg - No Ice
10	1.2 Dead+1.0 Wind 120 deg - No Ice
11	0.9 Dead+1.0 Wind 120 deg - No Ice
12	1.2 Dead+1.0 Wind 150 deg - No Ice
13	0.9 Dead+1.0 Wind 150 deg - No Ice
14	1.2 Dead+1.0 Wind 180 deg - No Ice
15	0.9 Dead+1.0 Wind 180 deg - No Ice
16	1.2 Dead+1.0 Wind 210 deg - No Ice
17	0.9 Dead+1.0 Wind 210 deg - No Ice
18	1.2 Dead+1.0 Wind 240 deg - No Ice
19	0.9 Dead+1.0 Wind 240 deg - No Ice
20	1.2 Dead+1.0 Wind 270 deg - No Ice
21	0.9 Dead+1.0 Wind 270 deg - No Ice
22	1.2 Dead+1.0 Wind 300 deg - No Ice
23	0.9 Dead+1.0 Wind 300 deg - No Ice
24	1.2 Dead+1.0 Wind 330 deg - No Ice
25	0.9 Dead+1.0 Wind 330 deg - No Ice
26	1.2 Dead+1.0 Ice+1.0 Temp
27	1.2 Dead+1.0 Wind 0 deg+1.0 Ice+1.0 Temp
28	1.2 Dead+1.0 Wind 30 deg+1.0 Ice+1.0 Temp
29	1.2 Dead+1.0 Wind 60 deg+1.0 Ice+1.0 Temp
30	1.2 Dead+1.0 Wind 90 deg+1.0 Ice+1.0 Temp
31	1.2 Dead+1.0 Wind 120 deg+1.0 Ice+1.0 Temp
32	1.2 Dead+1.0 Wind 150 deg+1.0 Ice+1.0 Temp
33	1.2 Dead+1.0 Wind 180 deg+1.0 Ice+1.0 Temp
34	1.2 Dead+1.0 Wind 210 deg+1.0 Ice+1.0 Temp
35	1.2 Dead+1.0 Wind 240 deg+1.0 Ice+1.0 Temp
36	1.2 Dead+1.0 Wind 270 deg+1.0 Ice+1.0 Temp
37	1.2 Dead+1.0 Wind 300 deg+1.0 Ice+1.0 Temp
38	1.2 Dead+1.0 Wind 330 deg+1.0 Ice+1.0 Temp
39	Dead+Wind 0 deg - Service
40	Dead+Wind 30 deg - Service
41	Dead+Wind 60 deg - Service

tnxTower B+T Group 1717 S, Boulder, Suite 300 Tulsa, OK 74119 Phone: (918) 587-4630 FAX: (918) 587-4630	Job 100736.010.01.0001 - TRURO, MA (BU# 841273)	Page 26 of 39
	Project	Date 14:41:12 09/21/22
	Client Crown Castle	Designed by Nithish Acharya

Comb. No.	Description
42	Dead+Wind 90 deg - Service
43	Dead+Wind 120 deg - Service
44	Dead+Wind 150 deg - Service
45	Dead+Wind 180 deg - Service
46	Dead+Wind 210 deg - Service
47	Dead+Wind 240 deg - Service
48	Dead+Wind 270 deg - Service
49	Dead+Wind 300 deg - Service
50	Dead+Wind 330 deg - Service

Maximum Member Forces

Section No.	Elevation ft	Component Type	Condition	Gov. Load Comb.	Axial K	Major Axis Moment kip-ft	Minor Axis Moment kip-ft
T1	170 - 160	Leg	Max Tension	23	4.300	-1.078	0.020
			Max. Compression	18	-7.736	-0.312	-0.037
			Max. Mx	14	-0.016	2.307	-0.020
			Max. My	8	-1.641	-0.044	-2.262
			Max. Vy	6	-1.238	0.000	0.000
			Max. Vx	12	-1.275	0.000	0.000
		Diagonal	Max Tension	4	3.333	0.000	0.000
			Max. Compression	16	-3.354	0.000	0.000
			Max. Mx	32	0.363	0.051	0.006
			Max. My	30	-0.871	0.049	-0.007
			Max. Vy	32	0.050	0.051	0.006
			Max. Vx	30	0.003	0.000	0.000
		Top Girt	Max Tension	19	0.248	0.000	0.000
			Max. Compression	14	-0.291	0.000	0.000
			Max. Mx	26	-0.077	-0.141	0.000
			Max. My	26	-0.074	0.000	0.004
Max. Vy	26		0.071	0.000	0.000		
Max. Vx	26		-0.002	0.000	0.000		
T2	160 - 140	Leg	Max Tension	15	31.017	-1.419	0.025
			Max. Compression	18	-40.935	0.864	-0.106
			Max. Mx	22	18.211	-1.532	0.181
			Max. My	21	-1.678	-0.033	1.507
			Max. Vy	22	-1.747	-1.532	0.181
		Diagonal	Max. Vx	12	-1.744	0.027	0.356
			Max Tension	8	8.793	0.000	0.000
			Max. Compression	20	-8.889	0.000	0.000
			Max. Mx	36	1.708	0.109	-0.012
			Max. My	22	-7.787	0.030	0.017
T3	140 - 120	Leg	Max. Vy	33	0.083	0.105	-0.014
			Max. Vx	37	-0.005	0.000	0.000
			Max Tension	7	75.895	-1.530	0.036
			Max. Compression	18	-95.003	1.372	-0.004
			Max. Mx	14	56.172	1.959	0.005
		Diagonal	Max. My	24	-9.097	-0.101	-1.949
			Max. Vy	14	1.120	-1.584	0.005
			Max. Vx	20	1.190	-0.113	-1.848
			Max Tension	8	12.756	0.000	0.000
			Max. Compression	8	-12.897	0.000	0.000
T4	120 - 100	Leg	Max. Mx	35	2.078	0.173	-0.020
			Max. My	10	-11.093	0.033	-0.022
			Max. Vy	33	0.111	0.162	0.019
			Max. Vx	32	0.006	0.000	0.000
			Max Tension	15	130.846	-1.525	0.005
		Diagonal	Max. Compression	10	-160.765	4.329	-0.187

tnxTower B+T Group 1717 S, Boulder, Suite 300 Tulsa, OK 74119 Phone: (918) 587-4630 FAX: (918) 587-4630	Job	100736.010.01.0001 - TRURO, MA (BU# 841273)	Page	27 of 39
	Project		Date	14:41:12 09/21/22
	Client	Crown Castle		Designed by

Section No.	Elevation ft	Component Type	Condition	Gov. Load Comb.	Axial K	Major Axis Moment kip-ft	Minor Axis Moment kip-ft
T5	100 - 80	Diagonal	Max. Mx	3	-155.873	4.349	0.138
			Max. My	12	-12.613	-0.106	-4.096
			Max. Vy	22	1.440	-4.309	0.186
			Max. Vx	24	1.539	0.013	1.128
			Max Tension	4	15.516	0.000	0.000
			Max. Compression	4	-15.693	0.000	0.000
			Max. Mx	35	2.697	0.230	0.028
			Max. My	37	-2.999	0.212	0.030
		Leg	Max. Vy	33	0.141	0.228	-0.029
			Max. Vx	37	-0.007	0.000	0.000
			Max Tension	15	192.757	-2.140	-0.170
			Max. Compression	10	-231.538	3.814	-0.268
			Max. Mx	3	-185.793	4.349	0.138
			Max. My	12	-12.996	-0.106	-4.096
			Max. Vy	22	-1.118	-4.309	0.186
			Max. Vx	24	0.993	-0.051	4.085
T6	80 - 60	Diagonal	Max Tension	4	20.943	0.000	0.000
			Max. Compression	4	-21.079	0.000	0.000
			Max. Mx	35	3.722	0.479	-0.056
			Max. My	10	-19.610	-0.012	-0.061
			Max. Vy	33	0.220	0.440	-0.058
			Max. Vx	32	0.012	0.000	0.000
			Max Tension	15	261.343	-3.331	-0.022
			Max. Compression	2	-310.146	4.565	0.044
		Leg	Max. Mx	2	-310.146	4.565	0.044
			Max. My	12	-20.239	0.014	-4.403
			Max. Vy	2	-0.420	4.565	0.044
			Max. Vx	12	0.641	-0.197	-3.871
			Max Tension	4	22.278	0.000	0.000
			Max. Compression	4	-22.481	0.000	0.000
			Max. Mx	35	3.887	0.612	-0.072
			Max. My	33	-4.565	0.517	-0.075
T7	60 - 40	Diagonal	Max. Vy	33	0.270	0.586	0.070
			Max. Vx	33	0.014	0.000	0.000
			Max Tension	15	328.352	-6.312	-0.014
			Max. Compression	2	-389.310	7.411	-0.003
			Max. Mx	2	-389.310	7.411	-0.003
			Max. My	12	-23.628	-0.186	-6.092
			Max. Vy	22	0.538	-6.273	0.073
			Max. Vx	12	0.525	-0.186	-6.092
		Leg	Max Tension	4	23.547	0.000	0.000
			Max. Compression	2	-24.079	0.000	0.000
			Max. Mx	33	3.039	0.687	-0.085
			Max. My	33	-5.063	0.631	-0.086
			Max. Vy	33	0.293	0.687	-0.085
			Max. Vx	33	0.015	0.000	0.000
			Max Tension	15	393.616	-8.564	-0.041
			Max. Compression	2	-467.770	1.630	-0.705
T8	40 - 20	Diagonal	Max. Mx	14	353.809	-8.628	-0.047
			Max. My	12	-27.443	-0.301	-11.612
			Max. Vy	2	1.004	8.555	0.064
			Max. Vx	12	0.917	-0.301	-11.612
			Max Tension	4	25.317	0.000	0.000
			Max. Compression	2	-26.567	0.000	0.000
			Max. Mx	33	3.354	0.801	0.095
			Max. My	32	3.619	0.800	-0.099
		Leg	Max. Vy	33	0.313	0.801	0.095
			Max. Vx	32	0.016	0.000	0.000
			Max Tension	15	438.312	0.489	-0.282
			Max. Compression	2	-523.334	0.000	0.000
			Max. Mx	2	-523.293	21.305	-0.587

tnxTower B+T Group 1717 S, Boulder, Suite 300 Tulsa, OK 74119 Phone: (918) 587-4630 FAX: (918) 587-4630	Job	100736.010.01.0001 - TRURO, MA (BU# 841273)	Page	28 of 39
	Project		Date	14:41:12 09/21/22
	Client	Crown Castle	Designed by	Nithish Acharya

Section No.	Elevation ft	Component Type	Condition	Gov. Load Comb.	Axial K	Major Axis Moment kip-ft	Minor Axis Moment kip-ft
			Max. My	12	-31.800	-2.021	-11.305
			Max. Vy	10	-5.196	21.235	0.467
			Max. Vx	12	-2.815	-2.021	-11.305
		Diagonal	Max Tension	5	31.906	-0.024	-0.021
			Max. Compression	2	-34.851	0.000	0.000
			Max. Mx	12	-18.489	0.400	-0.029
			Max. My	37	-2.063	0.157	0.052
			Max. Vy	30	-0.159	0.242	0.052
			Max. Vx	31	0.011	0.000	0.000
		Horizontal	Max Tension	2	24.002	-0.272	-0.044
			Max. Compression	2	-25.174	-0.291	-0.053
			Max. Mx	33	0.682	-0.537	-0.003
			Max. My	2	4.010	-0.219	0.129
			Max. Vy	33	-0.229	-0.503	-0.015
			Max. Vx	2	0.013	-0.219	0.129
		Redund Horz 1 Bracing	Max Tension	16	6.039	0.000	0.000
			Max. Compression	5	-4.802	0.000	0.000
			Max. Mx	26	0.412	-0.083	0.000
			Max. My	26	0.467	0.000	0.002
			Max. Vy	26	0.055	0.000	0.000
			Max. Vx	26	-0.002	0.000	0.000
		Redund Diag 1 Bracing	Max Tension	5	3.276	0.000	0.000
			Max. Compression	16	-3.726	0.000	0.000
			Max. Mx	26	0.242	-0.093	0.000
			Max. My	26	0.193	0.000	0.004
			Max. Vy	26	-0.049	0.000	0.000
			Max. Vx	26	-0.002	0.000	0.000
		Inner Bracing	Max Tension	3	0.014	0.000	0.000
			Max. Compression	14	-0.034	0.000	0.000
			Max. Mx	26	-0.023	-0.278	0.000
			Max. Vy	26	0.093	0.000	0.000

Maximum Reactions

Location	Condition	Gov. Load Comb.	Vertical K	Horizontal, X K	Horizontal, Z K
Leg C	Max. Vert	18	537.298	58.063	-33.522
	Max. H _x	18	537.298	58.063	-33.522
	Max. H _z	5	-397.992	-42.379	31.911
	Min. Vert	7	-444.410	-50.332	29.020
	Min. H _x	7	-444.410	-50.332	29.020
	Min. H _z	16	466.646	47.013	-34.480
Leg B	Max. Vert	10	555.928	-61.607	-33.983
	Max. H _x	23	-460.306	53.443	29.359
	Max. H _z	25	-414.789	46.172	31.776
	Min. Vert	23	-460.306	53.443	29.359
	Min. H _x	10	555.928	-61.607	-33.983
	Min. H _z	12	485.608	-51.118	-34.561
Leg A	Max. Vert	2	564.237	-1.598	72.278
	Max. H _x	21	29.434	10.428	2.536
	Max. H _z	2	564.237	-1.598	72.278
	Min. Vert	15	-472.602	1.533	-63.036
	Min. H _x	8	36.636	-10.473	2.919
	Min. H _z	15	-472.602	1.533	-63.036

tnxTower B+T Group 1717 S, Boulder, Suite 300 Tulsa, OK 74119 Phone: (918) 587-4630 FAX: (918) 587-4630	Job 100736.010.01.0001 - TRURO, MA (BU# 841273)	Page 29 of 39
	Project	Date 14:41:12 09/21/22
	Client Crown Castle	Designed by Nithish Acharya

Location	Condition	Gov. Load Comb.	Vertical K	Horizontal, X K	Horizontal, Z K
----------	-----------	-----------------	------------	-----------------	-----------------

Tower Mast Reaction Summary

Load Combination	Vertical K	Shear _x K	Shear _z K	Overtuning Moment, M _x kip-ft	Overtuning Moment, M _z kip-ft	Torque kip-ft
Dead Only	98.125	0.000	-0.000	27.928	14.239	0.000
1.2 Dead+1.0 Wind 0 deg - No Ice	117.750	-0.048	-122.857	-11366.298	1.344	-69.525
0.9 Dead+1.0 Wind 0 deg - No Ice	88.312	-0.048	-122.857	-11374.677	-2.928	-69.525
1.2 Dead+1.0 Wind 30 deg - No Ice	117.750	56.228	-97.296	-9206.537	-5361.232	-30.929
0.9 Dead+1.0 Wind 30 deg - No Ice	88.312	56.228	-97.296	-9214.916	-5365.504	-30.929
1.2 Dead+1.0 Wind 60 deg - No Ice	117.750	92.797	-52.862	-5037.581	-8928.626	0.161
0.9 Dead+1.0 Wind 60 deg - No Ice	88.312	92.797	-52.862	-5045.959	-8932.898	0.161
1.2 Dead+1.0 Wind 90 deg - No Ice	117.750	108.734	0.357	56.593	-10426.792	20.825
0.9 Dead+1.0 Wind 90 deg - No Ice	88.312	108.734	0.357	48.214	-10431.064	20.825
1.2 Dead+1.0 Wind 120 deg - No Ice	117.750	103.366	59.295	5566.687	-9703.021	58.108
0.9 Dead+1.0 Wind 120 deg - No Ice	88.312	103.366	59.295	5558.309	-9707.292	58.108
1.2 Dead+1.0 Wind 150 deg - No Ice	117.750	60.269	102.984	9597.088	-5618.070	75.271
0.9 Dead+1.0 Wind 150 deg - No Ice	88.312	60.269	102.984	9588.710	-5622.342	75.271
1.2 Dead+1.0 Wind 180 deg - No Ice	117.750	0.447	115.984	10877.855	-20.550	68.809
0.9 Dead+1.0 Wind 180 deg - No Ice	88.312	0.447	115.984	10869.477	-24.822	68.809
1.2 Dead+1.0 Wind 210 deg - No Ice	117.750	-56.153	96.646	9192.168	5377.799	29.860
0.9 Dead+1.0 Wind 210 deg - No Ice	88.312	-56.153	96.646	9183.789	5373.527	29.860
1.2 Dead+1.0 Wind 240 deg - No Ice	117.750	-98.085	56.189	5362.233	9355.318	1.586
0.9 Dead+1.0 Wind 240 deg - No Ice	88.312	-98.085	56.189	5353.854	9351.046	1.586
1.2 Dead+1.0 Wind 270 deg - No Ice	117.750	-108.205	-0.363	8.446	10393.527	-20.211
0.9 Dead+1.0 Wind 270 deg - No Ice	88.312	-108.205	-0.363	0.068	10389.255	-20.211
1.2 Dead+1.0 Wind 300 deg - No Ice	117.750	-97.217	-55.893	-5224.520	9226.630	-57.250
0.9 Dead+1.0 Wind 300 deg - No Ice	88.312	-97.217	-55.893	-5232.899	9222.358	-57.250
1.2 Dead+1.0 Wind 330 deg - No Ice	117.750	-59.904	-103.030	-9537.875	5598.403	-75.227
0.9 Dead+1.0 Wind 330 deg - No Ice	88.312	-59.904	-103.030	-9546.253	5594.131	-75.227
1.2 Dead+1.0 Ice+1.0 Temp	268.053	0.000	-0.000	85.620	40.282	0.000
1.2 Dead+1.0 Wind 0 deg+1.0	268.053	0.171	-24.521	-2242.939	23.270	-7.083

tnxTower B+T Group 1717 S, Boulder, Suite 300 Tulsa, OK 74119 Phone: (918) 587-4630 FAX: (918) 587-4630	Job 100736.010.01.0001 - TRURO, MA (BU# 841273)	Page 30 of 39
	Project	Date 14:41:12 09/21/22
	Client Crown Castle	Designed by Nithish Acharya

Load Combination	Vertical K	Shear _x K	Shear _z K	Overturning Moment, M _x kip-ft	Overturning Moment, M _z kip-ft	Torque kip-ft
Ice+1.0 Temp						
1.2 Dead+1.0 Wind 30 deg+1.0	268.053	11.662	-19.947	-1841.807	-1090.507	-2.193
Ice+1.0 Temp						
1.2 Dead+1.0 Wind 60 deg+1.0	268.053	19.312	-11.040	-991.095	-1849.575	0.562
Ice+1.0 Temp						
1.2 Dead+1.0 Wind 90 deg+1.0	268.053	22.680	-0.058	79.919	-2163.256	-0.435
Ice+1.0 Temp						
1.2 Dead+1.0 Wind 120 deg+1.0	268.053	21.004	11.859	1214.154	-1965.282	1.990
Ice+1.0 Temp						
1.2 Dead+1.0 Wind 150 deg+1.0	268.053	12.208	20.911	2068.282	-1122.363	7.097
Ice+1.0 Temp						
1.2 Dead+1.0 Wind 180 deg+1.0	268.053	0.057	23.771	2353.905	35.102	7.550
Ice+1.0 Temp						
1.2 Dead+1.0 Wind 210 deg+1.0	268.053	-11.507	19.866	2002.845	1156.230	2.991
Ice+1.0 Temp						
1.2 Dead+1.0 Wind 240 deg+1.0	268.053	-19.744	11.330	1183.730	1959.540	-0.284
Ice+1.0 Temp						
1.2 Dead+1.0 Wind 270 deg+1.0	268.053	-22.540	-0.063	80.584	2228.905	-0.350
Ice+1.0 Temp						
1.2 Dead+1.0 Wind 300 deg+1.0	268.053	-20.237	-11.646	-1026.845	1981.922	-2.457
Ice+1.0 Temp						
1.2 Dead+1.0 Wind 330 deg+1.0	268.053	-12.146	-20.925	-1898.761	1194.869	-7.089
Ice+1.0 Temp						
Dead+Wind 0 deg - Service	98.125	-0.008	-20.174	-1849.642	11.687	-11.274
Dead+Wind 30 deg - Service	98.125	9.244	-15.995	-1495.536	-872.398	-5.021
Dead+Wind 60 deg - Service	98.125	15.265	-8.698	-808.892	-1461.496	0.015
Dead+Wind 90 deg - Service	98.125	17.884	0.058	31.670	-1708.321	3.364
Dead+Wind 120 deg - Service	98.125	16.979	9.741	939.676	-1587.068	9.412
Dead+Wind 150 deg - Service	98.125	9.899	16.917	1603.853	-914.046	12.199
Dead+Wind 180 deg - Service	98.125	0.072	19.059	1815.425	8.136	11.158
Dead+Wind 210 deg - Service	98.125	-9.231	15.890	1538.193	898.022	4.848
Dead+Wind 240 deg - Service	98.125	-16.123	9.237	906.523	1553.624	0.268
Dead+Wind 270 deg - Service	98.125	-17.798	-0.059	23.863	1725.864	-3.265
Dead+Wind 300 deg - Service	98.125	-15.982	-9.189	-839.205	1532.756	-9.273
Dead+Wind 330 deg - Service	98.125	-9.840	-16.925	-1549.264	933.794	-12.192

Solution Summary

Load Comb.	Sum of Applied Forces			Sum of Reactions			% Error
	PX K	PY K	PZ K	PX K	PY K	PZ K	
1	0.000	-98.125	0.000	-0.000	98.125	0.000	0.000%
2	-0.048	-117.750	-122.857	0.048	117.750	122.857	0.000%
3	-0.048	-88.312	-122.857	0.048	88.312	122.857	0.000%
4	56.228	-117.750	-97.296	-56.228	117.750	97.296	0.000%
5	56.228	-88.312	-97.296	-56.228	88.312	97.296	0.000%
6	92.797	-117.750	-52.862	-92.797	117.750	52.862	0.000%
7	92.797	-88.312	-52.862	-92.797	88.312	52.862	0.000%
8	108.734	-117.750	0.357	-108.734	117.750	-0.357	0.000%
9	108.734	-88.312	0.357	-108.734	88.312	-0.357	0.000%
10	103.366	-117.750	59.295	-103.366	117.750	-59.295	0.000%
11	103.366	-88.312	59.295	-103.366	88.312	-59.295	0.000%
12	60.269	-117.750	102.984	-60.269	117.750	-102.984	0.000%
13	60.269	-88.312	102.984	-60.269	88.312	-102.984	0.000%
14	0.447	-117.750	115.984	-0.447	117.750	-115.984	0.000%
15	0.447	-88.312	115.984	-0.447	88.312	-115.984	0.000%
16	-56.153	-117.750	96.646	56.153	117.750	-96.646	0.000%
17	-56.153	-88.312	96.646	56.153	88.312	-96.646	0.000%

tnxTower B+T Group 1717 S, Boulder, Suite 300 Tulsa, OK 74119 Phone: (918) 587-4630 FAX: (918) 587-4630	Job	100736.010.01.0001 - TRURO, MA (BU# 841273)	Page	31 of 39
	Project		Date	14:41:12 09/21/22
	Client	Crown Castle		Designed by

Load Comb.	Sum of Applied Forces			Sum of Reactions			% Error
	PX K	PY K	PZ K	PX K	PY K	PZ K	
18	-98.085	-117.750	56.189	98.085	117.750	-56.189	0.000%
19	-98.085	-88.312	56.189	98.085	88.312	-56.189	0.000%
20	-108.205	-117.750	-0.363	108.205	117.750	0.363	0.000%
21	-108.205	-88.312	-0.363	108.205	88.312	0.363	0.000%
22	-97.217	-117.750	-55.893	97.217	117.750	55.893	0.000%
23	-97.217	-88.312	-55.893	97.217	88.312	55.893	0.000%
24	-59.904	-117.750	-103.030	59.904	117.750	103.030	0.000%
25	-59.904	-88.312	-103.030	59.904	88.312	103.030	0.000%
26	0.000	-268.053	0.000	-0.000	268.053	0.000	0.000%
27	0.171	-268.053	-24.521	-0.171	268.053	24.521	0.000%
28	11.662	-268.053	-19.947	-11.662	268.053	19.947	0.000%
29	19.312	-268.053	-11.040	-19.312	268.053	11.040	0.000%
30	22.680	-268.053	-0.058	-22.680	268.053	0.058	0.000%
31	21.004	-268.053	11.859	-21.004	268.053	-11.859	0.000%
32	12.208	-268.053	20.911	-12.208	268.053	-20.911	0.000%
33	0.057	-268.053	23.771	-0.057	268.053	-23.771	0.000%
34	-11.507	-268.053	19.866	11.507	268.053	-19.866	0.000%
35	-19.744	-268.053	11.330	19.744	268.053	-11.330	0.000%
36	-22.540	-268.053	-0.063	22.540	268.053	0.063	0.000%
37	-20.237	-268.053	-11.646	20.237	268.053	11.646	0.000%
38	-12.146	-268.053	-20.925	12.146	268.053	20.925	0.000%
39	-0.008	-98.125	-20.174	0.008	98.125	20.174	0.000%
40	9.244	-98.125	-15.995	-9.244	98.125	15.995	0.000%
41	15.265	-98.125	-8.698	-15.265	98.125	8.698	0.000%
42	17.884	-98.125	0.058	-17.884	98.125	-0.058	0.000%
43	16.979	-98.125	9.741	-16.979	98.125	-9.741	0.000%
44	9.899	-98.125	16.917	-9.899	98.125	-16.917	0.000%
45	0.072	-98.125	19.059	-0.072	98.125	-19.059	0.000%
46	-9.231	-98.125	15.890	9.231	98.125	-15.890	0.000%
47	-16.123	-98.125	9.237	16.123	98.125	-9.237	0.000%
48	-17.798	-98.125	-0.059	17.798	98.125	0.059	0.000%
49	-15.982	-98.125	-9.189	15.982	98.125	9.189	0.000%
50	-9.840	-98.125	-16.925	9.840	98.125	16.925	0.000%

Maximum Tower Deflections - Service Wind

Section No.	Elevation ft	Horz. Deflection in	Gov. Load Comb.	Tilt °	Twist °
T1	170 - 160	1.262	43	0.060	0.014
T2	160 - 140	1.137	43	0.059	0.013
T3	140 - 120	0.894	43	0.054	0.010
T4	120 - 100	0.669	43	0.047	0.007
T5	100 - 80	0.474	39	0.039	0.005
T6	80 - 60	0.314	39	0.031	0.004
T7	60 - 40	0.190	39	0.023	0.003
T8	40 - 20	0.098	39	0.015	0.002
T9	20 - 0	0.036	39	0.008	0.001

Critical Deflections and Radius of Curvature - Service Wind

tnxTower B+T Group 1717 S, Boulder, Suite 300 Tulsa, OK 74119 Phone: (918) 587-4630 FAX: (918) 587-4630	Job 100736.010.01.0001 - TRURO, MA (BU# 841273)	Page 32 of 39
	Project	Date 14:41:12 09/21/22
	Client Crown Castle	Designed by Nithish Acharya

Elevation	Appurtenance	Gov. Load Comb.	Deflection in	Tilt °	Twist °	Radius of Curvature ft
170'	Lightning Rod 5/8" x 5'	43	1.262	0.060	0.014	972466
168'	AIR 6419 B41 TMO	43	1.237	0.060	0.014	972466
160'	6813-2 HW	43	1.137	0.059	0.013	503337
151'	(2) P65.15.XL.0 w/ Mount Pipe	43	1.026	0.057	0.012	317238
145'	800 10122 w/ Mount Pipe	43	0.953	0.055	0.011	257561
139'	Pipe Mount [PM 601-1]	43	0.882	0.054	0.010	219284
138'	Andrew PAR6-59A	43	0.870	0.053	0.010	214674
130'	LNx-6514DS-A1M w/ Mount Pipe	43	0.778	0.050	0.008	183411
122'	MX08FRO665-21 w/ Mount Pipe	43	0.690	0.047	0.007	160396
106'	COMMSCOPE VHLPX4-11W-6WH	43	0.529	0.041	0.006	138060
104'	ANT150F2	43	0.510	0.041	0.006	135911
96'	ERICSSON AIR 21 B4A B2P	39	0.439	0.038	0.005	131023
87'	PR-950	39	0.366	0.034	0.004	129309
71'	GPS-TMG-HR-26N	39	0.254	0.027	0.004	136689

Maximum Tower Deflections - Design Wind

Section No.	Elevation ft	Horz. Deflection in	Gov. Load Comb.	Tilt °	Twist °
T1	170 - 160	7.690	3	0.356	0.084
T2	160 - 140	6.933	3	0.351	0.083
T3	140 - 120	5.462	3	0.325	0.062
T4	120 - 100	4.101	3	0.283	0.044
T5	100 - 80	2.910	3	0.239	0.032
T6	80 - 60	1.928	3	0.190	0.025
T7	60 - 40	1.166	3	0.138	0.019
T8	40 - 20	0.600	3	0.092	0.013
T9	20 - 0	0.217	2	0.046	0.008

Critical Deflections and Radius of Curvature - Design Wind

Elevation	Appurtenance	Gov. Load Comb.	Deflection in	Tilt °	Twist °	Radius of Curvature ft
170'	Lightning Rod 5/8" x 5'	3	7.690	0.356	0.084	172147
168'	AIR 6419 B41 TMO	3	7.538	0.355	0.084	172147
160'	6813-2 HW	3	6.933	0.351	0.083	89745
151'	(2) P65.15.XL.0 w/ Mount Pipe	3	6.261	0.342	0.075	58010
145'	800 10122 w/ Mount Pipe	3	5.822	0.333	0.068	46587
139'	Pipe Mount [PM 601-1]	3	5.391	0.323	0.061	39022
138'	Andrew PAR6-59A	3	5.320	0.321	0.060	38027
130'	LNx-6514DS-A1M w/ Mount Pipe	3	4.764	0.305	0.052	31670
122'	MX08FRO665-21 w/ Mount Pipe	3	4.231	0.288	0.046	27181
106'	COMMSCOPE VHLPX4-11W-6WH	3	3.246	0.253	0.035	23235
104'	ANT150F2	3	3.132	0.248	0.034	22865
96'	ERICSSON AIR 21 B4A B2P	3	2.696	0.229	0.031	21893
87'	PR-950	3	2.246	0.207	0.027	21466
71'	GPS-TMG-HR-26N	3	1.559	0.166	0.022	22622

tnxTower B+T Group 1717 S, Boulder, Suite 300 Tulsa, OK 74119 Phone: (918) 587-4630 FAX: (918) 587-4630	Job 100736.010.01.0001 - TRURO, MA (BU# 841273)	Page 33 of 39
	Project	Date 14:41:12 09/21/22
	Client Crown Castle	Designed by Nithish Acharya

Bolt Design Data

Section No.	Elevation ft	Component Type	Bolt Grade	Bolt Size in	Number Of Bolts	Maximum Load per Bolt K	Allowable Load per Bolt K	Ratio		Allowable Ratio	Criteria
								Load	Allowable		
T1	170	Leg	A325N	1.000	4	1.075	54.517	0.020	✓	1.05	Bolt Tension
		Diagonal	A325N	0.625	1	3.354	13.806	0.243	✓	1.05	Bolt Shear
		Top Girt	A325N	0.625	1	0.248	9.914	0.025	✓	1.05	Member Block Shear
T2	160	Leg	A325N	1.250	4	7.754	87.220	0.089	✓	1.05	Bolt Tension
		Diagonal	A325N	0.750	1	8.793	18.922	0.465	✓	1.05	Gusset Bearing
T3	140	Leg	A325N	1.250	6	12.649	87.220	0.145	✓	1.05	Bolt Tension
		Diagonal	A325N	1.000	1	12.756	20.227	0.631	✓	1.05	Member Bearing
T4	120	Leg	A325N	1.375	6	21.808	103.939	0.210	✓	1.05	Bolt Tension
		Diagonal	A325N	1.000	1	15.516	26.970	0.575	✓	1.05	Member Bearing
T5	100	Leg	A325N	1.375	6	32.126	103.939	0.309	✓	1.05	Bolt Tension
		Diagonal	A325N	1.125	1	20.943	26.100	0.802	✓	1.05	Member Bearing
T6	80	Leg	A325N	1.500	6	43.557	126.472	0.344	✓	1.05	Bolt Tension
		Diagonal	A325N	1.125	1	22.278	32.625	0.683	✓	1.05	Member Bearing
T7	60	Leg	A325N	1.500	8	41.044	126.472	0.325	✓	1.05	Bolt Tension
		Diagonal	A325N	1.250	1	23.547	31.538	0.747	✓	1.05	Member Bearing
T8	40	Leg	A325N	1.500	8	49.202	126.472	0.389	✓	1.05	Bolt Tension
		Diagonal	A325N	1.250	1	25.317	31.538	0.803	✓	1.05	Member Bearing
T9	20	Diagonal	A325N	1.000	2	17.426	35.343	0.493	✓	1.05	Bolt Shear
		Horizontal	A325N	1.000	2	12.001	26.916	0.446	✓	1.05	Member Block Shear
		Redund Horiz 1 Bracing	A325N	1.000	1	9.076	14.953	0.607	✓	1.05	Member Block Shear
		Redund Diag 1 Bracing	A325N	1.000	1	5.867	11.963	0.490	✓	1.05	Member Block Shear

Compression Checks

Leg Design Data (Compression)

Section No.	Elevation ft	Size	L ft	L _u ft	Kl/r	A in ²	P _u K	φP _n K	Ratio
									$\frac{P_u}{\phi P_n}$
T1	170 - 160	Sabre 3.5" x 0.216"	10'7/32"	5'3/32"	51.7 K=1.00	2.228	-7.736	82.510	0.094 ¹ ✓
T2	160 - 140	Sabre 4.5" x 0.438"	20'13/32"	6'8-1/8"	55.5 K=1.00	5.589	-40.935	200.839	0.204 ¹ ✓

tnxTower B+T Group 1717 S, Boulder, Suite 300 Tulsa, OK 74119 Phone: (918) 587-4630 FAX: (918) 587-4630	Job 100736.010.01.0001 - TRURO, MA (BU# 841273)	Page 34 of 39
	Project	Date 14:41:12 09/21/22
	Client Crown Castle	Designed by Nithish Acharya

Section No.	Elevation ft	Size	L ft	L _u ft	Kl/r	A in ²	P _u K	φP _n K	Ratio $\frac{P_u}{\phi P_n}$
T3	140 - 120	Sabre 6.625" x 0.432"	20'13/32"	6'8-1/8"	36.5 K=1.00	8.405	-95.003	343.100	0.277 ¹ ✓
T4	120 - 100	Sabre 8.625" x 0.5"	20'13/32"	6'8-1/8"	27.8 K=1.00	12.763	-160.765	542.674	0.296 ¹ ✓
T5	100 - 80	Sabre 10.750" x 0.500"	20'13/32"	10'7/32"	33.1 K=1.00	16.101	-231.538	668.659	0.346 ¹ ✓
T6	80 - 60	Sabre 12.75" x 0.5"	20'13/32"	10'7/32"	27.7 K=1.00	19.242	-310.146	818.560	0.379 ¹ ✓
T7	60 - 40	Sabre 16" x 0.5"	20'13/32"	10'7/32"	21.9 K=1.00	24.347	-389.310	1057.800	0.368 ¹ ✓
T8	40 - 20	Sabre 18" x 0.5"	20'13/32"	10'7/32"	19.4 K=1.00	27.489	-467.770	1203.360	0.389 ¹ ✓
T9	20 - 0	Sabre 18" x 0.5"	20'13/32"	5'3/32"	9.7 K=1.00	27.489	-523.334	1228.500	0.426 ¹ ✓

¹ P_u / φP_n controls

Diagonal Design Data (Compression)

Section No.	Elevation ft	Size	L ft	L _u ft	Kl/r	A in ²	P _u K	φP _n K	Ratio $\frac{P_u}{\phi P_n}$
T1	170 - 160	L2x2x3/8	10'15/16"	4'10-7/16"	150.2 K=1.00	1.360	-3.354	17.250	0.194 ¹ ✓
T2	160 - 140	L3x3x3/8	12'6-31/32"	6'1-7/16"	125.1 K=1.00	2.110	-8.889	38.577	0.230 ¹ ✓
T3	140 - 120	L3 1/2x3 1/2x3/8	14'3-25/32"	6'10-13/32"	120.0 K=1.00	2.480	-12.897	48.877	0.264 ¹ ✓
T4	120 - 100	L3 1/2x3 1/2x1/2	16'1-11/32"	7'8-1/8"	134.9 K=1.00	3.250	-15.693	51.122	0.307 ¹ ✓
T5	100 - 80	L5x5x1/2	19'3-9/16"	9'2-13/16"	114.5 K=1.02	4.750	-21.079	100.449	0.210 ¹ ✓
T6	80 - 60	L5x5x5/8	21'3/8"	10'5/32"	122.9 K=1.00	5.860	-22.481	110.813	0.203 ¹ ✓
T7	60 - 40	L5x5x5/8	22'9-23/32"	10'8-15/16"	131.8 K=1.00	5.860	-24.079	96.513	0.249 ¹ ✓
T8	40 - 20	L5x5x5/8	24'7-1/2"	11'6-13/16"	141.9 K=1.00	5.860	-26.567	83.268	0.319 ¹ ✓
T9	20 - 0	L5x5x5/8	16'1/8"	15'19/32"	118.8 K=1.00	5.860	-34.851	117.313	0.297 ¹ ✓

¹ P_u / φP_n controls

Horizontal Design Data (Compression)

tnxTower B+T Group 1717 S, Boulder, Suite 300 Tulsa, OK 74119 Phone: (918) 587-4630 FAX: (918) 587-4630	Job 100736.010.01.0001 - TRURO, MA (BU# 841273)	Page 35 of 39
	Project	Date 14:41:12 09/21/22
	Client Crown Castle	Designed by Nithish Acharya

Section No.	Elevation ft	Size	L ft	L _u ft	Kl/r	A in ²	P _u K	φP _n K	Ratio $\frac{P_u}{\phi P_n}$
T9	20 - 0	2L3 1/2x3 1/2x1/4x3/8	24'	11'3"	155.5 K=1.00	3.380	-25.174	38.299	0.657 ¹ ✓
2L 'a' > 64.466 in - 159									

¹ P_u / φP_n controls

Top Girt Design Data (Compression)

Section No.	Elevation ft	Size	L ft	L _u ft	Kl/r	A in ²	P _u K	φP _n K	Ratio $\frac{P_u}{\phi P_n}$
T1	170 - 160	L2 1/2x2 1/2x3/16	8'	7'5"	179.8 K=1.00	0.902	-0.291	7.986	0.036 ¹ ✓

¹ P_u / φP_n controls

Redundant Horizontal (1) Design Data (Compression)

Section No.	Elevation ft	Size	L ft	L _u ft	Kl/r	A in ²	P _u K	φP _n K	Ratio $\frac{P_u}{\phi P_n}$
T9	20 - 0	L3x3x5/16	6'	5'3"	107.0 K=1.00	1.780	-9.076	41.028	0.221 ¹ ✓

¹ P_u / φP_n controls

Redundant Diagonal (1) Design Data (Compression)

Section No.	Elevation ft	Size	L ft	L _u ft	Kl/r	A in ²	P _u K	φP _n K	Ratio $\frac{P_u}{\phi P_n}$
T9	20 - 0	L3x3x1/4	7'7-7/16'	6'7-17/32"	134.3 K=1.00	1.440	-5.764	22.837	0.252 ¹ ✓

¹ P_u / φP_n controls

Inner Bracing Design Data (Compression)

Section No.	Elevation ft	Size	L ft	L _u ft	Kl/r	A in ²	P _u K	φP _n K	Ratio $\frac{P_u}{\phi P_n}$
-------------	-----------------	------	---------	----------------------	------	----------------------	---------------------	----------------------	---------------------------------

tnxTower B+T Group 1717 S, Boulder, Suite 300 Tulsa, OK 74119 Phone: (918) 587-4630 FAX: (918) 587-4630	Job 100736.010.01.0001 - TRURO, MA (BU# 841273)	Page 36 of 39
	Project	Date 14:41:12 09/21/22
	Client Crown Castle	Designed by Nithish Acharya

Section No.	Elevation ft	Size	L ft	L _u ft	Kl/r	A in ²	P _u K	φP _n K	Ratio $\frac{P_u}{\phi P_n}$
T9	20 - 0	L3x3x3/16	12'	12'	241.6 K=1.00	1.090	-0.034	5.344	0.006 ¹ ✓

¹ P_u / φP_n controls

Tension Checks

Leg Design Data (Tension)

Section No.	Elevation ft	Size	L ft	L _u ft	Kl/r	A in ²	P _u K	φP _n K	Ratio $\frac{P_u}{\phi P_n}$
T1	170 - 160	Sabre 3.5" x 0.216"	10'7/32"	5'3/32"	51.7	2.228	4.300	100.281	0.043 ¹ ✓
T2	160 - 140	Sabre 4.5" x 0.438"	20'13/32"	6'8-1/8"	55.5	5.589	31.017	251.522	0.123 ¹ ✓
T3	140 - 120	Sabre 6.625" x 0.432"	20'13/32"	6'8-1/8"	36.5	8.405	75.895	378.222	0.201 ¹ ✓
T4	120 - 100	Sabre 8.625" x 0.5"	20'13/32"	6'8-1/8"	27.8	12.763	130.846	574.322	0.228 ¹ ✓
T5	100 - 80	Sabre 10.750" x 0.500"	20'13/32"	10'7/32"	33.1	16.101	192.757	724.530	0.266 ¹ ✓
T6	80 - 60	Sabre 12.75" x 0.5"	20'13/32"	10'7/32"	27.7	19.242	261.343	865.902	0.302 ¹ ✓
T7	60 - 40	Sabre 16" x 0.5"	20'13/32"	10'7/32"	21.9	24.347	328.352	1095.630	0.300 ¹ ✓
T8	40 - 20	Sabre 18" x 0.5"	20'13/32"	10'7/32"	19.4	27.489	393.616	1237.000	0.318 ¹ ✓
T9	20 - 0	Sabre 18" x 0.5"	20'13/32"	5'3/32"	9.7	27.489	438.312	1237.000	0.354 ¹ ✓

¹ P_u / φP_n controls

Diagonal Design Data (Tension)

Section No.	Elevation ft	Size	L ft	L _u ft	Kl/r	A in ²	P _u K	φP _n K	Ratio $\frac{P_u}{\phi P_n}$
T1	170 - 160	L2x2x3/8	10'15/16"	4'10-7/16"	101.3	0.809	3.333	35.194	0.095 ¹ ✓
T2	160 - 140	L3x3x3/8	12'6-31/32"	6'1-7/16"	82.4	1.336	8.793	58.134	0.151 ¹ ✓
T3	140 - 120	L3 1/2x3 1/2x3/8	14'3-25/32"	6'10-13/32"	78.9	1.544	12.756	67.146	0.190 ¹ ✓
T4	120 - 100	L3 1/2x3 1/2x1/2	16'1-11/16"	7'8-1/8"	88.8	2.016	15.516	87.680	0.177 ¹ ✓

tnxTower B+T Group 1717 S, Boulder, Suite 300 Tulsa, OK 74119 Phone: (918) 587-4630 FAX: (918) 587-4630	Job	100736.010.01.0001 - TRURO, MA (BU# 841273)	Page	37 of 39
	Project		Date	14:41:12 09/21/22
	Client	Crown Castle		Designed by

Section No.	Elevation ft	Size	L ft	L _u ft	Kl/r	A in ²	P _u K	φP _n K	Ratio $\frac{P_u}{\phi P_n}$
T5	100 - 80	L5x5x1/2	19'3-9/16"	9'2-13/16"	73.4	3.094	20.943	134.578	0.156 ¹ ✓
T6	80 - 60	L5x5x5/8	21'3/8"	10'5/32"	80.5	3.809	22.278	165.694	0.134 ¹ ✓
T7	60 - 40	L5x5x5/8	22'9-23/32"	10'8-15/16"	86.4	3.750	23.547	163.145	0.144 ¹ ✓
T8	40 - 20	L5x5x5/8	24'7-1/2'	11'6-13/16"	92.9	3.750	25.317	163.145	0.155 ¹ ✓
T9	20 - 0	L5x5x5/8	16'1/8"	15'19/32"	118.8	3.868	31.906	168.243	0.190 ¹ ✓

¹ P_u / φP_n controls

Horizontal Design Data (Tension)

Section No.	Elevation ft	Size	L ft	L _u ft	Kl/r	A in ²	P _u K	φP _n K	Ratio $\frac{P_u}{\phi P_n}$
T9	20 - 0	2L3 1/2x3 1/2x1/4x3/8	23'	10'9"	118.3	2.113	24.002	91.921	0.261 ¹ ✓
2L 'a' > 61.600 in - 183									

¹ P_u / φP_n controls

Top Girt Design Data (Tension)

Section No.	Elevation ft	Size	L ft	L _u ft	Kl/r	A in ²	P _u K	φP _n K	Ratio $\frac{P_u}{\phi P_n}$
T1	170 - 160	L2 1/2x2 1/2x3/16	8'	7'5"	118.9	0.571	0.248	24.840	0.010 ¹ ✓

¹ P_u / φP_n controls

Redundant Horizontal (1) Design Data (Tension)

Section No.	Elevation ft	Size	L ft	L _u ft	Kl/r	A in ²	P _u K	φP _n K	Ratio $\frac{P_u}{\phi P_n}$
T9	20 - 0	L3x3x5/16	6'	5'3"	68.3	1.071	9.076	46.603	0.195 ¹ ✓

tnxTower B+T Group 1717 S, Boulder, Suite 300 Tulsa, OK 74119 Phone: (918) 587-4630 FAX: (918) 587-4630	Job	100736.010.01.0001 - TRURO, MA (BU# 841273)	Page	38 of 39
	Project		Date	14:41:12 09/21/22
	Client	Crown Castle		Designed by

¹ P_u / φP_n controls

Redundant Diagonal (1) Design Data (Tension)

Section No.	Elevation ft	Size	L ft	L _u ft	Kl/r	A in ²	P _u K	φP _n K	Ratio $\frac{P_u}{\phi P_n}$
T9	20 - 0	L3x3x1/4	7'5-7/32'	6'5-9/32'	83.1	0.869	5.867	37.804	0.155 ¹

¹ P_u / φP_n controls

Inner Bracing Design Data (Tension)

Section No.	Elevation ft	Size	L ft	L _u ft	Kl/r	A in ²	P _u K	φP _n K	Ratio $\frac{P_u}{\phi P_n}$
T9	20 - 0	L3x3x3/16	12'	12'	153.4	1.090	0.014	35.316	0.000 ¹

¹ P_u / φP_n controls

Section Capacity Table

Section No.	Elevation ft	Component Type	Size	Critical Element	P K	φP _{allow} K	% Capacity	Pass Fail
T1	170 - 160	Leg	Sabre 3.5" x 0.216"	1	-7.736	86.635	8.9	Pass
T2	160 - 140	Leg	Sabre 4.5" x 0.438"	19	-40.935	210.881	19.4	Pass
T3	140 - 120	Leg	Sabre 6.625" x 0.432"	40	-95.003	360.255	26.4	Pass
T4	120 - 100	Leg	Sabre 8.625" x 0.5"	62	-160.765	569.808	28.2	Pass
T5	100 - 80	Leg	Sabre 10.750" x 0.500"	83	-231.538	702.092	33.0	Pass
T6	80 - 60	Leg	Sabre 12.75" x 0.5"	99	-310.146	859.488	36.1	Pass
T7	60 - 40	Leg	Sabre 16" x 0.5"	114	-389.310	1110.690	35.1	Pass
T8	40 - 20	Leg	Sabre 18" x 0.5"	129	-467.770	1263.528	37.0	Pass
T9	20 - 0	Leg	Sabre 18" x 0.5"	144	-523.334	1289.925	40.6	Pass
T1	170 - 160	Diagonal	L2x2x3/8	12	-3.354	18.112	18.5	Pass
T2	160 - 140	Diagonal	L3x3x3/8	22	-8.889	40.506	21.9	Pass
T3	140 - 120	Diagonal	L3 1/2x3 1/2x3/8	44	-12.897	51.321	25.1	Pass
T4	120 - 100	Diagonal	L3 1/2x3 1/2x1/2	68	-15.693	53.678	29.2	Pass
T5	100 - 80	Diagonal	L5x5x1/2	89	-21.079	105.471	20.0	Pass
T6	80 - 60	Diagonal	L5x5x5/8	104	-22.481	116.354	19.3	Pass
T7	60 - 40	Diagonal	L5x5x5/8	119	-24.079	101.338	23.8	Pass
T8	40 - 20	Diagonal	L5x5x5/8	134	-26.567	87.432	30.4	Pass
T9	20 - 0	Diagonal	L5x5x5/8	160	-34.851	123.179	28.3	Pass
T9	20 - 0	Horizontal	2L3 1/2x3 1/2x1/4x3/8	159	-25.174	40.214	62.6	Pass
T1	170 - 160	Top Girt	L2 1/2x2 1/2x3/16	4	-0.291	8.385	3.5	Pass
T9	20 - 0	Redund Horz 1 Bracing	L3x3x5/16	157	-9.076	43.079	21.1	Pass
T9	20 - 0	Redund Diag 1 Bracing	L3x3x1/4	158	-5.764	23.979	24.0	Pass

tnxTower B+T Group 1717 S, Boulder, Suite 300 Tulsa, OK 74119 Phone: (918) 587-4630 FAX: (918) 587-4630	Job 100736.010.01.0001 - TRURO, MA (BU# 841273)	Page 39 of 39
	Project	Date 14:41:12 09/21/22
	Client Crown Castle	Designed by Nithish Acharya

Section No.	Elevation ft	Component Type	Size	Critical Element	P K	ϕP_{allow} K	% Capacity	Pass Fail
T9	20 - 0	Inner Bracing	L3x3x3/16	166	-0.033	5.612	0.8	Pass
							Summary	
						Leg (T9)	40.6	Pass
						Diagonal (T8)	30.4	Pass
						Horizontal (T9)	62.6	Pass
						Top Girt (T1)	3.5	Pass
						Redund Horz 1	21.1	Pass
						Bracing (T9)		
						Redund Diag 1	24.0	Pass
						Bracing (T9) Inner	0.8	Pass
						Bracing (T9) Bolt Checks	76.5	Pass
						RATING =	76.5	Pass

APPENDIX B
BASE LEVEL DRAWING

(OTHER CONSIDERED EQUIPMENT)

- (1) 1-5/8" TO 160 FT LEVEL
- (1) EW52 TO 139 FT LEVEL
- (8) 3/8" TO 104 FT LEVEL
- (10) 7/8" TO 104 FT LEVEL
- (2) 1-1/4" TO 151 FT LEVEL
- (1) 1/2" TO 170 FT LEVEL

(OTHER CONSIDERED EQUIPMENT)
(1) 1-1/2" TO 122 FT LEVEL

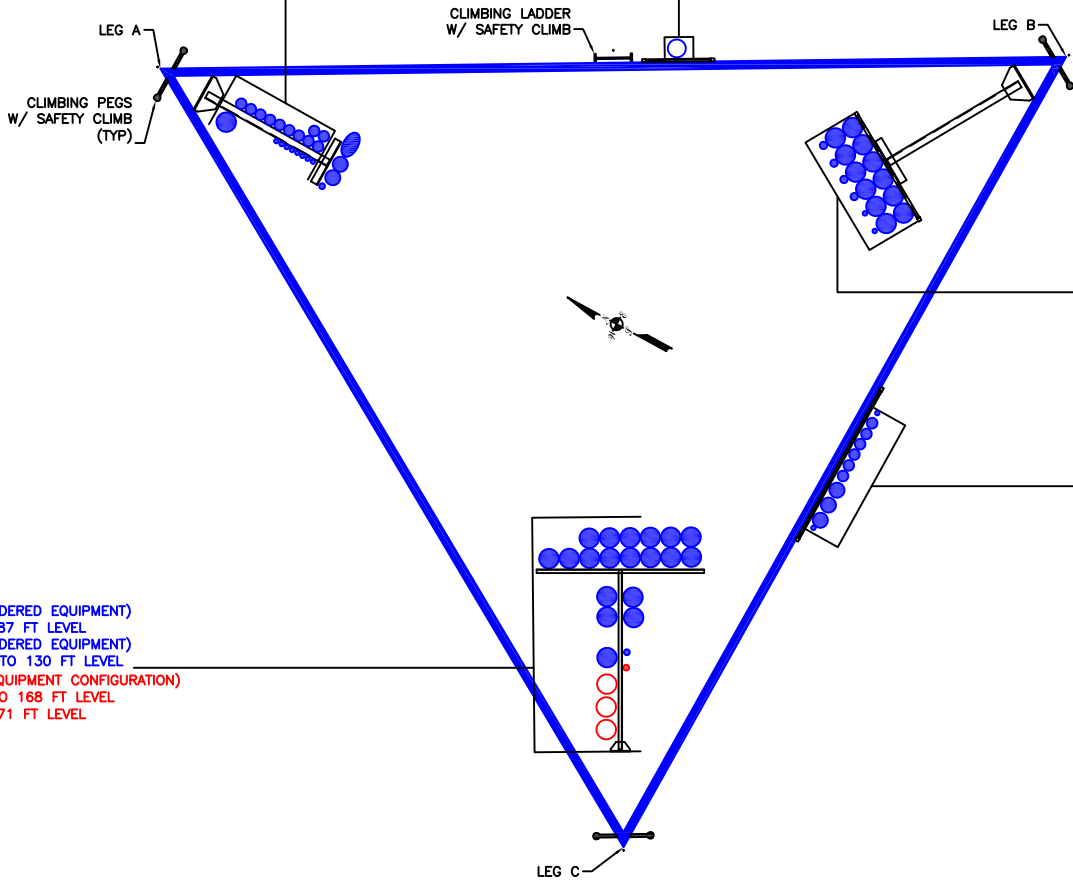

(OTHER CONSIDERED EQUIPMENT)
(2) 3/8" TO 145 FT LEVEL
(4) 5/8" TO 145 FT LEVEL
(12) 1-5/8" TO 145 FT LEVEL

(OTHER CONSIDERED EQUIPMENT)
(2) 3/8" TO 96 FT LEVEL
(6) 7/8" TO 96 FT LEVEL
(3) 1-1/4" TO 96 FT LEVEL

(OTHER CONSIDERED EQUIPMENT)

- (1) 1/2" TO 87 FT LEVEL
- (OTHER CONSIDERED EQUIPMENT)
- (19) 1-5/8" TO 130 FT LEVEL

(PROPOSED EQUIPMENT CONFIGURATION)

- (3) 1-5/8" TO 168 FT LEVEL
- (1) 1/2" TO 71 FT LEVEL

BUSINESS UNIT: 841273

APPENDIX C
ADDITIONAL CALCULATIONS

Self Support Anchor Rod Capacity



Site Info	
BU #	841273
Site Name	TRURO, MA
Order #	623577, Rev. 1

Analysis Considerations	
TIA-222 Revision	H
Grout Considered:	Yes
l_{ar} (in)	0

Applied Loads		
	Comp.	Uplift
Axial Force (kips)	564.24	472.60
Shear Force (kips)	72.30	63.05

*TIA-222-H Section 15.5 Applied

Considered Eccentricity	
Leg Mod Eccentricity (in)	0.000
Anchor Rod N.A Shift (in)	0.000
Total Eccentricity (in)	0.000

*Anchor Rod Eccentricity Applied

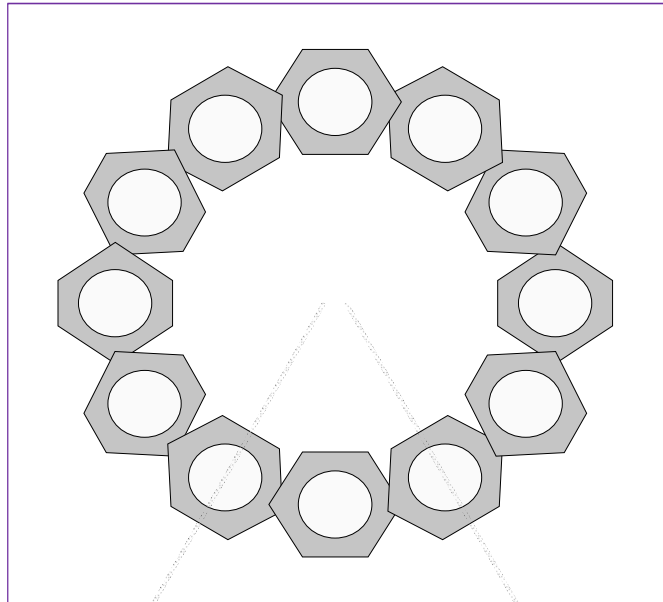

Connection Properties	Analysis Results
-----------------------	------------------

Anchor Rod Data	
(12) 2" ϕ bolts (A572-50 N; $F_y=50$ ksi, $F_u=65$ ksi)	
l_{ar} (in):	0

Anchor Rod Summary		(units of kips, kip-in)
$Pu_t = 39.38$	$\phi Pn_t = 121.88$	Stress Rating
$Vu = 5.25$	$\phi Vn = 76.58$	30.8%
$Mu = n/a$	$\phi Mn = n/a$	Pass

Drilled Pier Foundation

BU # :	841273
Site Name:	TRURO, MA
Order Number:	623577, Rev. 1
TIA-222 Revision:	H
Tower Type:	Self Support



Applied Loads		
	Comp.	Uplift
Moment (kip-ft)	0	0
Axial Force (kips)	564.24	472.6
Shear Force (kips)	72.3	63.05

Material Properties		
Concrete Strength, f'c:	3	ksi
Rebar Strength, Fy:	60	ksi
Tie Yield Strength, Fyt:	60	ksi

Pier Design Data		
Depth	41.5	ft
Ext. Above Grade	0.5	ft
Pier Section 1		
<i>From 0.5' above grade to 41.5' below grade</i>		
Pier Diameter	10	ft
Rebar Quantity	46	
Rebar Size	10	
Clear Cover to Ties	3	in
Tie Size	4	
Tie Spacing	12	in

[Rebar & Pier Options](#)

[Embedded Pole Inputs](#)

[Belled Pier Inputs](#)

Analysis Results

Soil Lateral Check	Compression	Uplift
D _{v=0} (ft from TOC)	23.12	23.12
Soil Safety Factor	39.21	44.96
Max Moment (kip-ft)	1152.22	1004.80
Rating*	3.2%	2.8%

Soil Vertical Check	Compression	Uplift
Skin Friction (kips)	1274.19	1274.19
End Bearing (kips)	294.52	-
Weight of Concrete (kips)	467.29	350.47
Total Capacity (kips)	1568.72	1624.66
Axial (kips)	1031.53	472.60
Rating*	62.6%	27.7%

Reinforced Concrete Flexure	Compression	Uplift
Critical Depth (ft from TOC)	24.05	22.18
Critical Moment (kip-ft)	1149.45	1002.32
Critical Moment Capacity	13994.23	13400.04
Rating*	7.8%	7.1%

Reinforced Concrete Shear	Compression	Uplift
Critical Depth (ft from TOC)	27.95	27.95
Critical Shear (kip)	138.84	121.07
Critical Shear Capacity	1107.51	1554.07
Rating*	11.9%	7.4%

Structural Foundation Rating*	11.9%
Soil Interaction Rating*	62.6%

*Rating per TIA-222-H Section 15.5

Check Limitation	
Apply TIA-222-H Section 15.5:	<input checked="" type="checkbox"/>
N/A	<input type="checkbox"/>
Additional Longitudinal Rebar	
Input Effective Depths (else Actual):	<input type="checkbox"/>
Shear Design Options	
Check Shear along Depth of Pier:	<input checked="" type="checkbox"/>
Utilize Shear-Friction Methodology:	<input type="checkbox"/>
Override Critical Depth:	<input type="checkbox"/>

[Go to Soil Calculations](#)

Soil Profile					
Groundwater Depth	20	# of Layers	6		

Layer	Top (ft)	Bottom (ft)	Thickness (ft)	γ _{soil} (pcf)	γ _{concrete} (pcf)	Cohesion (ksf)	Angle of Friction (degrees)	Calculated Ultimate Skin Friction Comp (ksf)	Calculated Ultimate Skin Friction Uplift (ksf)	Ultimate Skin Friction Comp Override (ksf)	Ultimate Skin Friction Uplift Override (ksf)	Ult. Gross Bearing Capacity (ksf)	SPT Blow Count	Soil Type
1	0	5	5	120	150	0	0	0.000	0.000	0.00	0.00			Cohesionless
2	5	20	15	120	150	0	32	0.000	0.000	2.15	2.15			Cohesionless
3	20	23.5	3.5	60	87.6	0	32	0.000	0.000	2.21	2.21			Cohesionless
4	23.5	28.5	5	60	87.6	0	62	0.000	0.000	2.27	2.27			Cohesionless
5	28.5	31	2.5	60	87.6	2	0	1.100	1.100	1.10	1.10			Cohesive
6	31	41.5	10.5	60	87.6	0	33	0.000	0.000	0.00	0.00	5		Cohesionless



ASCE 7 Hazards Report

Address:
No Address at This
Location

Standard: ASCE/SEI 7-10
Risk Category: III
Soil Class: D - Stiff Soil

Elevation: 0 ft (NAVD 88)
Latitude: 42.021667
Longitude: -70.075

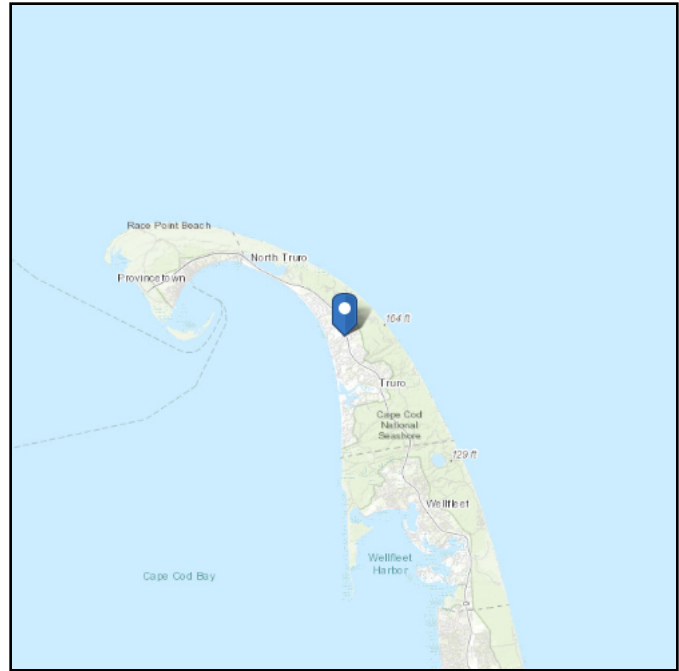
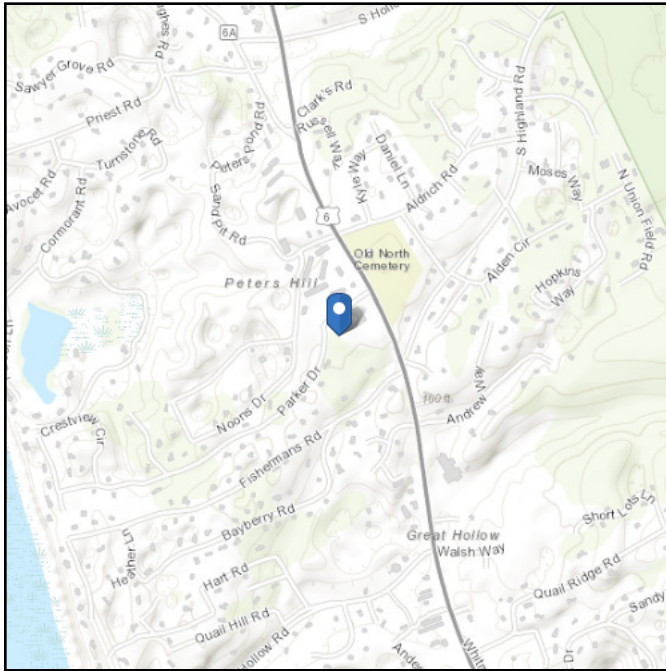

Site Soil Class: D - Stiff Soil

Results:

S_s :	0.168	S_{DS} :	0.179
S_1 :	0.058	S_{D1} :	0.093
F_a :	1.6	T_L :	6
F_v :	2.4	PGA :	0.087
S_{MS} :	0.268	PGA _M :	0.14
S_{M1} :	0.139	F _{PGA} :	1.6
		I_e :	1.25

Seismic Design Category B

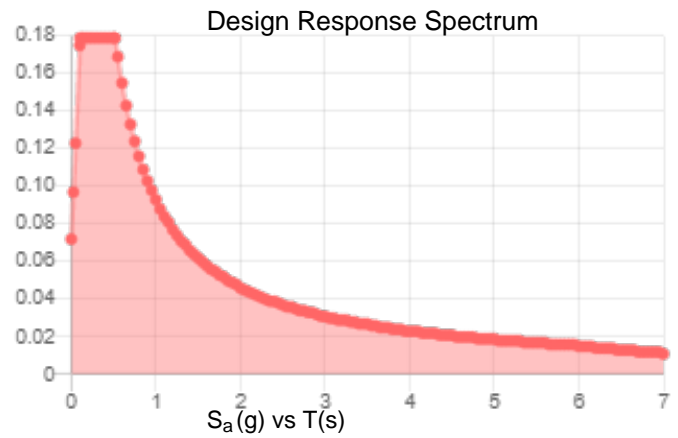
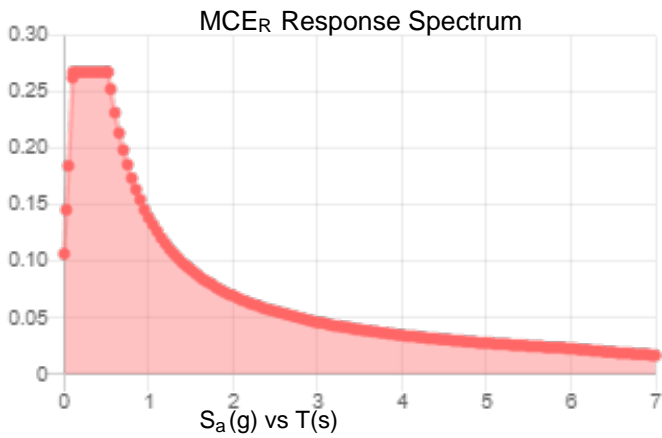

Data Accessed: Tue Sep 20 2022

Date Source:

USGS Seismic Design Maps based on ASCE/SEI 7-10, incorporating Supplement 1 and errata of March 31, 2013, and ASCE/SEI 7-10 Table 1.5-2. Additional data for site-specific ground motion procedures in accordance with ASCE/SEI 7-10 Ch. 21 are available from USGS.

Ice

Results:

Ice Thickness: 0.75 in.
Concurrent Temperature: 15 F
Gust Speed 50 mph

Data Source: Standard ASCE/SEI 7-10, Figs. 10-2 through 10-8

Date Accessed: Tue Sep 20 2022

Ice thicknesses on structures in exposed locations at elevations higher than the surrounding terrain and in valleys and gorges may exceed the mapped values.

Values provided are equivalent radial ice thicknesses due to freezing rain with concurrent 3-second gust speeds, for a 50-year mean recurrence interval, and temperatures concurrent with ice thicknesses due to freezing rain. Thicknesses for ice accretions caused by other sources shall be obtained from local meteorological studies. Ice thicknesses in exposed locations at elevations higher than the surrounding terrain and in valleys and gorges may exceed the mapped values.

The ASCE 7 Hazard Tool is provided for your convenience, for informational purposes only, and is provided “as is” and without warranties of any kind. The location data included herein has been obtained from information developed, produced, and maintained by third party providers; or has been extrapolated from maps incorporated in the ASCE 7 standard. While ASCE has made every effort to use data obtained from reliable sources or methodologies, ASCE does not make any representations or warranties as to the accuracy, completeness, reliability, currency, or quality of any data provided herein. Any third-party links provided by this Tool should not be construed as an endorsement, affiliation, relationship, or sponsorship of such third-party content by or from ASCE.

ASCE does not intend, nor should anyone interpret, the results provided by this Tool to replace the sound judgment of a competent professional, having knowledge and experience in the appropriate field(s) of practice, nor to substitute for the standard of care required of such professionals in interpreting and applying the contents of this Tool or the ASCE 7 standard.

In using this Tool, you expressly assume all risks associated with your use. Under no circumstances shall ASCE or its officers, directors, employees, members, affiliates, or agents be liable to you or any other person for any direct, indirect, special, incidental, or consequential damages arising from or related to your use of, or reliance on, the Tool or any information obtained therein. To the fullest extent permitted by law, you agree to release and hold harmless ASCE from any and all liability of any nature arising out of or resulting from any use of data provided by the ASCE 7 Hazard Tool.

Elizabeth Sturdy

From: Regan McCarthy <regan.mccarthy@songmasters.org>
Sent: Wednesday, October 5, 2022 5:00 PM
To: Elizabeth Sturdy
Cc: Christopher Senie
Subject: Planning Board Remote Meeting/ Packet / October 12

Per your email to Atty Senie today, I am sending two access ways to a video which we tried to screen share this at the Sept 21 meeting and ran into technical difficulties. We promised to make this accessible to the Planning Board. It will be important for the PB to see this. It is too large a file for the Town's email to accept, and I can bring a copy over for downloading to the Town's iCloud if you want. Alternately, this can be accessed by the PB either by:

1. Send the link [below] to PB members, which will remain available through Oct 21, to this video for viewing and/or downloading.
2. Give the link to the Truro Organizer to show at the October 12th meeting.

[Download Attachment](#)

Available until Oct 21, 2022

Full link is here

https://www.icloud.com/attachment/?u=https%3A%2F%2Fcvws.icloud-content.com%2FB%2FATQ23H2wbsSpUzgDrWDXRvrmMIPAcnm7dzLaQhQBUI0g9VEaYLuvGI%2F%24%7Bf%7D%3Fo%3DAhH62yj2qKplAO_pNGOtqmNoDOwATjIHEycpVI0o6aD-%26v%3D1%26x%3D3%26a%3DCAogECHH-HTIWzhXZAcMND2Qze9vyKITfLP2NJonkKISOb4SdhCP55aFtjAYj_eR2b8wIlgEAKgkC6AMA_yOvpwFSBGUyYU9aBAu68Yh_qJWIsxWHx7ifuTJmof_lydvglYxOX3qGTMbrUZSwGx0HCEDLG3LpyJXmvfol_Iso6cbopNfTEU1iNR0nZEOWxyc8zrTAo1GEwZd0YMyM%26e%3D1666365815%26f%3D%26r%3D7BAE86B1-1F76-4986-83CB-01FA5E0F6A62-1%26k%3D%24%7Buk%7D%26ckc%3Dcom.apple.largeattachment%26ckz%3D2B9365A1-4E65-4B6C-8838-260FA9B1C77A%26p%3D57%26s%3DzLBfd5OIRJOY8jbD0bya3QiyRfl&uk=Hlvd_UQ5MBTKCuy5R00xog&f=IMG_1904.MOV&sz=130836738

Attorney Senie will contact you about handling other items for the Oct 12th meeting.

Thanks and much appreciated - Regan

CAUTION: This email originated from outside of the organization. Do not click links or open attachments unless you recognize the sender and know the content is safe.



1 Cityplace Dr, Suite 490
Creve Coeur, MO 63141

Phone: (314) 513-0147
www.crowncastle.com

July 15th, 2022

Barbara Carboni, Town Planner
Truro Town Hall
24 Town Hall Road
P.O. Box 2030
Truro, MA 02666

RE:

**Notice of Application for Site Plan Review for DISH Wireless Telecommunication Co-
location
Crown Site ID#841273; DISH Site ID# BOSOS00592A
344 Route 6, Truro, MA**

Dear Ms. Carboni

Attached is an application for Site Plan Review, for a new wireless collocation on an existing Crown Castle owned lattice tower located at 344 Route 6, Truro.

DISH officially entered the wireless retail space on July 1, 2020. Today, DISH Wireless is the fourth-largest wireless carrier in the United States with 8.9 million subscribers. DISH provides wireless voice and data services in the United States under the Boost Mobile brand and will provide services under its own brand after its network is built. This Application brought forth pertains to DISH's network build.

This collocation of new Transmission Equipment is for a Wireless Communications Facility ("Facility") located at the Site. The installation consists primarily of the following: adding three (3) antennas, six (6) remote radio units, and one (1) over voltage protection device at the 122' centerline height on the tower, three (3) DC power cables, three (3) fiber trunks and one (1) radio cabinet in the existing fenced compound, as depicted in the attached stamped plans.

Please feel free to contact me with any questions, and I look forward to working with you.

Sincerely,

Katie Adams

Katie Adams
Crown Castle, Agent for DISH Wireless
kadams@nbcllc.com
(781) 392-7547



4545 E River Rd, Suite 320
West Henrietta, NY 14586

Phone: (585) 445-5896
Fax: (724) 416-4461
www.crowncastle.com

Crown Castle Letter of Authorization

**MA - TOWN OF TRURO
Planning Department
24 TOWN HALL ROAD
TRURO, MA 02666**

**Re: Application for Zoning/Building Permit
Crown Castle telecommunications site at:
344 ROUTE 6, NORTH TRURO, MA 02652**

NCWPCS MPL 24 - YEAR SITES TOWER HOLDINGS LLC ("Crown Castle") hereby authorizes DISH Wireless LLC, including their Agent, to act as our Agent in the processing of all zoning applications, building permits and approvals through the TOWN OF TRURO for the existing wireless communications site described below:

**Crown Site ID/Name: 841273/TRURO
Customer Site ID: BOBOS00592A/MA-CCI-T-841273
Site Address: 344 ROUTE 6, NORTH TRURO, MA 02652**

Crown Castle

By:  _____ Date: 7/15/2022
Richard Zajac
Site Acquisition Specialist



100 Apollo Drive Suite 303
Chelmsford, MA 01824

Phone: (360) 561-3311
www.crowncastle.com

October 3rd, 2022

Town Planner
Truro Town Hall
24 Town Hall Road
P.O. Box 2030
Truro, MA 02666

*****NOTICE OF ELIGIBLE FACILITIES REQUEST*****

RE: Request for Minor Modification to Existing Wireless Facility – Section 6409
Site Address: 344 Route 6, Truro, MA
Crown Site ID#841273; DISH Site ID# BOSOS00592A

Planning Board:

On behalf of DISH Wireless L.L.C. (“Dish Wireless” or “Applicant”), Crown Castle USA Inc. (“Crown Castle”) is pleased to submit this request to modify the existing wireless facility noted above through the collocation, replacement and/or removal of the Applicant’s equipment as an eligible facilities request for a minor modification under Section 6409¹ and the rules of the Federal Communications Commission (“FCC”).²

Section 6409 mandates that state and local governments must approve any eligible facilities request for the modification of an existing wireless tower or base station that does not substantially change the physical dimensions of such tower or base station. Under Section 6409, to toll the review period, if the reviewing authority determines that the application is incomplete, it must provide written notice to the applicant within 30 days, which clearly and specifically delineates all missing documents or information reasonably related to whether the request meets the federal requirements.³ Additionally, if a state or local government, fails to issue any approvals required for this request within 60 days, these approvals are deemed granted. The FCC has clarified that the 30-day and 60-day deadlines begins when an applicant: (1) takes the first step required under state or local law; and (2) submits information sufficient to inform the jurisdiction that this modification qualifies under the federal law⁴. Please note that with the submission of this letter and enclosed items, the thirty and sixty-day review periods have started. Based on this filing, the deadline for written notice of incomplete application is November 2nd, 2022, and the deadline for issuance of approval is December 2nd, 2022.

The proposed scope of work for this project includes:

Collocation of antennas, ancillary equipment and ground equipment as per plans for a new carrier on an existing wireless communication facility.

At the end of this letter is a checklist of the applicable substantial change criteria under Section 6409. Additionally, please find enclosed the following information in support of this request:

¹ Middle Class Tax Relief and Job Creation Act of 2012, Pub. L. No. 112-96, § 6409 (2012) (codified at 47 U.S.C. § 1455).

² *Acceleration of Broadband Deployment by Improving Wireless Facility Siting Policies*, 29 FCC Rcd. 12865 (2014) (codified at 47 CFR § 1.6100); and *Implementation of State & Local Governments’ Obligation to Approve Certain Wireless Facility Modification Requests Under Section 6409(a) of the Spectrum Act of 2012*, WT Docket No. 19-250 (June 10, 2020).

³ See 47 CFR § 1.6100 (c)(3). ⁴ See 2020 Upgrade Order at paragraph 16.



100 Apollo Drive Suite 303
Chelmsford, MA 01824

Phone: (360) 561-3311
www.crowncastle.com

- (1) Application for Special Use Permit;
- (2) Construction Drawings;
- (3) Structural Analysis; and
- (4) Section 6409 Substantial Change Checklist.

As these documents indicate, (i) the modification involves the collocation, removal or replacement of transmission equipment; and (ii) such modification will not substantially change the physical dimensions of such tower or base station. As such, it is an “eligible facilities request” as defined in the FCC’s rules to which the 60-day deadline for approval applies. Accordingly, Applicant requests all authorization necessary for this proposed minor modification under Section 6409.

Our goal is to work with you to obtain approvals earlier than the deadline. We will respond promptly to any request for related information you may have in connection with this request. Please let us know how we can work with you to expedite the approval process. We look forward to working with you on this important project, which will improve wireless telecommunication services in your community using collocation on existing infrastructure. If you have any questions, please do not hesitate to contact me.

Regards,

Katie Adams

Katie Adams
Site Acquisition Specialist
Crown Castle
Agent for Applicant
(781) 392-7547
kadams@nbcllc.com



100 Apollo Drive Suite 303
Chelmsford, MA 01824

Phone: (360) 561-3311
www.crowncastle.com

**Section 6409 Substantial Change Checklist
Towers Outside of the Public Right of Way**

The Federal Communications Commission has determined that a modification substantially changes the physical dimension of a wireless tower or base station under 47 U.S.C. § 1455(a) if it meets one of six enumerated criteria under 47 C.F.R. § 1.6100.

Criteria for Towers Outside the Public Rights of Way

YES/NO NO	Does the modification increase the height of the tower by more than the greater of: (a) 10% (b) or, the height of an additional antenna array plus separation of up to 20 feet from the top of the nearest existing antenna?
YES/NO NO	Does the modification add an appurtenance to the body of the tower that would protrude from the edge of the tower more than 20 feet or more than the width of the tower structure at the level of the appurtenance, whichever is greater?
YES/NO NO	Does the modification involve the installation of more than the standard number of new equipment cabinets for the technology involved or add more than four new equipment cabinets?
YES/NO NO	Does the modification entail any excavation or deployment outside the current site by more than 30 feet in any direction, not including any access or utility easements?
YES/NO NO	Does the modification defeat the concealment elements of the eligible support structure?
YES/NO NO	Does the modification violate conditions associated with the siting approval with the prior approval the tower or base station other than as specified in 47 C.F.R. § 1.6100(c)(7)(i) – (iv)?

If all questions in the above section are answered “NO,” then the modification does not constitute a substantial change to the existing tower under 47 C.F.R. § 1.6100.



Town of Truro Planning Board

P.O. Box 2030, Truro, MA 02666

APPLICATION FOR TELECOMMUNICATION STRUCTURES, BUILDINGS AND APPURTENANCES SITE PLAN REVIEW

To the Town Clerk and the Planning Board of the Town of Truro, MA

Date 7/15/2022

The undersigned hereby files an application with the Truro Planning Board for the following:

Site Plan Review pursuant to §40.5 of the Truro Zoning Bylaw

1. General Information

Description of Property and Proposed Project DISH Wireless collocation on an existing Lattice Tower located at 344 Route 6. DISH to install 3 panel antennas and ancillary equipment on the existing tower, with a 5'x7' pad for equipment cabinet on the ground, within the existing compound, as per plans.

Property Address 344 Route 6, Truro Map(s) and Parcel(s) 39-172-A

Registry of Deeds title reference: Book _____, Page _____, or Certificate of Title Number _____ and Land Ct. Lot # _____ and Plan # _____

Applicant's Name Katie Adams on behalf of Crown Castle (Written Permission attached)

Applicant's Legal Mailing Address 100 Apollo Drive, Suite 303, Chelmsford MA 01824

Applicant's Phone(s), Fax and Email 781-392-7547 kadams@nbcllc.com

Applicant is one of the following: (please check appropriate box)

*Written Permission of the owner is required for submittal of this application.

Owner Prospective Buyer* Other*

Owner's Name and Address Crown Castle 4545 E. River Rd. Suite 320, West Henrietta, NY 14586

Representative's Name and Address Richard Zajac 4545 E. River Rd. Suite 320, West Henrietta, NY 14586

Representative's Phone(s), Fax and Email 585-445-5896 Richard.Zajac@crowncastle.com

2. Waiver(s) Request – The Planning Board may, upon the request of the applicant, pursuant to §70.3.E, waive requirements of §40.5, provided that in the opinion of the Planning Board such a waiver would not be detrimental to the public interest, cause the Town any expense, or be inconsistent with the intent and purpose of this Bylaw. A request for a waiver by the applicant shall be accompanied by a reasonable explanation as to why the waiver is being requested. If multiple waivers are requested, the applicant shall explain why each waiver is requested.

- The applicant is **advised** to consult with the Building Commissioner, Planning Department, Conservation Department, and/or Health Department prior to submitting this application.

Signature(s)

Katie Adams

Applicant(s)/Representative Printed Name(s)

Katie Adams

Applicant(s)/Representative Signature(s)

Owner(s) Printed Name(s) or written permission

Owner(s) Signature(s) or written permission

Your signature on this application authorizes the Members of the Planning Board and town staff to visit and enter upon the subject property.

40.5 - COMMUNICATION STRUCTURES, BUILDINGS AND APPURTENANCES - Applicant

Address: <u>344 Route 6</u> Applicant Name: <u>Katie Adams c/o Crown Castle</u> Date: <u>7/15/2022</u>				
No.	Requirement	Included	Not Included	Explanation, if needed
<u>B. Requirements</u>				
1	All building permits for a communications structure, building or appurtenance shall require a special permit from the Planning Board.			seeking SP
2	The minimum distance from the perimeter of the communications structure to any property line shall be the height of the structure including any antennas or appurtenances, plus ten (10) feet. The minimum distance from any guy wire, anchor or brace to any property line shall be the length of the guy wire or brace plus ten (10) feet. The setbacks for a communications building shall comply with the setback requirements of the zoning district.	X		
3	The communications structure, building or appurtenance shall be installed, maintained and operated in accordance with all applicable federal, state, county and local codes, standards and regulations and shall be designed to withstand sustained winds and gusts of a category 5 hurricane. If Federal Aviation Administration (FAA) or Federal Communications Commission (FCC) regulations are changed, then the owner or operator shall bring the structure, building and appurtenances into compliance with the new regulations within six (6) months of the effective date of such regulations or earlier if a more stringent compliance schedule is included in the regulation. Failure to comply with any new regulations shall be grounds for the removal of non-complying structures, buildings and appurtenances at the owner's expense.	X		
4	The height of the communications structure (tower) shall be no greater than one hundred and fifty (150 feet) above ground level.			n/a - tower existing
5	Communication antennas shall be located on pre-existing structures unless the applicant demonstrates that there are no feasible pre-existing structures. The installation shall preserve the character of such pre-existing structures.	X		
6	If the applicant has demonstrated that there are no feasible pre-existing structures to support antennas and appurtenances for the intended use, then any communications structure, building or appurtenance may be sited on public land.			n/a

40.5 - COMMUNICATION STRUCTURES, BUILDINGS AND APPURTENANCES - Applicant

Address: <u>344 Route 6</u> Applicant Name: <u>Katie Adams c/o Crown Castle</u> Date: <u>7/15/2022</u>				
No.	Requirement	Included	Not Included	Explanation, if needed
7	To the extent lawful and feasible, all service providers shall co-locate on a single tower. Towers shall be designed to structurally accommodate the maximum number of foreseeable users (within a ten-year period) technically practicable. The applicant is required to document all co-location tenants and provide a tower design indicating types and location of all facilities.	x		
8	New facilities or structures shall be considered only upon a finding by the Planning Board that existing or approved facilities or structures cannot accommodate the wireless communications equipment planned for the proposed tower.			n/a
9	The installation of a communications structure, building or appurtenance shall be designed to minimize visual impact; the maximum amount of natural vegetation shall be preserved; details of construction and finish shall blend with the surroundings; additional vegetative screening shall be employed where practical and particularly to screen abutting residential property whether developed or not. A detailed landscape plan will be required with the application.	x		
10	Location and siting of facilities and structures shall be consistent with any regional location and siting criteria established by the Cape Cod Commission.			n/a
11	Under normal operating conditions, noise emanating from the communications structure, building or appurtenance shall not be greater at the boundary of the lot on which it is sited than would otherwise exist in the absence of these facilities.	x		
12	No hazardous waste shall be discharged on the site. Any storage of fuel shall be in compliance with the Board of Health regulations. Documentation shall be provided for the contents of all communications buildings and/or cabinets.			n/a
13	All run-off of storm water from communications structures, buildings, and appurtenances, driveways and parking areas shall be contained on site; the amount of impervious surface on the site shall be minimized.	x		
14	Lighting, when required and permitted by the FAA or the Planning Board, shall be directed inward so as not to project onto surrounding properties.			n/a

40.5 - COMMUNICATION STRUCTURES, BUILDINGS AND APPURTENANCES - Applicant

Address: <u>344 Route 6</u> Applicant Name: <u>Katie Adams c/o Crown Castle</u> Date: <u>7/15/2022</u>				
No.	Requirement	Included	Not Included	Explanation, if needed
15	All structures, buildings or appurtenances must be secured to control access. Fencing materials shall be consistent with the character of abutting properties, with a locked gate and proper warning signals. A sign must be displayed indicating the name of the owner(s) and a 24 hour contact number. Only signs limited to safety will be allowed. Fencing is not required for antennas or other appurtenances mounted on a pre-existing structure.			n/a
16	As a condition of approval of the application the applicant shall agree, by execution of a covenant, to remove within six months any communications structure and building which has not operated for four consecutive months unless the cause is major damage which prohibits operation. In the event that major damage has rendered the facility inoperative, repair or removal of the facility shall begin within six months and be completed within an additional six months. Failure to comply with the conditions of the covenant shall be grounds for the removal of structures, buildings and appurtenances. Complete restoration of the site shall be at the owner(s) expense, secured by a bond from a recognized financial institution. The covenant shall include, also at the owner(s) expense, provision for liability insurance for any damage to any abutting property whether developed or not.	X		
17	At least forty-five (45) days before submitting an application for a special permit for the installation of a communications structure, building or appurtenance the applicant shall consult with the Planning Board. The purpose of the consultation is to facilitate the permitting process by the exchange of information between the applicant and the Planning Board, and for the applicant to obtain a detailed description of the information and documentation required, in writing, by the Planning Board, in order to clarify and resolve concerns of the Board and minimize potential problems with the application.	X		
18	The Planning Board shall hold a public hearing within sixty-five (65) days of the filing of an application and shall issue a decision within ninety (90) days following the date of the public hearing.			
19	The applicant shall submit the following written information to the Planning Board:			

40.5 - COMMUNICATION STRUCTURES, BUILDINGS AND APPURTENANCES - Applicant

Address: 344 Route 6 **Applicant Name:** Katie Adams c/o Crown Castle **Date:** 7/15/2022

No.	Requirement	Included	Not Included	Explanation, if needed
19.a.	A survey of all sites for the installation of communications structures, buildings or appurtenances which are feasible for providing the intended services. The survey shall include a rationale for the selection of a prime and at least one alternative site. All sites in Truro shall be located on the appropriate sheet(s) of the Truro Assessor's Atlas;			n/a
19.b.	A survey of all pre-existing structures which are capable of supporting the equipment necessary to provide the intended service and a technical report which demonstrates why any such structure cannot be used by the applicant;			n/a
19.c.	The radiation pattern of all proposed antennas showing the frequency and intensity of radiation at ground level and at 30 feet above ground level. At the expense of the applicant, Electro Magnetic Field (EMF) readings shall be provided to the Board of Health yearly and immediately after any addition to the facility;	x		
19.d.	The sound level in decibels at ground level, at 30 feet above ground level and at the top of the facility and 10, 50, 100 and 500 feet from the communications structure, building or appurtenances for wind velocities between calm and 100 miles per hour with all equipment operating at normal levels, including before condition measured, after condition prediction and cumulative condition (with co-location) prediction;			n/a
19.e.	A delineation of the Assessor's Atlas of all areas in Truro which will not be served by the proposed installation for the prime and an alternative site;			n/a
19.f.	A statement of the services to be supported by the proposed communications structure, building or appurtenance;	x		
19.g.	Plans of special design features and materials, including landscaping, to minimize the visual impact of proposed communications structures, buildings and appurtenances. Site plans, elevations and fall zone should be included;			n/a
19.h.	A certification that the applicant has complied with all federal (including FAA), state and regional requirements to provide the proposed service and demonstration of compliance with the FCC guidelines for EMF's under National Environmental Policy Act (NEPA), including copies of the FCC Form 600, plus Environmental Assessment/Environmental Impact Statements as applicable;	x		

40.5 - COMMUNICATION STRUCTURES, BUILDINGS AND APPURTENANCES - Applicant

Address: <u>344 Route 6</u> Applicant Name: <u>Katie Adams c/o Crown Castle</u> Date: <u>7/15/2022</u>				
No.	Requirement	Included	Not Included	Explanation, if needed
19.i.	Within thirty (30) days after the application filing, the applicant shall arrange to fly a three-foot-diameter balloon at the primary and an alternate site at the maximum height of the proposed installation. The date and location of the flights shall be advertised at least 14 days, but not more than 21 days before the flights, in a newspaper with a general circulation in Truro. Photos shall be provided from all strategic viewing points, per agreement with the Planning Board prior to flight.			n/a
20	If a communications structure, building or appurtenance is to be installed on a pre-existing private structure or on land or a structure owned, prior to the effective date of the bylaw, by the Commonwealth of Massachusetts, or on land or a structure owned by the Town of Truro, the applicant shall submit the following written information to the Planning Board:			
20.a.	A draft contract, including requirements for removal of all structures and for complete site restoration in the case of discontinued use, between the applicant and the owner (if different from the applicant).			
20.b.	A description of the proposed facility at the proposed prime and alternate sites including:			n/a
	i) Height of the facility and its associated equipment and antennas;			
	ii) Access roads and power supplies;			
	iii) Type, size and number of transmitters;			
	iv) A list of all fuels to be used on the site and a detailed description of how each shall be contained.			
20.c.	A site plan (scale not less than 1 inch=40 feet), showing the proposed facility, fall zones, existing and proposed contour elevations, 100-year flood zones, water resources, Zones of Contribution, waterways, wetlands and all associated equipment and structures on the site, including elevations of all equipment and structures with sufficient detail to delineate the external finish of all structures and equipment; and			
20.d.	A landscape plan showing the proposed site before and after development, including topography and screening proposed to protect abutters.			
21	For all applications other than those set forth in § 40.5.B.20 above, the applicant shall submit the following written information to the Planning Board:			

40.5 - COMMUNICATION STRUCTURES, BUILDINGS AND APPURTENANCES - Applicant

Address: <u>344 Route 6</u> Applicant Name: <u>Katie Adams c/o Crown Castle</u> Date: <u>7/15/2022</u>				
No.	Requirement	Included	Not Included	Explanation, if needed
21.a.	A statement of the purpose for which the application is made.	X		
21.b.	The exact legal name of each person seeking a special permit and the address and telephone number or principal place of business of each such person.	X		
21.c.	The name, title, address and telephone number of the attorney or other person to whom correspondence or communications in regard to the application are to be addressed. Notice, orders, and other papers may be served upon the person so named, and such service shall be deemed to be service upon the applicant;	X		
21.d.	A statement of the need for the proposed facility with as much specific information as is practicable to demonstrate the need, including description of the proposed system and how the proposed facility would eliminate or alleviate any existing deficiency or limitation, including all co-location facilities;			n/a
21.e.	A statement of the benefits expected from the proposed facility with as much information as is practicable;			n/a
21.f.	A description of the proposed facility at the proposed prime and alternate sites including:			n/a
	i) Height of the facility and its associated equipment and antennas;			
	ii) Access roads and power supplies;			
	iii) Special design features and materials, including landscape plans;			
	iv) Type, size and number of transmitters and receivers, as well as the signal frequency, power output, and power density at the tower base, site boundary, and building where people might be exposed to the maximum power densities from the facility;			
	v) A map showing any fixed facilities with which the proposed facility would interact;			
	vi) The coverage signal strength, and integration of the proposed facility with any adjacent fixed facility, to be accompanied by a network plan showing interfaces with any adjacent service areas;			
	vii) A forecast of when maximum capability would be reached for the proposed facility and for facilities that would be integrated with the proposed facility;			
	viii) Documentation of contents of communications buildings and/or cabinets.			

40.5 - COMMUNICATION STRUCTURES, BUILDINGS AND APPURTENANCES - Applicant

Address: <u>344 Route 6</u> Applicant Name: <u>Katie Adams c/o Crown Castle</u> Date: <u>7/15/2022</u>				
No.	Requirement	Included	Not Included	Explanation, if needed
21.g.	A description of the proposed prime and alternative site, including:			N/a
	i) The most recent U.S.G.S. topographic quadrangle map (scale 1 inch = 2,000 feet) marked to show the site of the facility and any significant changes within a one-mile-radius of the site;			
	ii) A map (scale not less than 1 inch = 200 feet) of the lot or tract on which the facility is proposed to be located, showing the acreage and dimensions of such site, the name and location of adjacent public and private roads or the nearest public road, and the names of abutting owners and portions of their lands abutting the site;			
	iii) A site plan (scale not less than 1 inch = 40 feet), showing the proposed facility, fall zones, existing and proposed contour elevations, 100-year flood zones, water resources, Zones of Contribution, waterways, wetlands and all associated equipment and structures on the site, including elevations of all equipment and structures with sufficient detail to delineate the external finish of all structures and equipment;			
	iv) Where relevant, a terrain profile showing the proposed facility and access road and existing and proposed grades; and			
	v) The most recent aerial photograph (scale not less than 1 inch = 1,000 feet) showing the proposed site, access roads and all abutting properties.			
21.h.	A statement explaining mitigation measures for the proposed facility including:			N/a
	i) Construction techniques designed specifically to minimize adverse effects on natural areas and sensitive areas;			
	ii) Special design features made specifically to avoid or minimize adverse effects on natural areas and sensitive areas;			
	iii) Establishment of vegetation proposed near residential, recreation, and scenic areas;			
	iv) Special design features made specifically so that the proposed structures, buildings and appurtenances shall blend with pre-existing structures and buildings;			
	v) Methods for preservation of vegetation for wildlife habitat and screening;			

40.5 - COMMUNICATION STRUCTURES, BUILDINGS AND APPURTENANCES - Applicant

Address: <u>344 Route 6</u> Applicant Name: <u>Katie Adams c/o Crown Castle</u> Date: <u>7/15/2022</u>				
No.	Requirement	Included	Not Included	Explanation, if needed
	vi) A list of all fuels to be used on the site and a detailed description of how each shall be contained; and			
	vii) A statement describing any hazardous materials or wastes (including quantities) to be used or generated on the site.			
21.i.	A description of the existing and planned land uses of the proposed prime and alternative sites and surrounding areas;			
21.j.	A description of the scenic, natural, historic, and recreational characteristics of the proposed prime and alternative sites and surrounding areas;			
21.k.	Sight-line graphs to the proposed prime and alternative sites from visually impacted areas (a site from which the facility can be seen) such as residential developments, recreational areas, and historic sites;			
21.l.	A list describing the type and height of all existing and proposed communication structures, buildings and appurtenances within a ten-mile radius within the search area, or within any other area from which use of the proposed prime or alternative structure might be feasible from a location standpoint for purposes of the application;			
21.m.	A description of efforts to share existing and proposed structures, or consolidate telecommunications antennas of public and private services onto the proposed facility;			
21.n.	A description of the technical alternatives and a statement containing justification for the proposed facility;			
21.o.	A description of rejected sites with a U.S.G.S. topographic quadrangle map (scale 1 inch = 2,000 feet) marked to show the location of rejected sites;			
21.p.	A detailed description and justification for the site selected, including a description of siting criteria and the process by which other possible sites were considered and eliminated including but not limited to, environmental effects, cost differential, coverages lost or gained, potential interference with other facilities, and signal loss due to topographical features compared to the proposed prime and alternate sites;			
21.q.	A statement describing hazards to human health, if any, with supporting data and references to regulatory standards;			
21.r.	A statement of the estimated costs for site acquisition and construction of a facility at the prime and alternative sites;			

40.5 - COMMUNICATION STRUCTURES, BUILDINGS AND APPURTENANCES - Applicant

Address: <u>344 Route 6</u> Applicant Name: <u>Katie Adams c/o Crown Castle</u> Date: <u>7/15/2022</u>				
No.	Requirement	Included	Not Included	Explanation, if needed
21.s.	A schedule showing the proposed program of site acquisition, construction, completion, operation and relocation or removal of the existing facilities for the prime and alternative sits;			
21.t.	A copy of any filing or application that the applicant has been required to make together with any decision with regard to such filing or application;			
21.u.	A landscape plan showing the proposed site and location before and after development, including topography screening proposed to protect abutters;			
21.v.	Plans which show location and siting at a prime and at an alternate site; and			
21.w.	A technical report which demonstrates that the maximum height of the installation is the minimum feasible to provide the intended service.			
22	All written information submitted in accordance with the requirements listed in any previous section of this bylaw shall be certified by an appropriate licensed professional.			
23	The Planning Board may also refer applications to the Board of Health, the Zoning Board of Appeals, and the Conservation Commission for review.			
24	The Planning Board shall not approve any application that does not comply with all the requirements of this bylaw. The Board does, however, have the right to waive any part of this bylaw, when in its opinion, such a waiver would not be detrimental to the public interest, cause the Town any expense, or be inconsistent with the intent and purpose of this bylaw.			
25	Any permit issued by the Planning Board for a communications facility shall be valid for the applicant only; it may not be reassigned, leased or sold.			
26	Municipal and private, non-commercial uses are exempted from this bylaw.			
27	The Planning Board shall act in accordance with the standards and requirements set forth herein and in accordance with the Massachusetts General Laws.			
28	The invalidity of any section of this bylaw shall not invalidate any other section.			



TOWN OF TRURO

Assessors Office

Certified Abutters List

Request Form

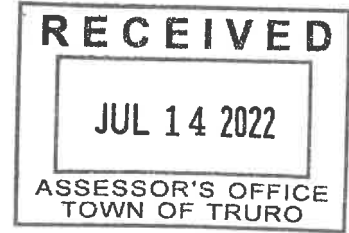

DATE: 7/14/2022

NAME OF APPLICANT: DISH Wireless

NAME OF AGENT (if any): Katie Adams, on behalf of Crown Castle

MAILING ADDRESS: 100 Apollo Drive Suite 303 Chelmsford MA 01824

CONTACT: HOME/CELL 781-392-7547 EMAIL kadams@nbcllc.com

PROPERTY LOCATION: 344 Route 6
(street address)

PROPERTY IDENTIFICATION NUMBER: MAP 39 PARCEL 172 EXT. A
(if condominium)

ABUTTERS LIST NEEDED FOR: (please check all applicable) **FEE: \$15.00 per checked item**
(Fee must accompany the application unless other arrangements are made)

- | | | |
|---|---|--|
| <input type="checkbox"/> Board of Health ⁵ | <input type="checkbox"/> Planning Board (PB) | <input type="checkbox"/> Zoning Board of Appeals (ZBA) |
| <input type="checkbox"/> Cape Cod Commission | <input checked="" type="checkbox"/> Special Permit ¹ | <input type="checkbox"/> Special Permit ¹ |
| <input type="checkbox"/> Conservation Commission ⁴ | <input type="checkbox"/> Site Plan ² | <input type="checkbox"/> Variance ¹ |
| <input type="checkbox"/> Licensing | <input type="checkbox"/> Preliminary Subdivision ³ | |
| Type: _____ | <input type="checkbox"/> Definitive Subdivision ³ | |
| | <input type="checkbox"/> Accessory Dwelling Unit (ADU) ² | |
| <input type="checkbox"/> Other _____ | (Fee: Inquire with Assessors) | |
- (Please Specify)

Note: Per M.G.L., processing may take up to 10 calendar days. Please plan accordingly.

THIS SECTION FOR ASSESSORS OFFICE USE ONLY

Date request received by Assessors: 7/14/2022 Date completed: 7/14/2022
 List completed by: [Signature] Date paid: 7/14/2022 Cash/Check online CC

¹Abutters, owners of land directly opposite on any public or private street or way, and abutters to the abutters within 300 feet of the property line.
²Abutters to the subject property, abutters to the abutters, and owners of properties across the street from the subject property.
³Landowners immediately bordering the proposed subdivision, landowners immediately bordering the immediate abutters, and landowners located across the streets and ways bordering the proposed subdivision. **Note:** For Definitive Subdivision only, responsibility of applicant to notify abutters and produce evidence as required.
⁴All abutters within 300 feet of parcel, except Beach Point between Knowles Heights Road and Provincetown border, in which case it is all abutters within 100 feet. **Note:** Responsibility of applicant to notify abutters and produce evidence as required.
⁵Abutters sharing any boundary or corner in any direction – including land across a street, river or stream. **Note:** Responsibility of applicant to notify abutters and produce evidence as required.



TRURO ASSESSORS OFFICE
PO Box 2012 Truro, MA 02666
Telephone: (508) 214-0921
Fax: (508) 349-5506

Date: July 14, 2022

To: Katie Adams on behalf of Crown Castle, Agent for DISH Wireless

From: Assessors Department

Certified Abutters List: 344 Route 6 (Map 39, Parcel 172)

Planning Board/Special Permit

Attached is a combined list of abutters for the property located at 344Route 6.

The current owner is Town of Truro.

The names and addresses of the abutters are as of July 8, 2022 according to the most recent documents received from the Barnstable County Registry of Deeds.

Certified by: _____

Olga Farrell
Assessing Clerk

Abutters List Within 300 feet of Parcel 39/172/A

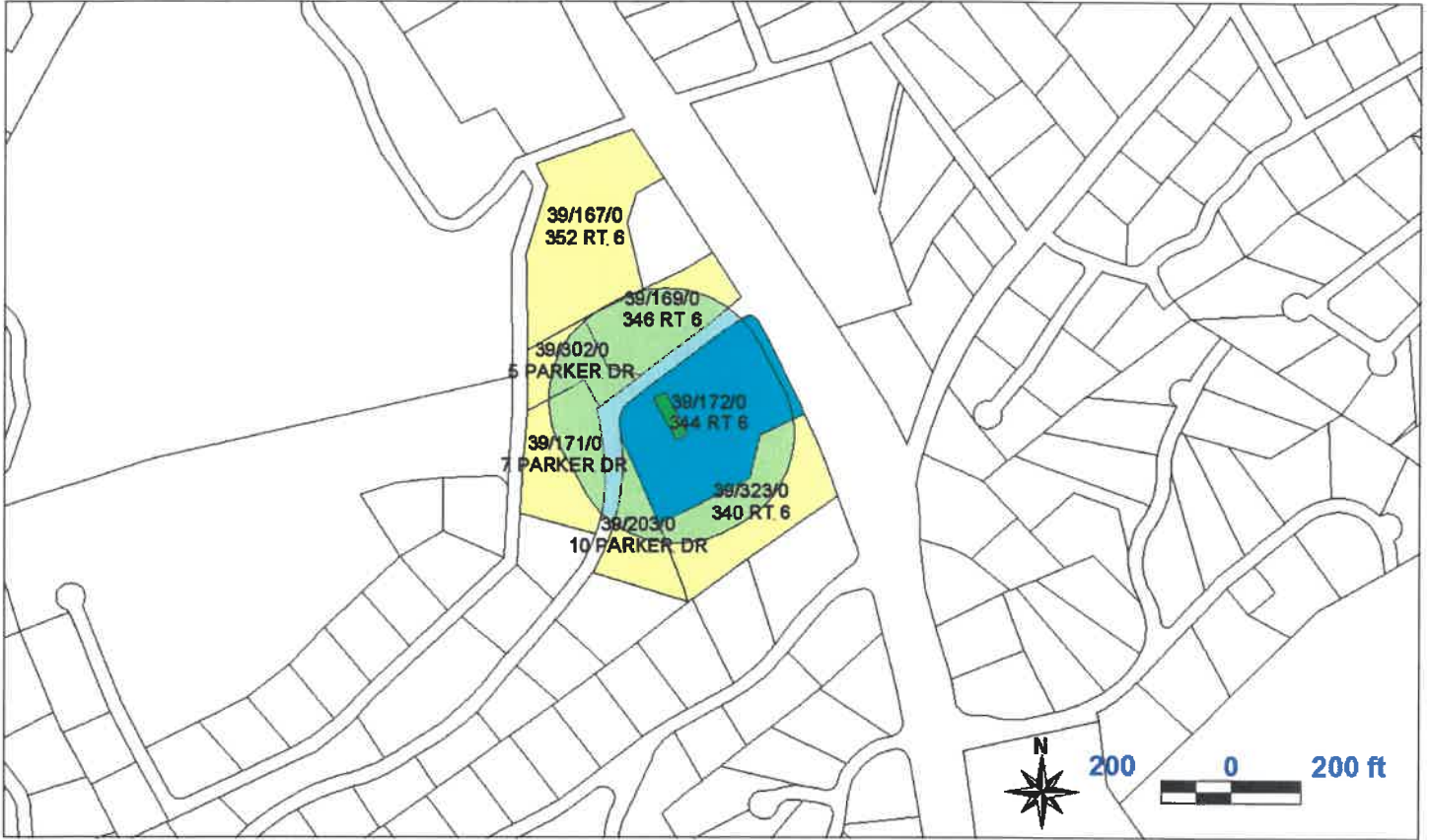

Key	Parcel ID	Owner	Location	Mailing Street	Mailing City	ST	ZipCd/Country
1291	39-167-0-R	TRI-S PROPERTIES LLC	352 RT 6	PO BOX 1081	TRURO	MA	02666-1081
1293	39-169-0-R	SEAMENS BANK	346 RT 6	PO BOX 74	NO TRURO	MA	02652
1294	39-171-0-R	WESTVIEW COURT REALTY TRUST C/O TRIBUNA JR MICHAEL A	7 PARKER DR	192 MILTON ST	QUINCY	MA	02170
1295	39-172-0-E	TOWN OF TRURO	344 RT 6	PO BOX 2030	TRURO	MA	02666-2030
1296	39-172-A-R	SOUTHWESTERN BELL MOBILE SYSTE D/B/A CINGULAR WRLS-AT&T SVCS	344 RT 6	ATTN: TOWER PROPERTY TAX TEAM 754 PEACHTREE ST, 16TH FLR	ATLANTA	GA	30308
1324	39-203-0-R	COHEN JENNIFER S	10 PARKER DR	110 W 96TH ST #11A	NEW YORK	NY	10025
1421	39-302-0-R	PRIDEAUX-BRUNE DIANA & MAHONEY ANNE	5 PARKER DR	10 MUSEUM WAY, UNIT 1929	CAMBRIDGE	MA	02141
6429	39-323-0-E	TOWN OF TRURO	340 RT 6	PO BOX 2030	TRURO	MA	02666-2030

WJH/KP/2022

39-167-0-R

TRI-S PROPERTIES LLC
PO BOX 1081
TRURO, MA 02666-1081

39-169-0-R

SEAMENS BANK
PO BOX 74
NO TRURO, MA 02652

39-171-0-R

WESTVIEW COURT REALTY TRUST
C/O TRIBUNA JR MICHAEL A
192 MILTON ST
QUINCY, MA 02170

39-172-0-E

TOWN OF TRURO
PO BOX 2030
TRURO, MA 02666-2030

39-172-A-R

SOUTHWESTERN BELL MOBILE SYSTE
D/B/A CINGULAR WRLS-AT&T SVCS
ATTN: TOWER PROPERTY TAX TEAM
754 PEACHTREE ST, 16TH FLR
ATLANTA, GA 30308

39-203-0-R

COHEN JENNIFER S
110 W 96TH ST #11A
NEW YORK, NY 10025

39-302-0-R

PRIDEAUX-BRUNE DIANA &
MAHONEY ANNE
10 MUSEUM WAY, UNIT 1929
CAMBRIDGE, MA 02141

39-323-0-E

TOWN OF TRURO
PO BOX 2030
TRURO, MA 02666-2030



Date: 7/17/2021

Crown Castle
 2000 Corporate Drive
 Canonsburg, PA 15317
 (724) 416-2000

Subject: Structural Evaluation

Carrier Designation: DISH Network Co-Locate
Site Number: BOBOS00592A
Site Name: MA-CCI-T-841273

Crown Castle Designation: **BU Number:** 841273
Site Name: TRURO
JDE Job Number: 644620
WO Number: 1968406
Order Number: 552716 Rev. 0

Site Data: 344 Route 6, North Truro, Barnstable County, MA
 Latitude: 42° 1' 18" Longitude: -70° 4' 30"
 170 Foot – Self Support Tower

Crown Castle is pleased to submit this “Structural Evaluation” to determine the structural integrity of the above-mentioned tower. The purpose of this evaluation is to determine the suitability of the tower structure to support the proposed equipment configuration listed in Table 1.

Based on a comparison of loading listed in the previous analysis dated 3/27/2019, the proposed loading change will not have a significant impact on the overall tower stress rating. Therefore, the final proposed equipment configuration listed in Table 1 is structurally **ACCEPTABLE**.

Table 1: Proposed Equipment Configuration

Mounting Level (ft)	Center Line Elevation (ft)	Number of Antennas	Antenna Manufacturer	Antenna Model	Number of Feed Lines	Feed Line Size (in)
122	122	1	RAYCAP	RDIDC-9181-PF-48	1	1-1/2
		3	FUJITSU	TA08025-B604		
		3	FUJITSU	TA08025-B605		
		3	JMA WIRELESS	MX08FRO665-21		
		3	MOUNTS	Commscope MTC3975083		

Respectfully submitted by:

Bradley E. Byrom, P.E., S.E.
 Senior Project Engineer



Digitally signed by Bradley E Byrom
 Date: 2021.07.17 10:29:52 -04'00'



Nationwide Programmatic Agreement Co-location Criteria Verification Form

Site Name: TRURO
Business Unit Number: 841273 App ID: 552716
Site Address: 344 ROUTE 6 NORTH TRURO, MA 02652
Carrier Name: DISH Wireless L.L.C.
Customer Site ID: BOBOS00592A

Tower was built on or before 3/16/01? YES NO

Criteria for Programmatic Agreement Eligibility for Towers Built on or before March 16, 2001

- YES NO The mounting of the antenna will result in a substantial increase in the size of the tower¹.
- YES NO The tower has been found by the FCC to have an adverse or potentially adverse effect that has not been resolved through an MOA or other mechanism.
- YES NO The tower is the subject of a pending environmental review or proceeding before the FCC involving compliance with Section 106 of the NHPA.
- YES NO The tower owner has received written or electronic notice from the FCC that the FCC is in receipt of a complaint from a member of the public, a SHPO or the Council that the co-location has an adverse effect on one or more historic properties.

Criteria for Programmatic Agreement Eligibility for Towers Built after March 16, 2001

- YES NO No Section 106 review (SHPO review) or any associated environmental (NEPA) review required by the FCC has been completed for this tower.
- YES NO The mounting of the antenna will result in a substantial increase in the size of the tower.¹
- YES NO The tower is the subject of a pending environmental review or proceeding before the FCC involving compliance with Section 106 of the NHPA.
- YES NO The tower owner has received written or electronic notice from the FCC that the FCC is in receipt of a complaint from a member of the public, a SHPO or the Council that the co-location has an adverse effect on one or more historic properties.

If any of the above answers are "YES," consultation with the SHPO is required prior to placement of the antenna on the tower.

Approved By: *Christopher Page* 11/11/2021

A COPY OF THIS COMPLETED FORM MUST BE PROVIDED TO THE CARRIER AND TO THE CROWN CASTLE REGULATORY DEPARTMENT.

¹ Substantial increase in size of the tower" means: 1) an increase in the tower height of more than 10% or by the height of one antenna array with a separation distance from the nearest existing array not to exceed 20 feet, whichever is greater; 2) the installation of more than 4 new equipment cabinets or more than 1 new equipment building; 3) the addition of an appurtenance that would protrude from the edge of the tower more than 20 feet or more than the width of the tower at the level of the appurtenance, whichever is greater; or 4) the mounting of the antenna would involve excavation more than 30' in any direction outside the current boundaries of the site and any access or utility easements currently related to the site.



DISH Wireless L.L.C. SITE ID:
BOBOS00592A

DISH Wireless L.L.C. SITE ADDRESS:
**344 ROUTE 6
NORTH TRURO, MA 02652**

SCOPE OF WORK

THIS IS NOT AN ALL INCLUSIVE LIST. CONTRACTOR SHALL UTILIZE SPECIFIED EQUIPMENT PART OR ENGINEER APPROVED EQUIVALENT. CONTRACTOR SHALL VERIFY ALL NEEDED EQUIPMENT TO PROVIDE A FUNCTIONAL SITE. THE PROJECT GENERALLY CONSISTS OF THE FOLLOWING:

- TOWER SCOPE OF WORK:**
- INSTALL (3) PROPOSED PANEL ANTENNAS (1 PER SECTOR)
 - INSTALL (3) PROPOSED SECTOR FRAMES
 - INSTALL PROPOSED JUMPERS
 - INSTALL (6) PROPOSED RRUs (2 PER SECTOR)
 - INSTALL (1) PROPOSED OVER VOLTAGE PROTECTION DEVICE (OVP)
 - INSTALL (1) PROPOSED HYBRID CABLE

- GROUND SCOPE OF WORK:**
- INSTALL (1) PROPOSED METAL PLATFORM
 - INSTALL (1) PROPOSED ICE BRIDGE
 - INSTALL (1) PROPOSED PPC CABINET
 - INSTALL (1) PROPOSED EQUIPMENT CABINET
 - INSTALL (1) PROPOSED POWER CONDUIT
 - INSTALL (1) PROPOSED TELCO CONDUIT
 - INSTALL (1) PROPOSED TELCO-FIBER BOX
 - INSTALL (1) PROPOSED GPS UNIT
 - INSTALL (1) PROPOSED SAFETY SWITCH (IF REQUIRED)
 - INSTALL (1) PROPOSED FIBER NID (IF REQUIRED)
 - INSTALL (1) PROPOSED NEW 200A METER IN EXISTING SOCKET

SITE INFORMATION

PROPERTY OWNER: TOWN OF TRURO, MA
 PROPERTY OWNER ADDRESS: 24 TOWN HALL ROAD TRURO, MA 02666
 TOWER TYPE: SELF SUPPORT
 TOWER CO SITE ID: 841273
 TOWER APP NUMBER: 552716
 COUNTY: BARNSTABLE
 LATITUDE (NAD 83): 42° 1' 18.00" N 42.02166667
 LONGITUDE (NAD 83): 70° 4' 30.00 W -70.07500000
 ZONING JURISDICTION: TOWN OF TRURO, MA
 ZONING DISTRICT: R (RESIDENTIAL)
 PARCEL NUMBER: 039-000-172-00
 OCCUPANCY GROUP: U
 CONSTRUCTION TYPE: II-B
 POWER COMPANY: EVERSOURCE
 TELEPHONE COMPANY: CROWN CASTLE

PROJECT DIRECTORY

APPLICANT: DISH Wireless L.L.C.
 5701 SOUTH SANTA FE DRIVE
 LITTLETON, CO 80120
 TOWER OWNER: CROWN CASTLE
 2000 CORPORATE DRIVE
 CANONSBURG, PA 15317
 (877) 486-9377
 SITE DESIGNER: HUDSON DESIGN GROUP, LLC.
 45 BEECHWOOD DRIVE
 NORTH ANDOVER, MA 01845
 (978) 557-5553
 SITE ACQUISITION: COURTNEY PRESTON
 courtney.preston.contractor
 @crownncastle.com
 CONSTRUCTION MANAGER: TIMOTHY HARDY
 timothy.hardy@dish.com
 RF ENGINEER: NAGESH NAYAK
 nagesh.nayak@dish.com



5701 SOUTH SANTA FE DRIVE
LITTLETON, CO 80120



45 BEECHWOOD DRIVE N. ANDOVER, MA 01845 TEL: (978) 557-5553 FAX: (978) 336-5586



IT IS A VIOLATION OF LAW FOR ANY PERSON, UNLESS THEY ARE ACTING UNDER THE DIRECTION OF A LICENSED PROFESSIONAL ENGINEER, TO ALTER THIS DOCUMENT.

DRAWN BY: PS CHECKED BY: SMA APPROVED BY: DPH

RFDS REV #: 0

PRELIMINARY DOCUMENTS

SUBMITTALS		
REV	DATE	DESCRIPTION
A	11/15/2021	ISSUED FOR REVIEW
B	01/21/2022	ISSUED FOR REVIEW

A&E PROJECT NUMBER
BOBOS00592A

DISH Wireless L.L.C.
PROJECT INFORMATION
BOBOS00592A
CROWN CASTLE BU#841273
344 ROUTE 6
NORTH TRURO, MA 02652

SHEET TITLE
TITLE SHEET

SHEET NUMBER
T-1

MASSACHUSETTS CODE OF COMPLIANCE

ALL WORK SHALL BE PERFORMED AND MATERIALS INSTALLED IN ACCORDANCE WITH THE CURRENT EDITIONS OF THE FOLLOWING CODES AS ADOPTED BY THE LOCAL GOVERNING AUTHORITIES. NOTHING IN THESE PLANS IS TO BE CONSTRUED TO PERMIT WORK NOT CONFORMING TO THESE CODES

CODE TYPE	CODE
BUILDING	MA STATE BUILDING CODE, 9TH EDITION (780 CMR)/2015 IBC W/ AMENDMENTS
MECHANICAL	MA STATE BUILDING CODE, 9TH EDITION (780 CMR)/2015 IMC W/ AMENDMENTS
ELECTRICAL	MA ELECTRICAL CODE/2020 NEC W/ AMENDMENTS

SHEET INDEX

SHEET NO.	SHEET TITLE
T-1	TITLE SHEET
A-1	OVERALL AND ENLARGED SITE PLANS
A-2	ELEVATION, ANTENNA LAYOUT AND SCHEDULE
A-3	EQUIPMENT PLATFORM AND H-FRAME DETAILS
A-4	EQUIPMENT DETAILS
A-5	EQUIPMENT DETAILS
A-6	EQUIPMENT DETAILS
E-1	ELECTRICAL/FIBER ROUTE PLAN AND NOTES
E-2	ELECTRICAL DETAILS
E-3	ELECTRICAL ONE-LINE, FAULT CALCS & PANEL SCHEDULE
G-1	GROUNDING PLANS AND NOTES
G-2	GROUNDING DETAILS
G-3	GROUNDING DETAILS
RF-1	RF CABLE COLOR CODE
GN-1	LEGEND AND ABBREVIATIONS
GN-2	GENERAL NOTES
GN-3	GENERAL NOTES
GN-4	GENERAL NOTES

SITE PHOTO



UNDERGROUND SERVICE ALERT - 811 DIG SAFE
UTILITY NOTIFICATION CENTER OF MASSACHUSETTS
(888) 344-7233
WWW.DIGSAFE.COM



CALL 3 WORKING DAYS UTILITY NOTIFICATION PRIOR TO CONSTRUCTION

GENERAL NOTES

THE FACILITY IS UNMANNED AND NOT FOR HUMAN HABITATION. A TECHNICIAN WILL VISIT THE SITE AS REQUIRED FOR ROUTINE MAINTENANCE. THE PROJECT WILL NOT RESULT IN ANY SIGNIFICANT DISTURBANCE OR EFFECT ON DRAINAGE. NO SANITARY SEWER SERVICE, POTABLE WATER, OR TRASH DISPOSAL IS REQUIRED AND NO COMMERCIAL SIGNAGE IS PROPOSED.

11"x17" PLOT WILL BE HALF SCALE UNLESS OTHERWISE NOTED

CONTRACTOR SHALL VERIFY ALL PLANS, EXISTING DIMENSIONS, AND CONDITIONS ON THE JOB SITE, AND SHALL IMMEDIATELY NOTIFY THE ENGINEER IN WRITING OF ANY DISCREPANCIES BEFORE PROCEEDING WITH THE WORK.

DIRECTIONS

DIRECTIONS FROM BOSTON LOGAN INTERNATIONAL AIRPORT:
START OUT GOING EAST ON RACE POINT RD. TURN RIGHT TO STAY ON RACE POINT RD. TURN LEFT ONTO ROUTE 6/US-6 W. CONTINUE TO FOLLOW US-6 W. 344 ROUTE 6, NORTH TRURO, MA 02652, 344 ROUTE 6 IS ON THE RIGHT.

VICINITY MAP

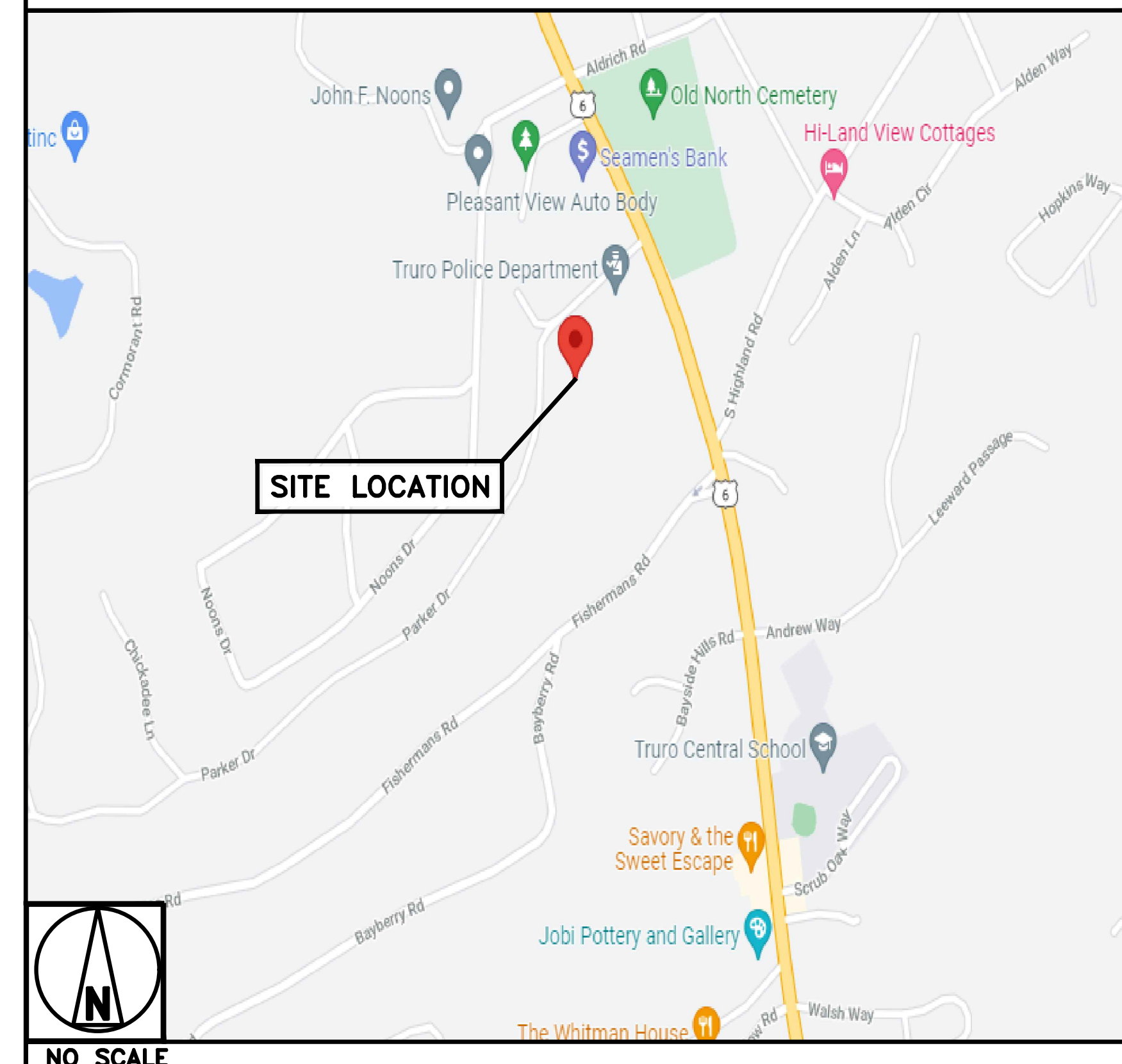

NOTES

1. CONTRACTOR SHALL FIELD VERIFY ALL DIMENSIONS.
2. ANTENNAS AND MOUNTS OMITTED FOR CLARITY.

NOTES

1. CONTRACTOR SHALL FIELD VERIFY ALL DIMENSIONS.
2. CONTRACTOR SHALL MAINTAIN A 10'-0" MINIMUM SEPARATION BETWEEN THE PROPOSED GPS UNIT, TRANSMITTING ANTENNAS AND EXISTING GPS UNITS.
3. ANTENNAS AND MOUNTS OMITTED FOR CLARITY.

dish
wireless.

5701 SOUTH SANTA FE DRIVE
LITTLETON, CO 80120

HG
HUDSON
Design Group LLC

45 BEECHWOOD DRIVE TEL: (978) 557-5553
N. ANDOVER, MA 01845 FAX: (978) 336-5586

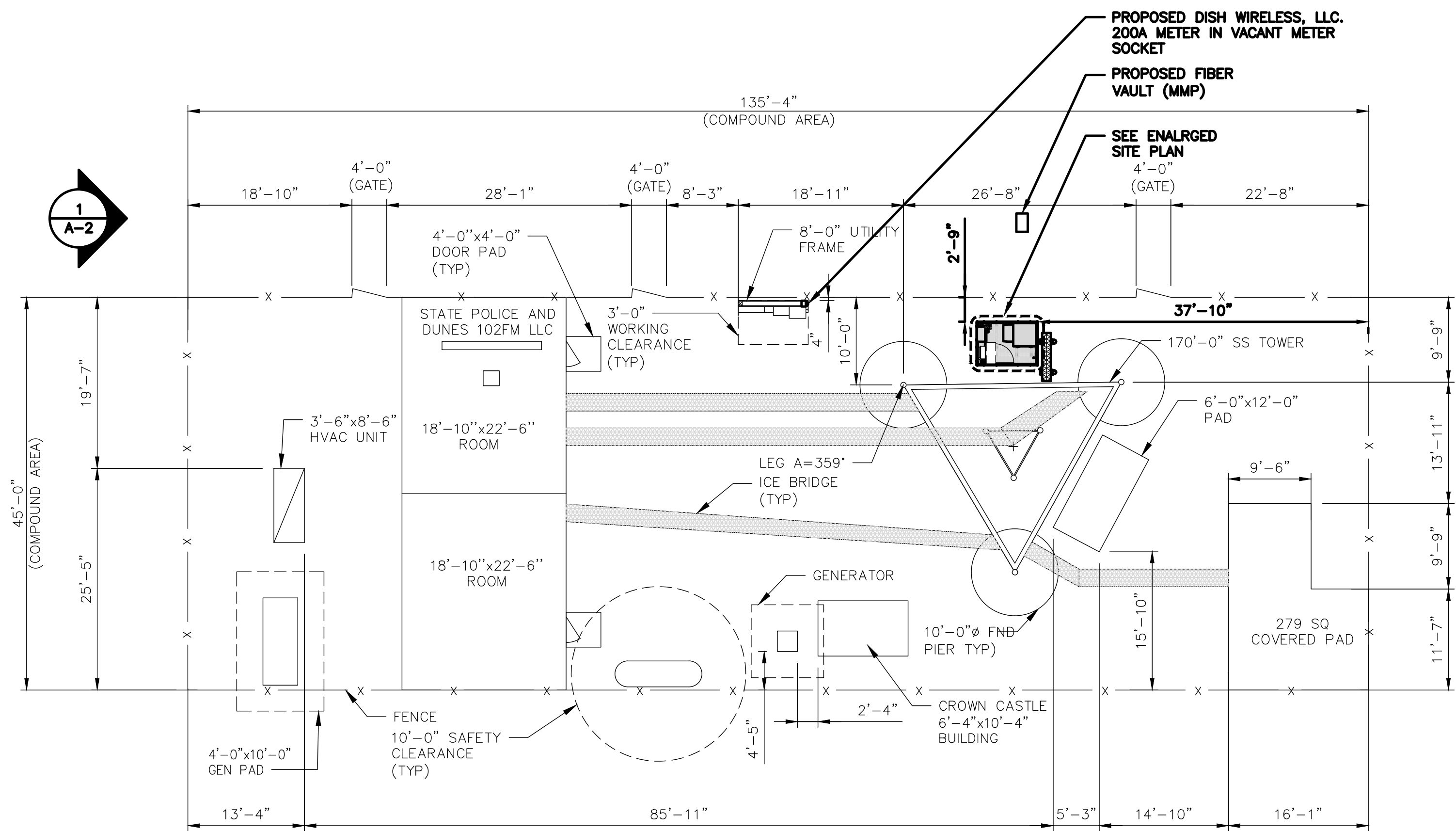

OVERALL SITE PLAN

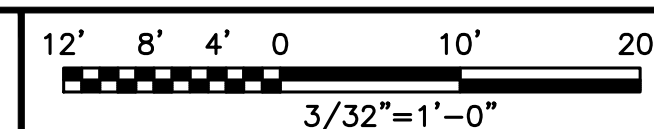

1

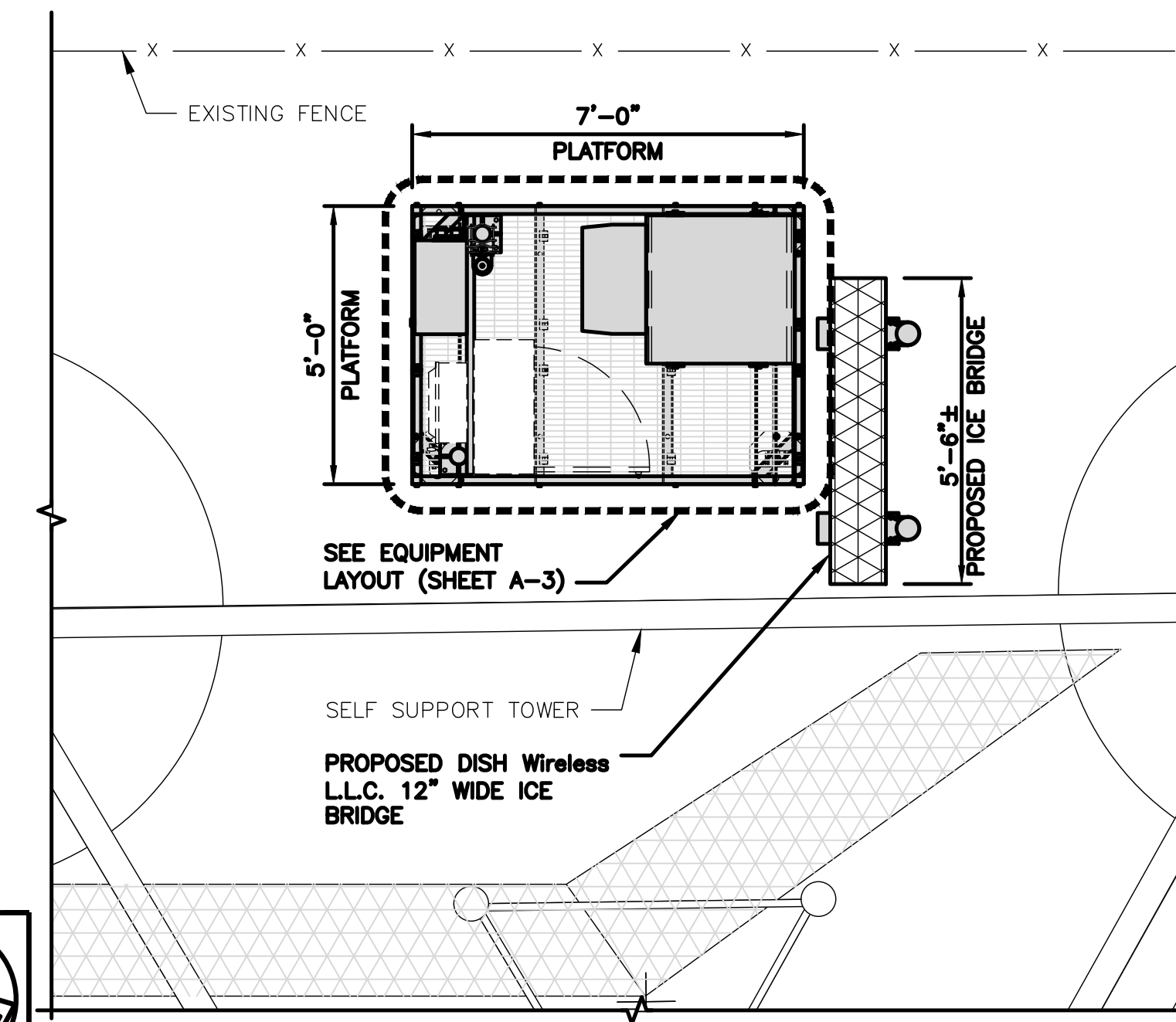

ENLARGED SITE PLAN

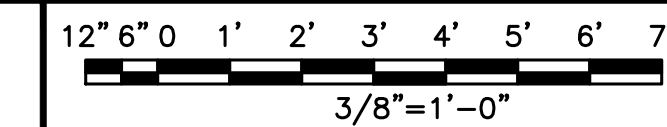

2



OVERALL UTILITY ROUTE PLAN

NO SCALE

3

IT IS A VIOLATION OF LAW FOR ANY PERSON, UNLESS THEY ARE ACTING UNDER THE DIRECTION OF A LICENSED PROFESSIONAL ENGINEER, TO ALTER THIS DOCUMENT.

DRAWN BY: PS CHECKED BY: SMA APPROVED BY: DPH

RFDS REV #: 0

PRELIMINARY DOCUMENTS

SUBMITTALS		
REV	DATE	DESCRIPTION
A	11/15/2021	ISSUED FOR REVIEW
B	01/21/2022	ISSUED FOR REVIEW

A&E PROJECT NUMBER
BOBOS00592A

DISH Wireless L.L.C.
PROJECT INFORMATION
BOBOS00592A
CROWN CASTLE BU#841273
344 ROUTE 6
NORTH TRURO, MA 02652

SHEET TITLE
OVERALL AND ENLARGED SITE PLANS

SHEET NUMBER
A-1

NOTES

1. CONTRACTOR SHALL FIELD VERIFY ALL DIMENSIONS.
2. ANTENNA AND MW DISH SPECIFICATIONS REFER TO ANTENNA SCHEDULE AND TO FINAL CONSTRUCTION RFDS FOR ALL RF DETAILS
3. EXISTING EQUIPMENT AND FENCE OMITTED FOR CLARITY.

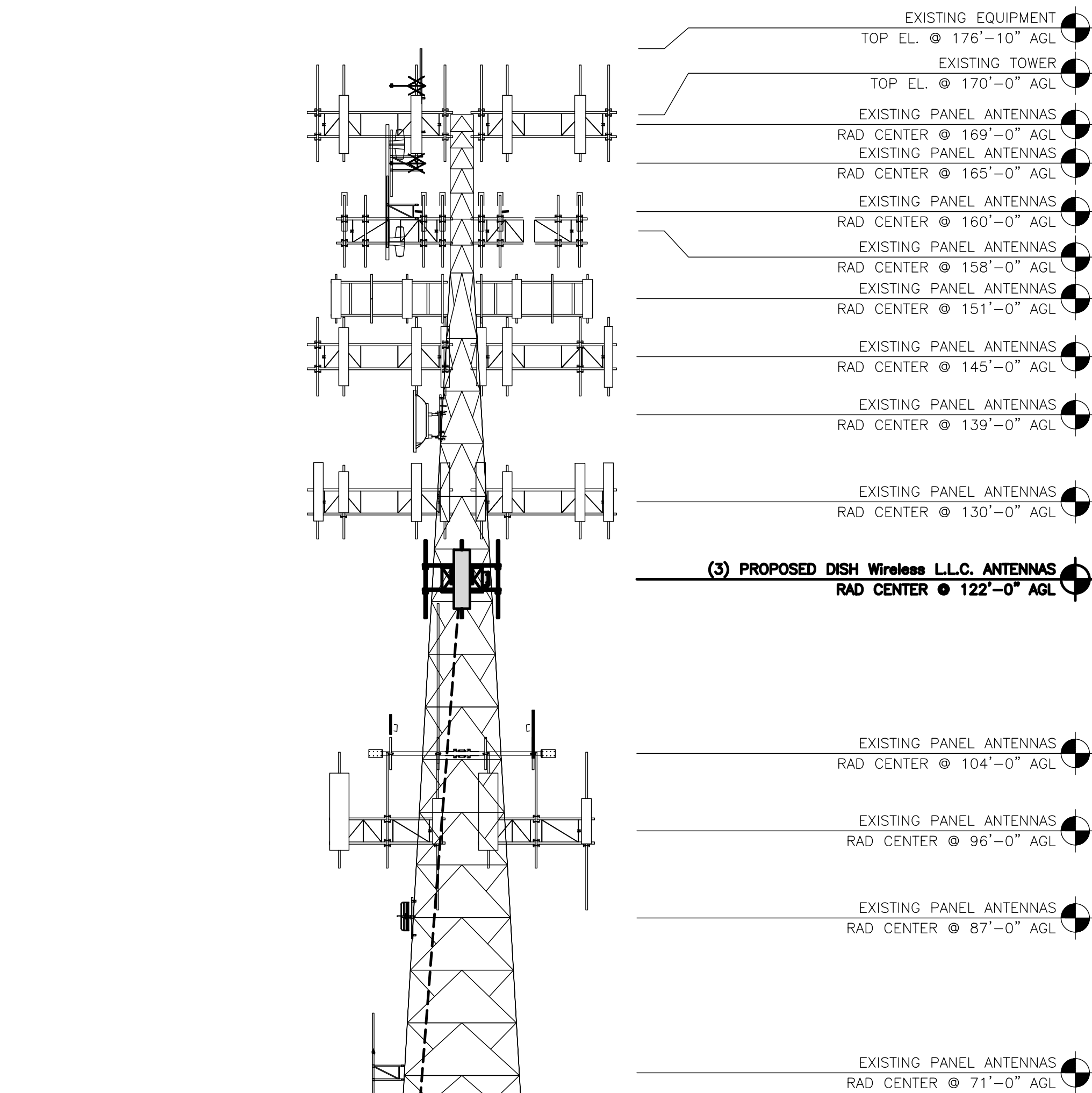

(1) PROPOSED DISH Wireless L.L.C. HYBRID CABLE ON NEW WAVEGUIDE LADDER

PROPOSED DISH Wireless L.L.C. ICE BRIDGE
 PROPOSED DISH Wireless L.L.C. GPS UNIT
 PROPOSED DISH Wireless L.L.C. EQUIPMENT ON PROPOSED STEEL PLATFORM

PROPOSED ELEVATION

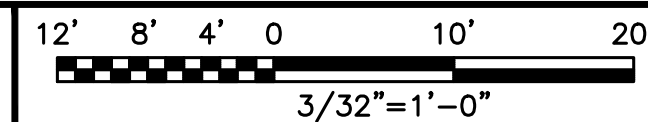

1

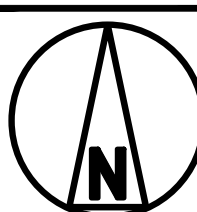
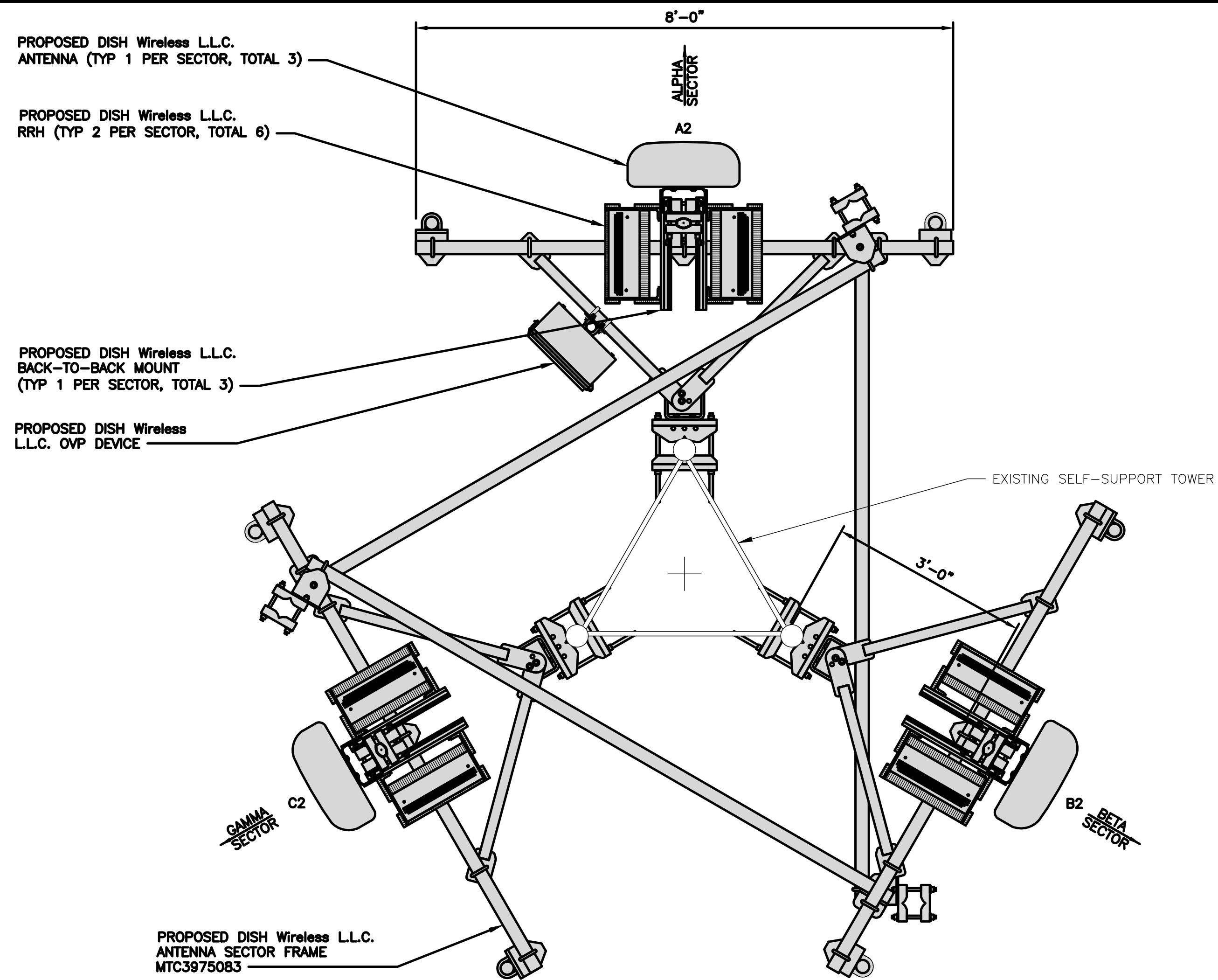

ANTENNA LAYOUT

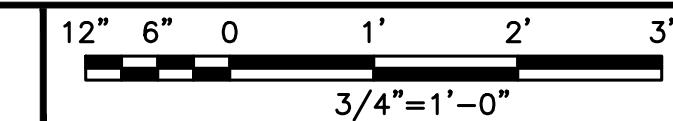

2

SECTOR POS.	ANTENNA					TRANSMISSION CABLE	RRH			OVP
	EXISTING OR PROPOSED	MANUFACTURER -- MODEL NUMBER	TECH	AZIMUTH	RAD CENTER		FEED LINE TYPE AND LENGTH	MANUFACTURER -- MODEL NUMBER	TECH	
A1	---	---	---	---	---	(1) HIGH-CAPACITY HYBRID CABLE (155' LONG)	FUJITSU / TA08025-B604	5G	A2	RAYCAP / RDIC-9181-PF-48
A2	PROPOSED	COMMSCOPE-FFW-65B-R2	5G	330'	122'-0"		FUJITSU / TA08025-B605	5G	A2	
A3	---	---	---	---	---		---	---	---	
B1	---	---	---	---	---	SHARED W/ALPHA	FUJITSU / TA08025-B604	5G	B2	SHARED W/ALPHA
B2	PROPOSED	COMMSCOPE-FFW-65B-R2	5G	80'	122'-0"		FUJITSU / TA08025-B605	5G	B2	
B3	---	---	---	---	---		---	---	---	
C1	---	---	---	---	---	SHARED W/ALPHA	FUJITSU / TA08025-B604	5G	C2	SHARED W/ALPHA
C2	PROPOSED	COMMSCOPE-FFW-65B-R2	5G	180'	122'-0"		FUJITSU / TA08025-B605	5G	C2	
C3	---	---	---	---	---		---	---	---	

- NOTES**
1. CONTRACTOR TO REFER TO FINAL CONSTRUCTION RFDS FOR ALL RF DETAILS.
 2. ANTENNA AND RRH MODELS MAY CHANGE DUE TO EQUIPMENT AVAILABILITY. ALL EQUIPMENT CHANGES MUST BE APPROVED AND REMAIN IN COMPLIANCE WITH THE PROPOSED DESIGN AND STRUCTURAL ANALYSES.

ANTENNA SCHEDULE

NO SCALE

3



5701 SOUTH SANTA FE DRIVE
LITTLETON, CO 80120



45 BEECHWOOD DRIVE TEL: (978) 557-5553
N. ANDOVER, MA 01845 FAX: (978) 336-5586

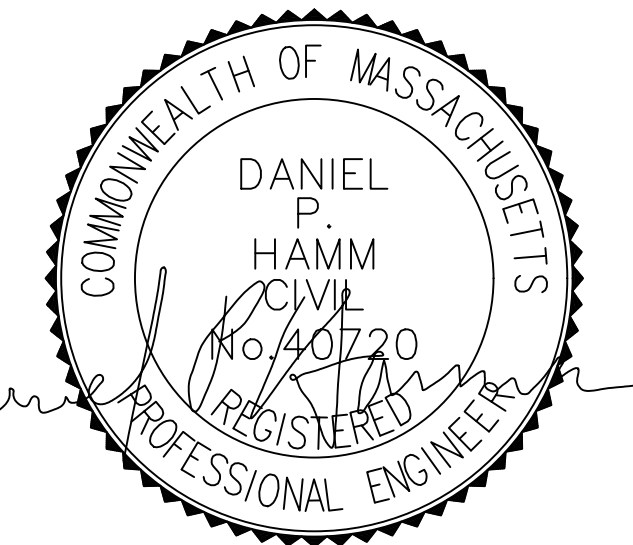

IT IS A VIOLATION OF LAW FOR ANY PERSON, UNLESS THEY ARE ACTING UNDER THE DIRECTION OF A LICENSED PROFESSIONAL ENGINEER, TO ALTER THIS DOCUMENT.

DRAWN BY: PS CHECKED BY: SMA APPROVED BY: DPH

RFDS REV #: 0

PRELIMINARY DOCUMENTS

SUBMITTALS		
REV	DATE	DESCRIPTION
A	11/15/2021	ISSUED FOR REVIEW
B	01/21/2022	ISSUED FOR REVIEW

A&E PROJECT NUMBER
BOBOS00592A

DISH Wireless L.L.C. PROJECT INFORMATION
BOBOS00592A
CROWN CASTLE BU#841273
344 ROUTE 6
NORTH TRURO, MA 02652

SHEET TITLE
ELEVATION, ANTENNA LAYOUT AND SCHEDULE

SHEET NUMBER
A-2



5701 SOUTH SANTA FE DRIVE
LITTLETON, CO 80120



45 BEECHWOOD DRIVE TEL: (978) 557-5553
N. ANDOVER, MA 01845 FAX: (978) 336-5586



IT IS A VIOLATION OF LAW FOR ANY PERSON, UNLESS THEY ARE ACTING UNDER THE DIRECTION OF A LICENSED PROFESSIONAL ENGINEER, TO ALTER THIS DOCUMENT.

DRAWN BY: PS CHECKED BY: SMA APPROVED BY: DPH

RFDS REV #: 0

PRELIMINARY DOCUMENTS

SUBMITTALS		
REV	DATE	DESCRIPTION
A	11/15/2021	ISSUED FOR REVIEW
B	01/21/2022	ISSUED FOR REVIEW

A&E PROJECT NUMBER
BOBOS00592A

DISH Wireless L.L.C. PROJECT INFORMATION
BOBOS00592A
CROWN CASTLE BU#841273
344 ROUTE 6
NORTH TRURO, MA 02652

SHEET TITLE
EQUIPMENT PLATFORM AND H-FRAME DETAILS

SHEET NUMBER

A-3

NOTES

1. CONTRACTOR TO BURY PLATFORM FEET WITH A MINIMUM OF 2" OF FILL PER EXISTING SITE SURFACE
2. WEED BARRIER FABRIC TO BE ADDED AT DISCRETION OF DISH Wireless L.L.C. CONSTRUCTION MANAGER AT TIME OF CONSTRUCTION. ONE SHEET 8'x8' INSTALLED UNDER ALL FOUR FEET OF THE PLATFORM (4 MIL BLACK PLASTIC)
3. EQUIPMENT CABINET OMITTED FOR CLARITY

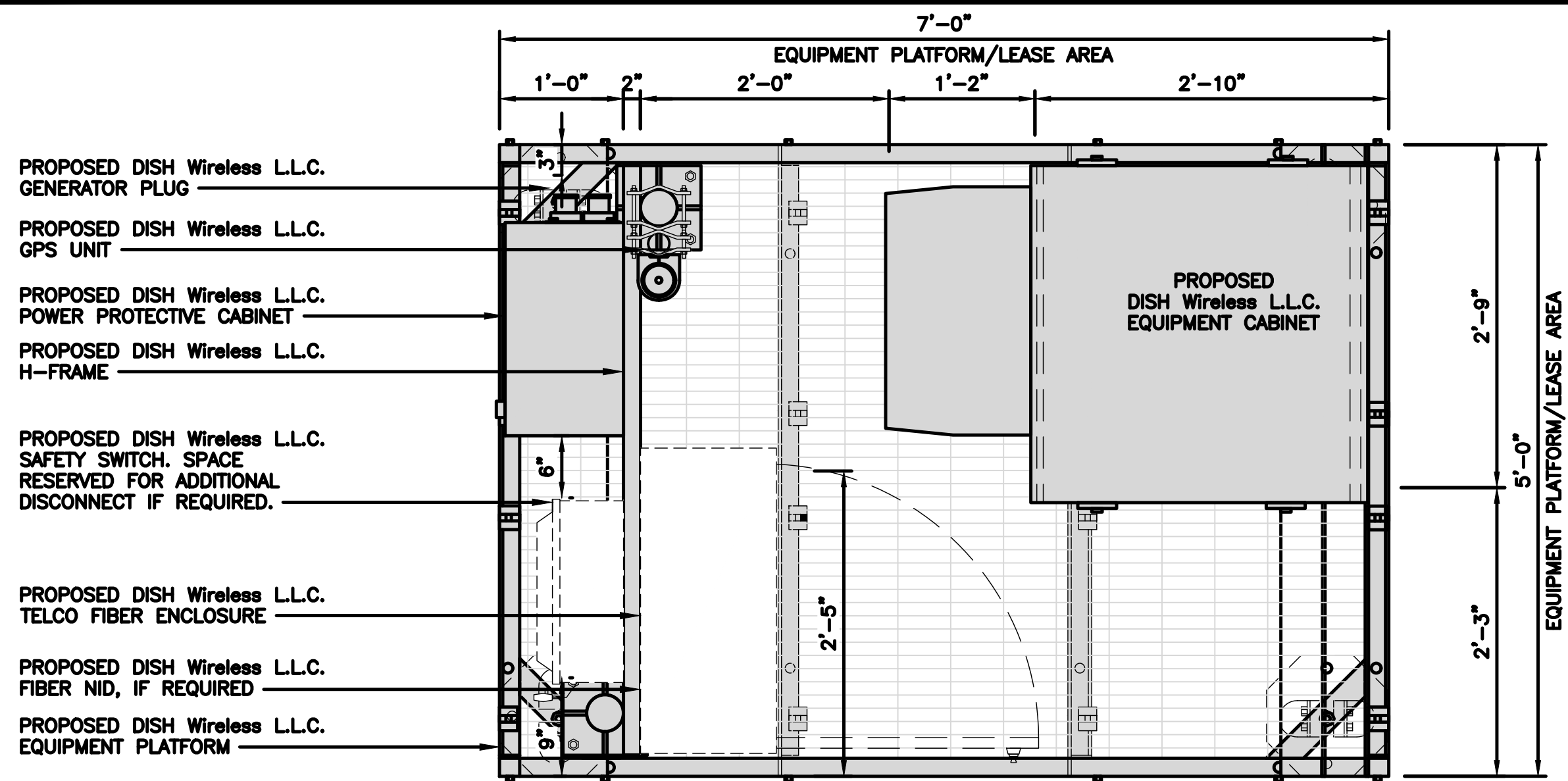

PLATFORM EQUIPMENT PLAN

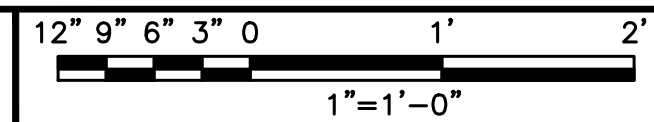

1

COMMSCOPE MTC4045LP 5X7 PLATFORM	
DIMENSIONS (HxWxD)	16"x84"x60"
TOTAL WEIGHT	423 LBS

NOTE:
GC TO PROVIDE EXTENDED THREAD FOR PLATFORM IF REQUIRED HEIGHT EXCEEDS 17"

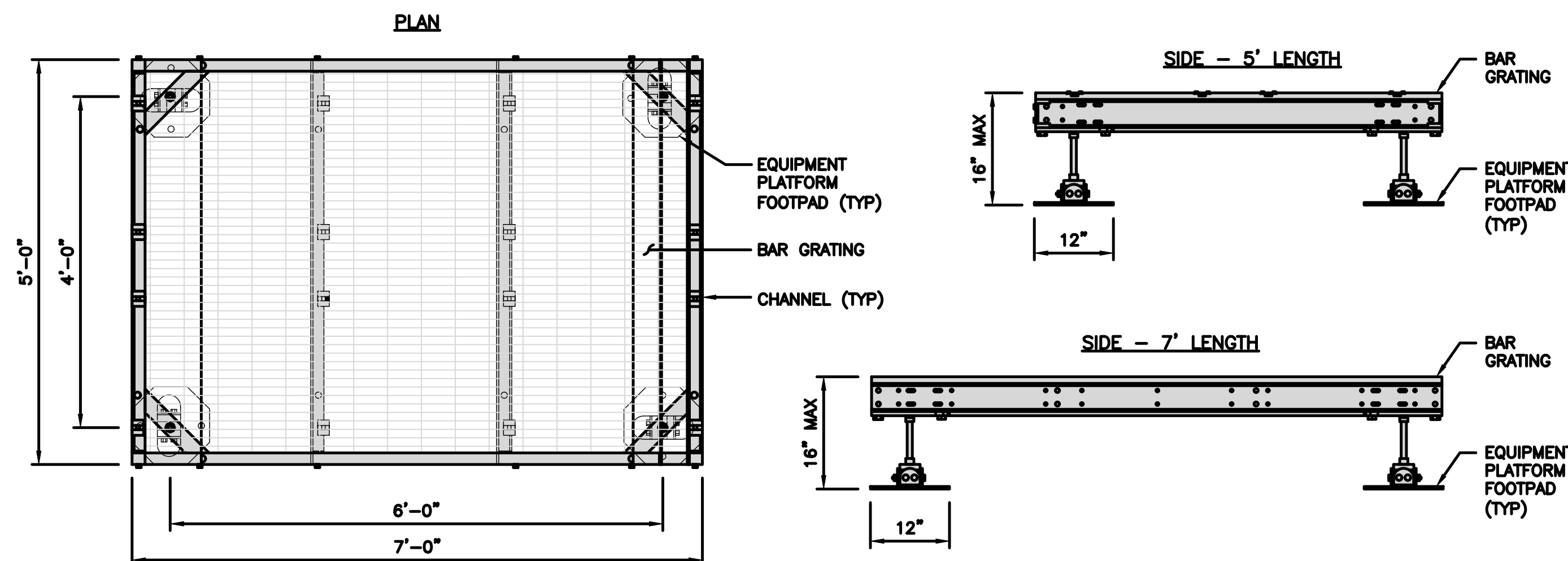

PLATFORM DETAIL

NO SCALE 2

COMMSCOPE MTC4045HFLD H-FRAME	
UNISTRUT/SUPPORT RAILS QTY	5
WEIGHT	59.74 lbs

NOTE:
OR DISH Wireless L.L.C. APPROVED EQUIVALENT

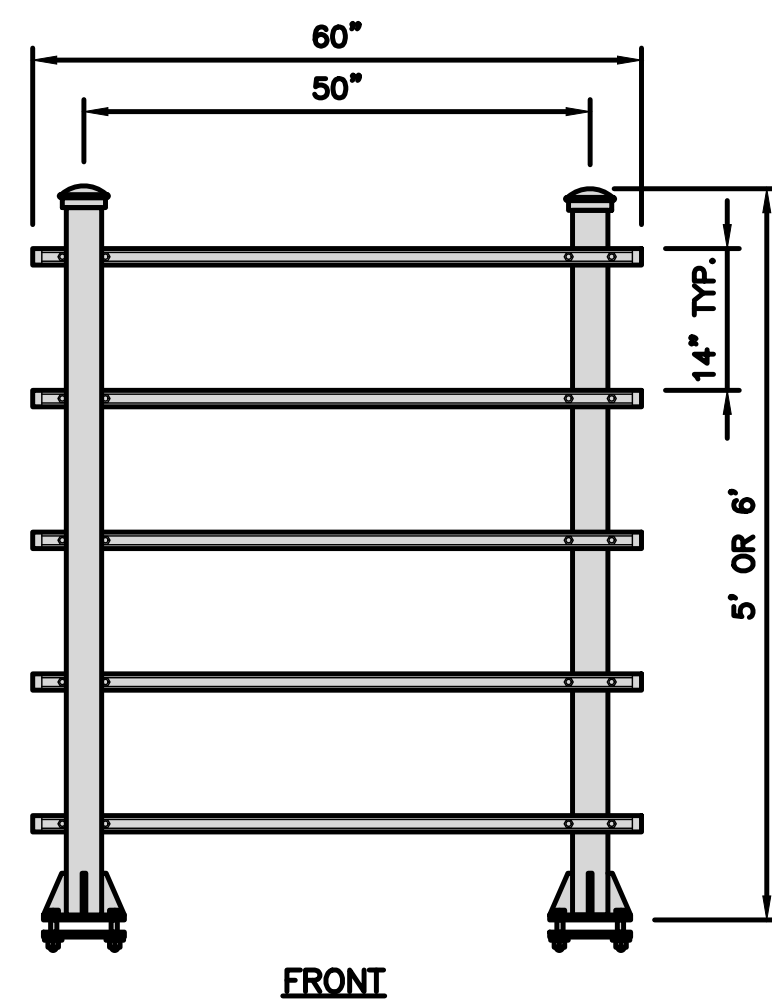
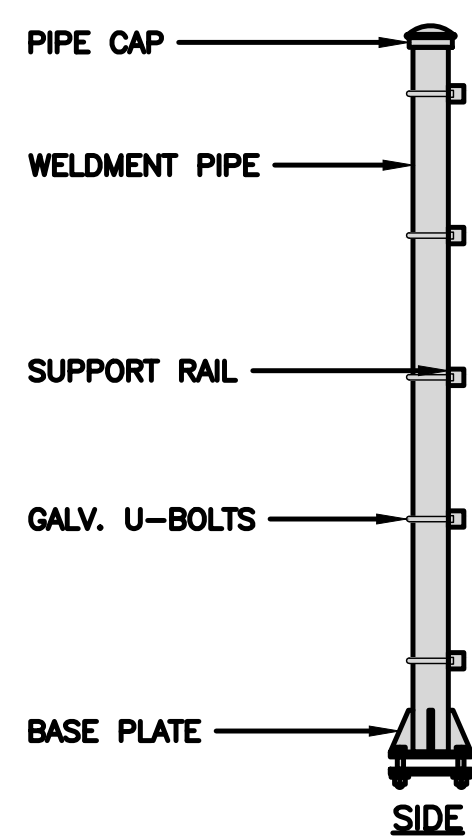

H-FRAME DETAIL

NO SCALE 3

NOT USED

NO SCALE 4

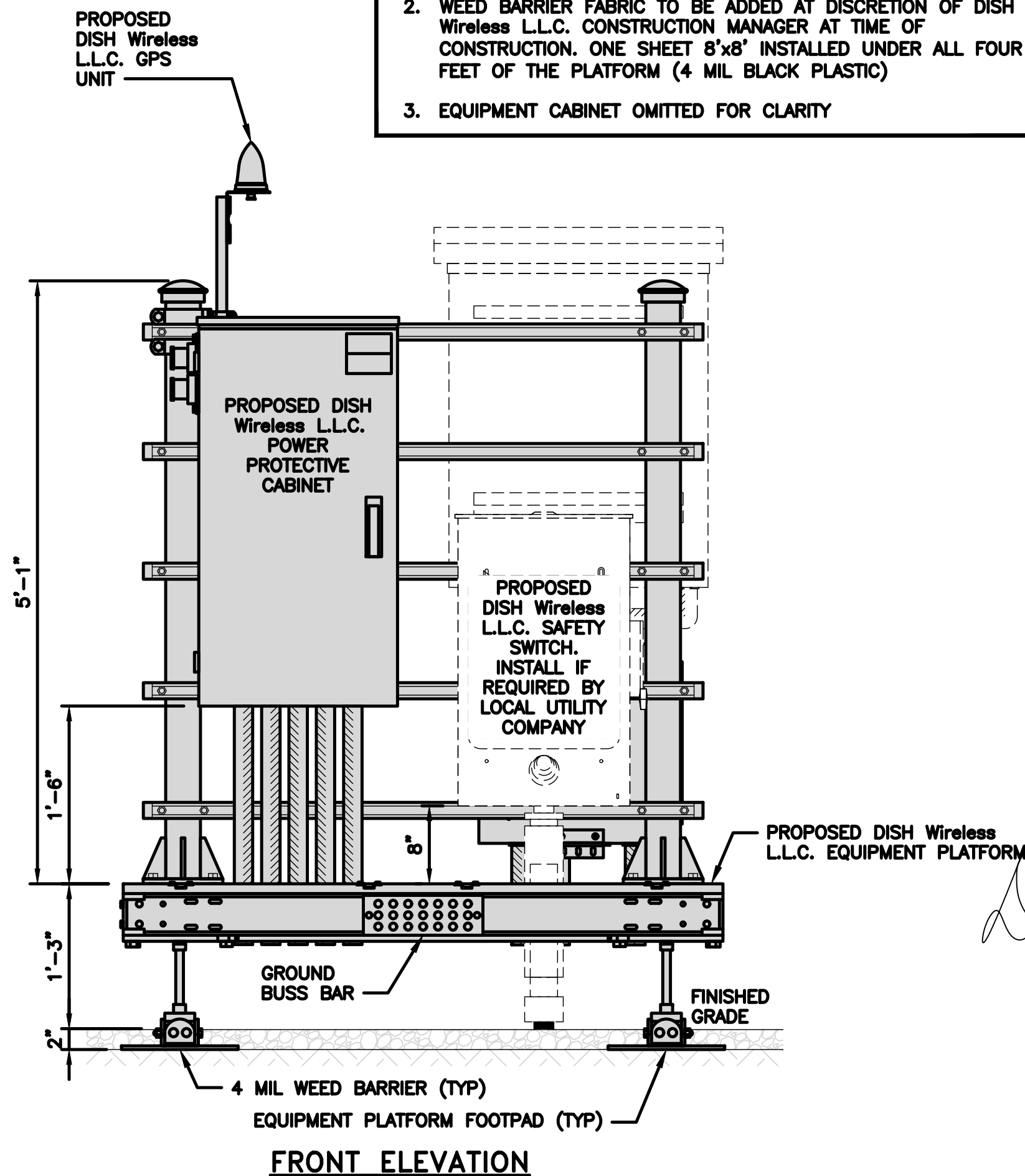

FRONT ELEVATION

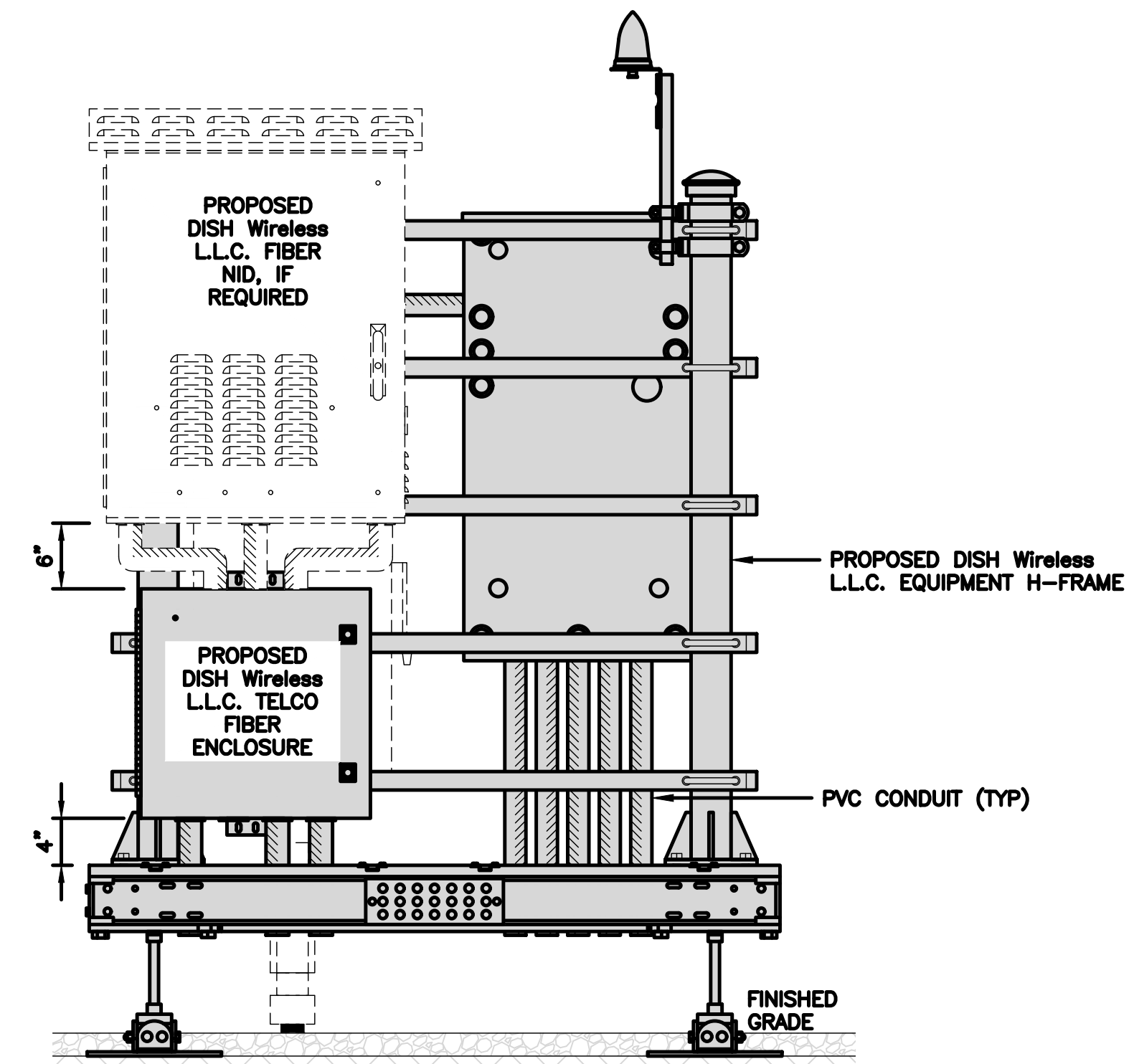

BACK ELEVATION

H-FRAME EQUIPMENT ELEVATION

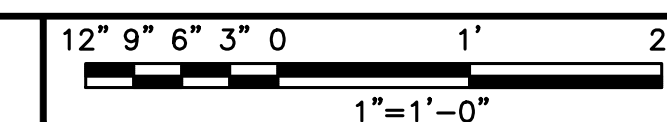

5

CHARLES INDUSTRY HEX CUBE-PM639155N4	
DIMENSIONS (HxWxD)	74"x32"x32"
POWER PLANT	-48VDC ABB/600W
TOTAL WEIGHT (EMPTY)	408 lbs

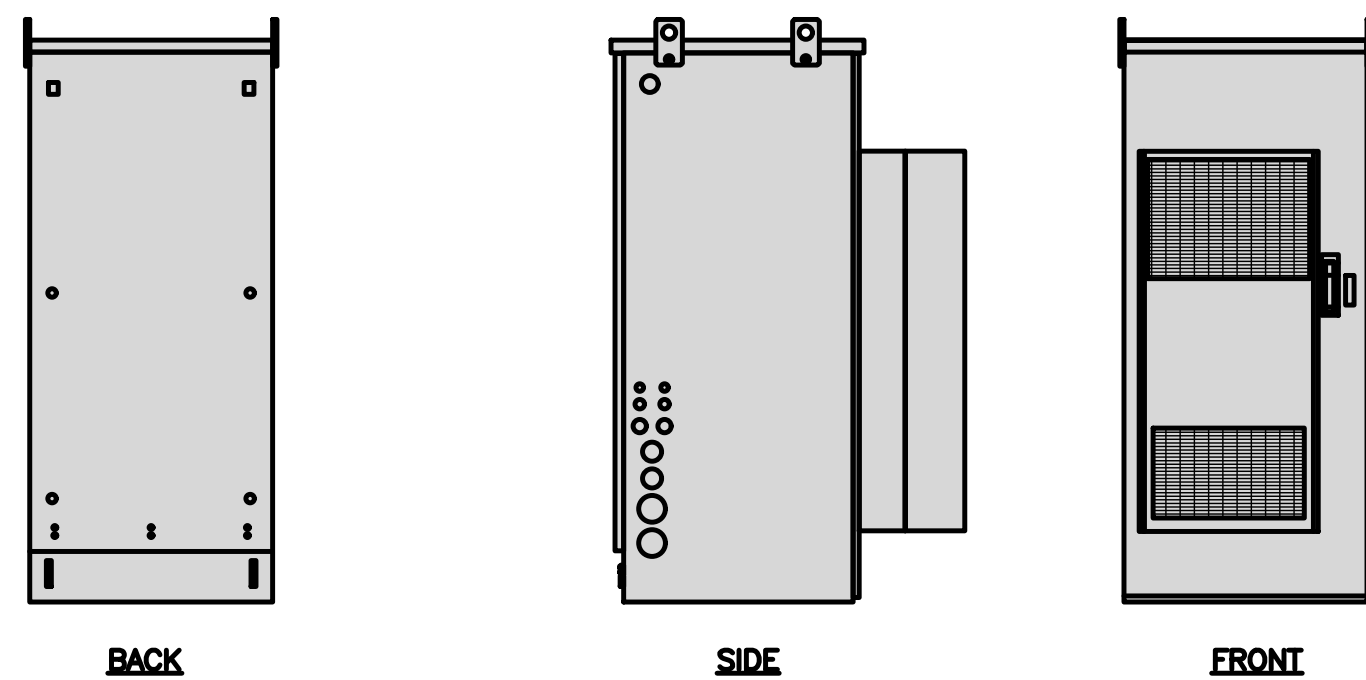
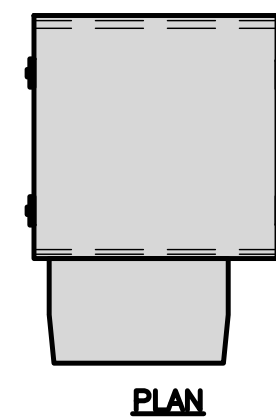

CABINET DETAIL

NO SCALE

1

RAYCAP PPC RDIAC-2465-P-240-MTS	
ENCLOSURE DIMENSIONS (HxWxD)	39"x22.855"x12.593
WEIGHT:	80 lbs
OPERATING AC VOLTAGE	240/120 1 PHASE 3W+G

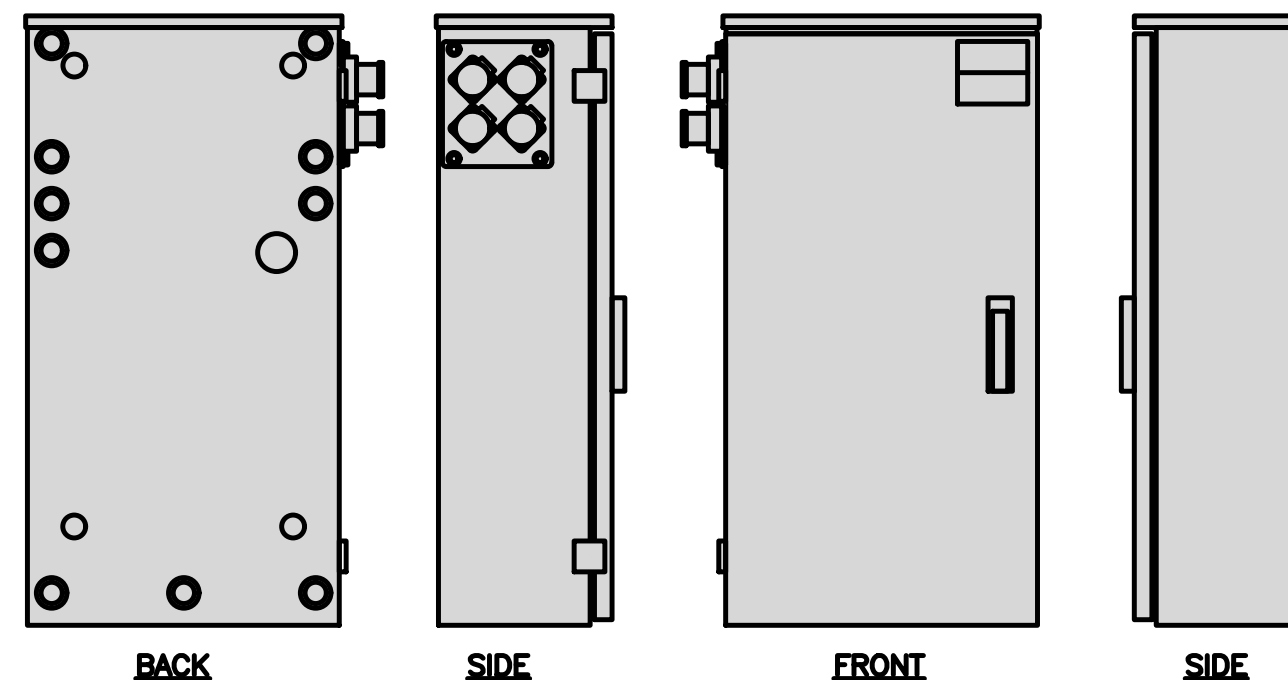
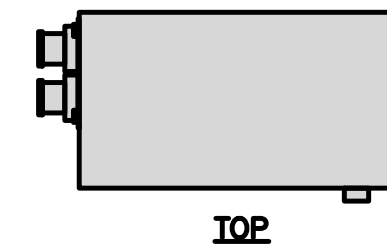

POWER PROTECTION CABINET (PPC) DETAIL

NO SCALE

2

SQUARE D SAFETY SWITCHES D224NRB	
ENCLOSURE DIM (HxWxD)	29.25"x19.00"x8.50"
ENCLOSURE TYPE	NEMA 3R RAINPROOF
UL LISTED	FILE E-2875

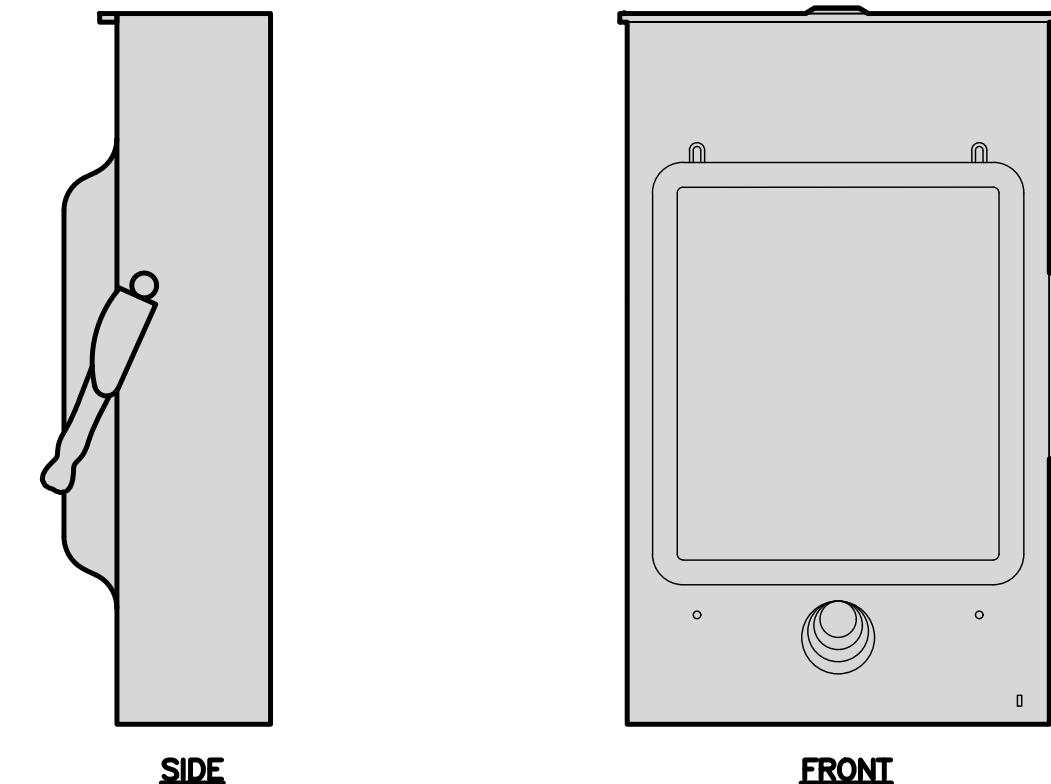
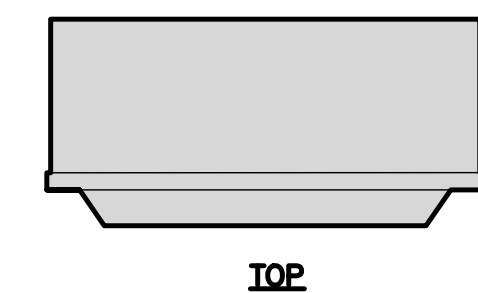

SAFETY SWITCH DETAIL

NO SCALE

3

ZAYO 5RU (LEFT SWING DOOR) FIBER NID ENCLOSURE	
DIMENSIONS (HxWxD)	36.1"x29"x12.9"
WEIGHT	85 lbs

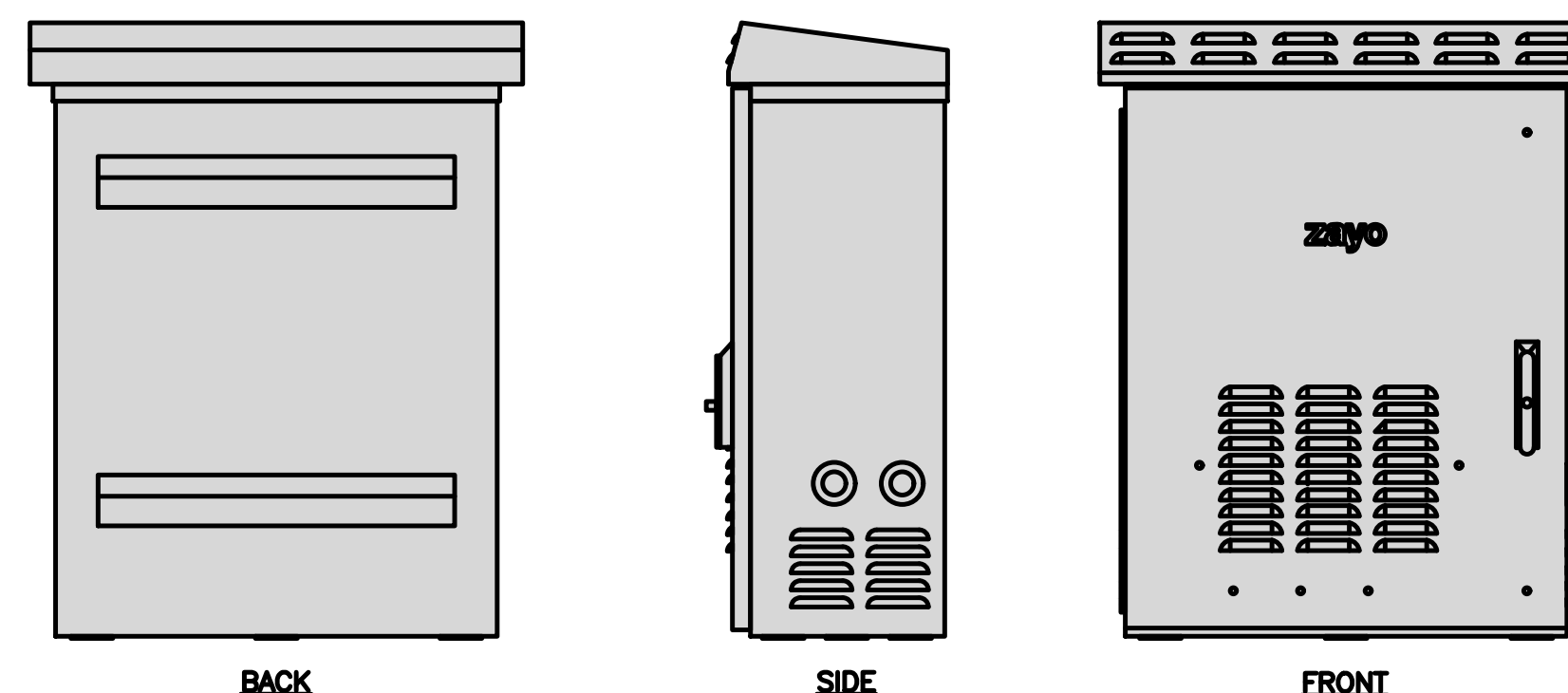
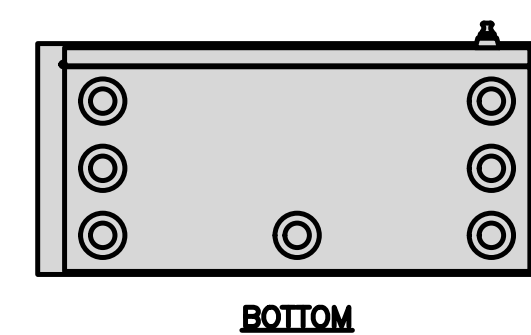

FIBER NID ENCLOSURE DETAIL

NO SCALE

5

CHARLES CFIT-PF2020DSH1 FIBER TELCO ENCLOSURE	
ENCLOSURE DIMS (HxWxD)	20"x20"x9"
ENCLOSURE WEIGHT	20 lbs
MOUNTING	WALL
COMPLIANCE	TYPE 4

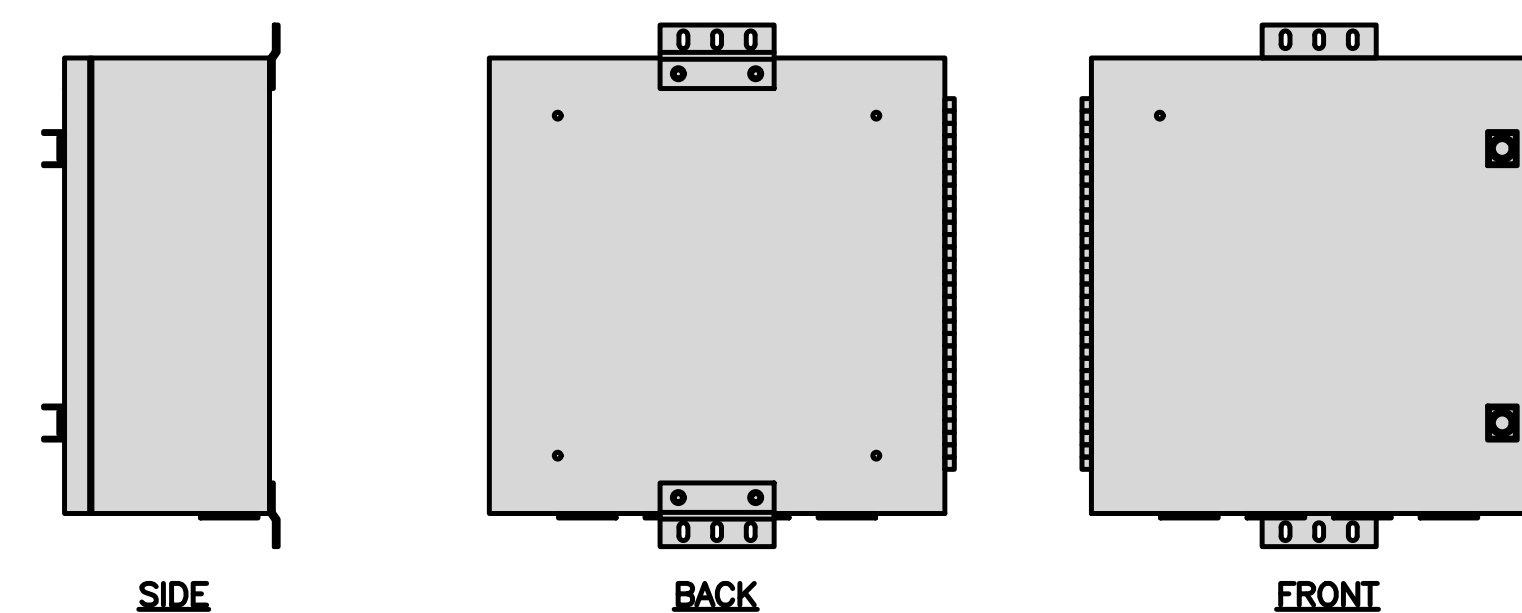
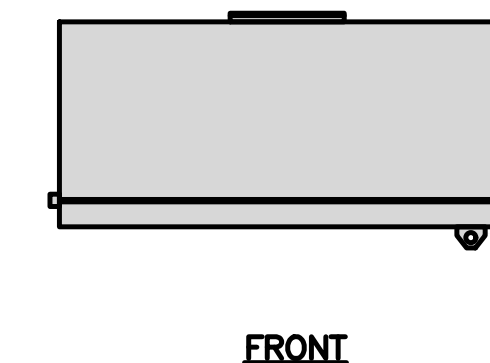

FIBER TELCO ENCLOSURE DETAIL

NO SCALE

6

COMMSCOPE WB-K110-B WAVEGUIDE BRIDGE KIT		INCLUDED PRODUCTS:	WB-T12-3 TRAPEZE KIT, 3 RUNGS
DIMENSIONS (HxL)	160"x10'		WB-LB12-3 SUPPORT BRACKET
WEIGHT/ VOLUME	325.0 LBS		MF-130 DIRECT BURIAL PIPE COLUMN, 13'-4"
CABLE RUN (QTY)	12		

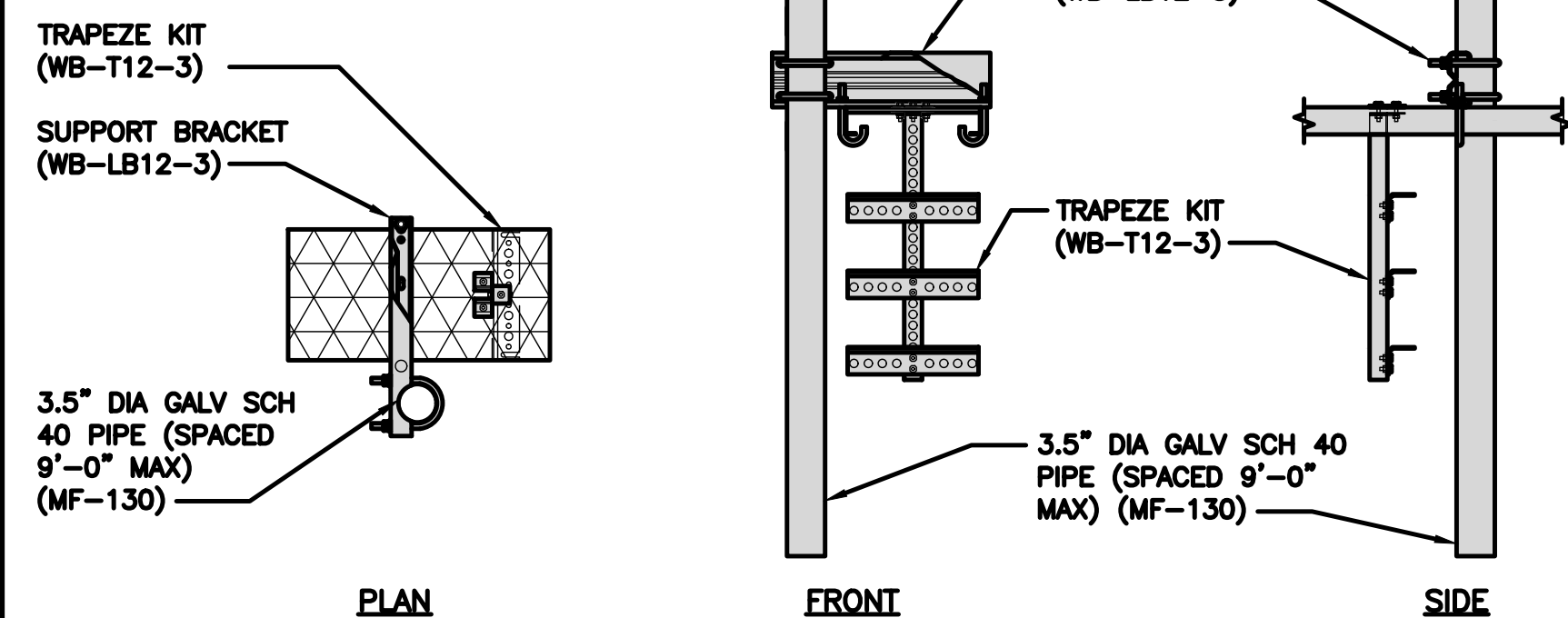

ICE BRIDGE DETAIL

NO SCALE

7

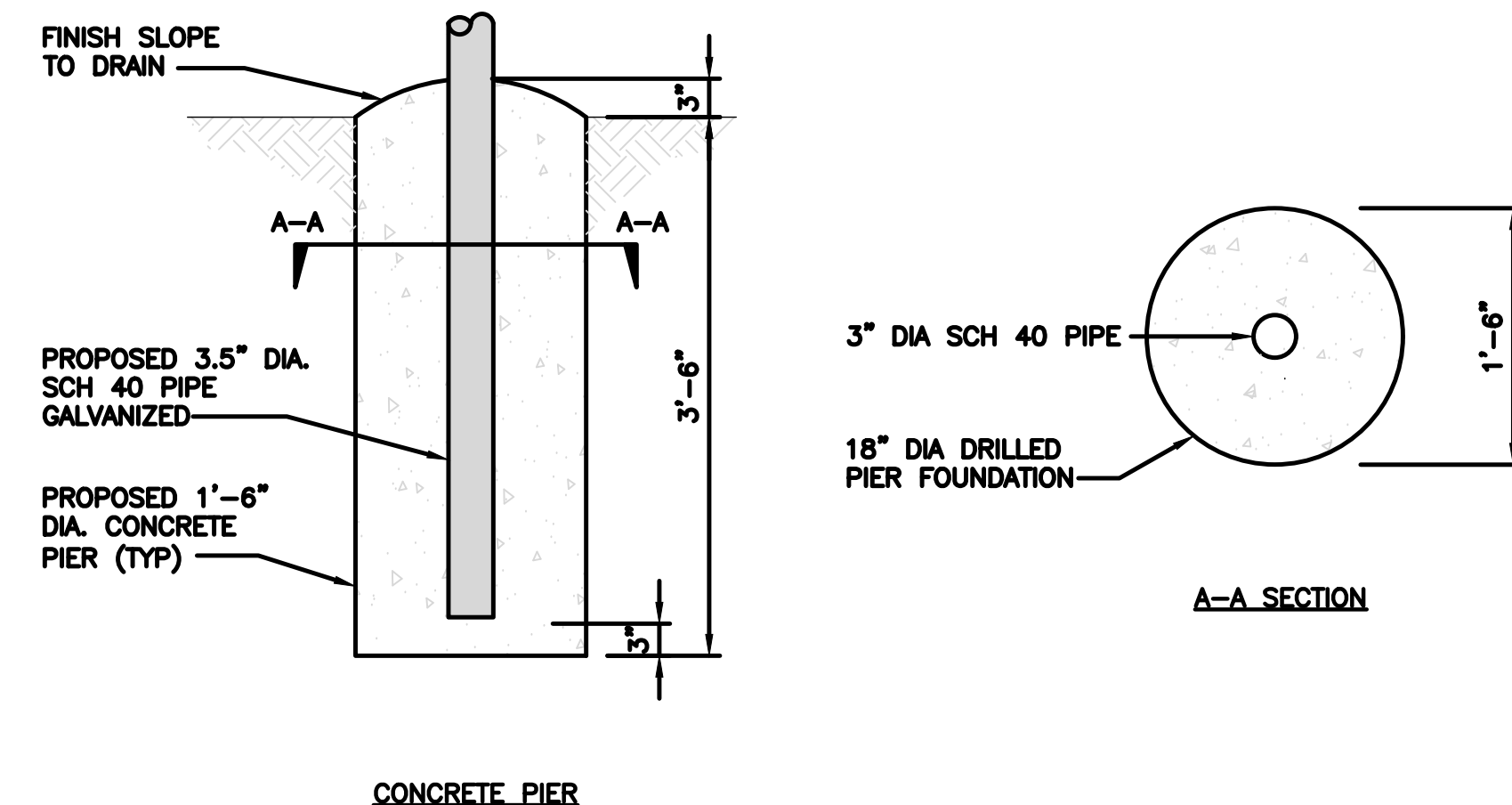

TYPICAL ICE BRIDGE CONCRETE PIER DETAIL

NO SCALE

8

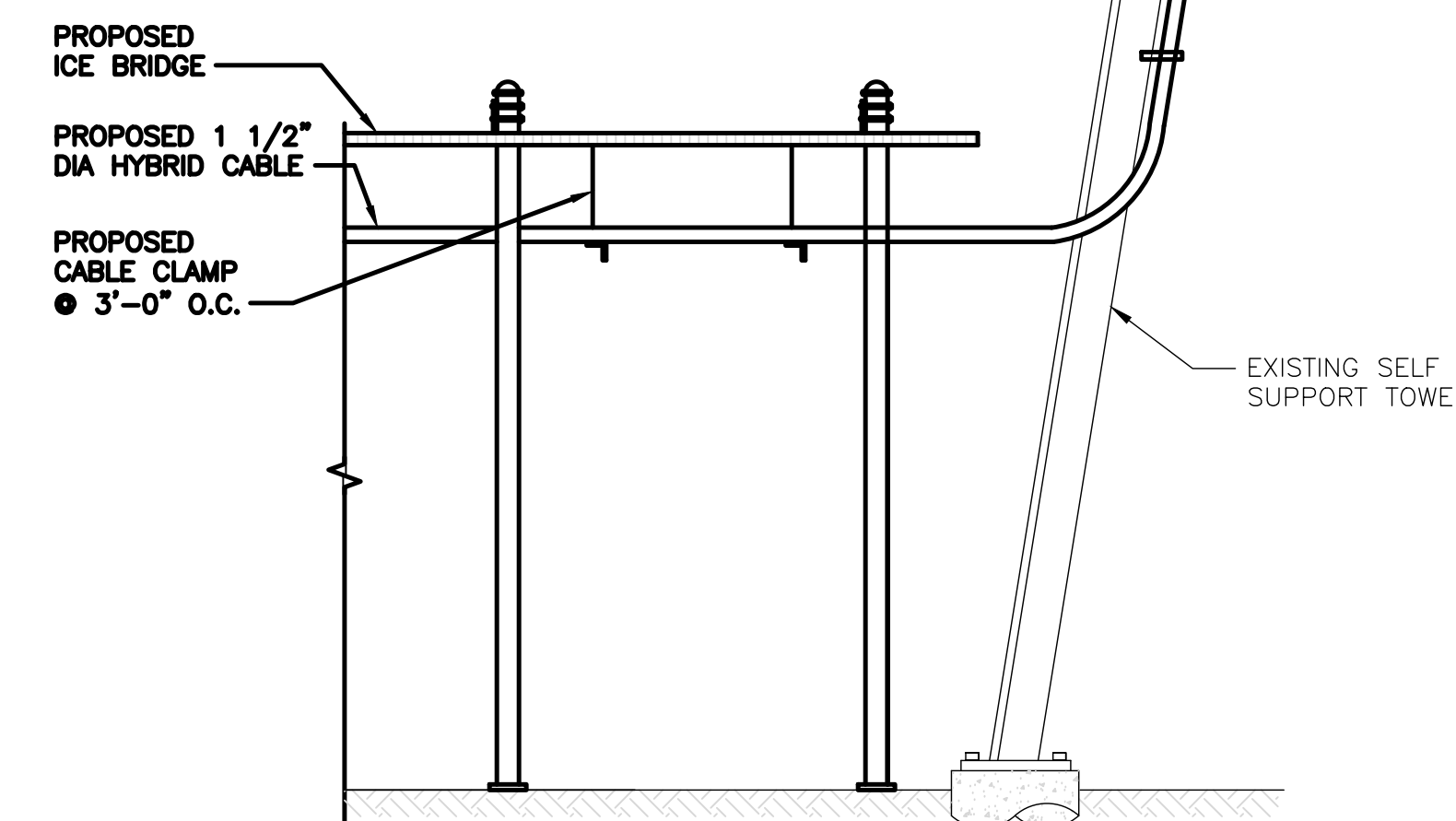

HYBRID CABLE RUN

NO SCALE

9

dish wireless.

5701 SOUTH SANTA FE DRIVE
LITTLETON, CO 80120

HG HUDSON Design Group LLC

45 BEECHWOOD DRIVE N. ANDOVER, MA 01845 TEL: (978) 557-5553 FAX: (978) 336-5586

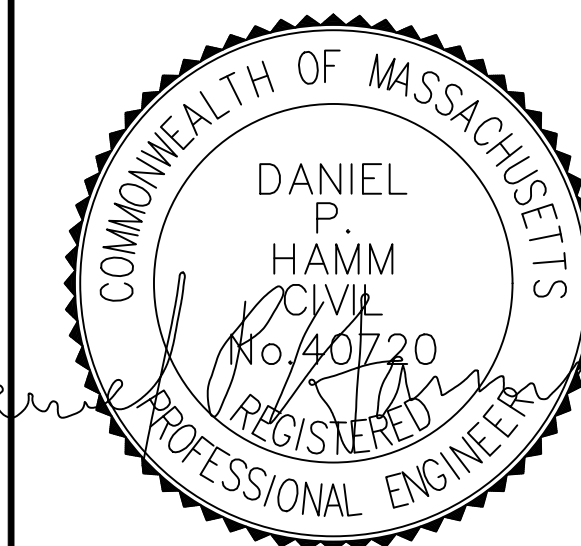

IT IS A VIOLATION OF LAW FOR ANY PERSON, UNLESS THEY ARE ACTING UNDER THE DIRECTION OF A LICENSED PROFESSIONAL ENGINEER, TO ALTER THIS DOCUMENT.

DRAWN BY: PS CHECKED BY: SMA APPROVED BY: DPH

RFDS REV #: 0

PRELIMINARY DOCUMENTS

SUBMITTALS		
REV	DATE	DESCRIPTION
A	11/15/2021	ISSUED FOR REVIEW
B	01/21/2022	ISSUED FOR REVIEW

A&E PROJECT NUMBER
BOBOS00592A

DISH Wireless L.L.C.
PROJECT INFORMATION
BOBOS00592A
CROWN CASTLE BU#841273
344 ROUTE 6
NORTH TRURO, MA 02652

SHEET TITLE
EQUIPMENT DETAILS

SHEET NUMBER
A-4

PCTEL GPSGL-TMG-SPI-40NCB	
DIMENSIONS (DIAxH) MM/INCH	81x184mm 3.2"x7.25"
WEIGHT W/ACCESSORIES	075 lbs
CONNECTOR	N-FEMALE
FREQUENCY RANGE	1590 ± 30MHz

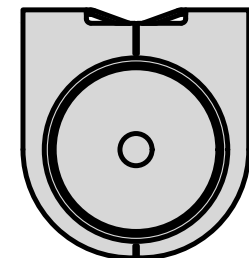

TOP

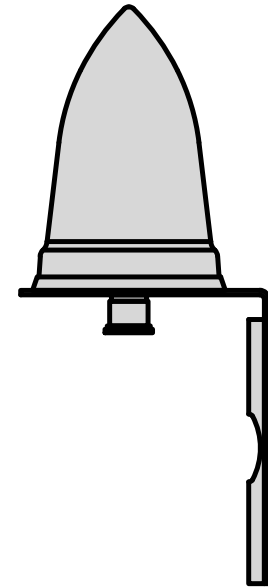

BACK

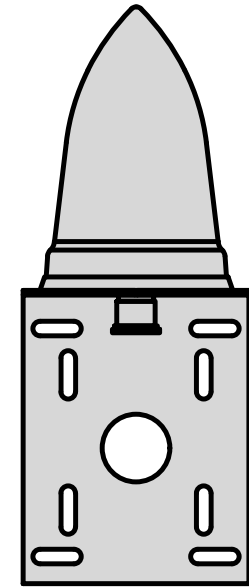

SIDE

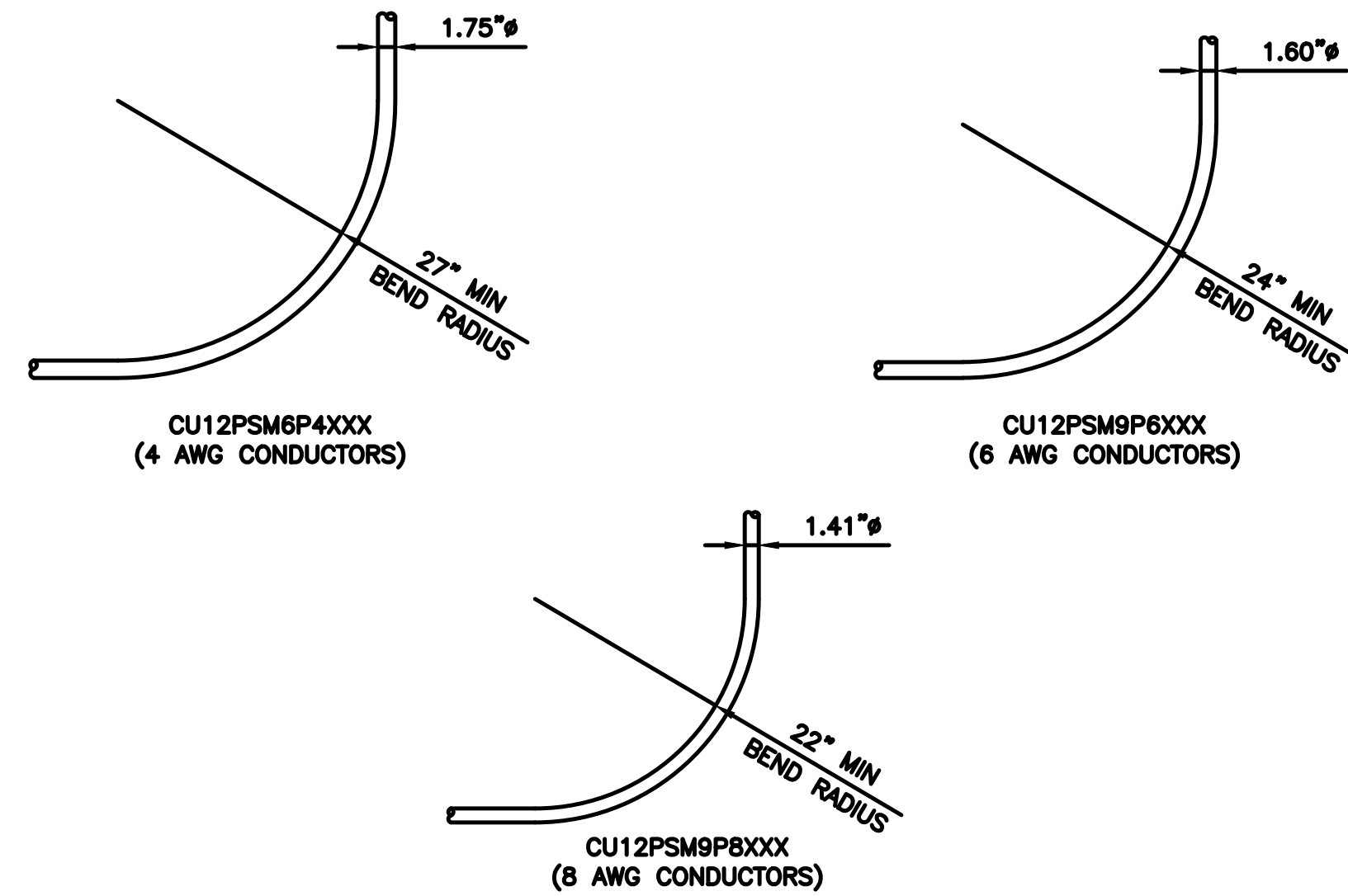
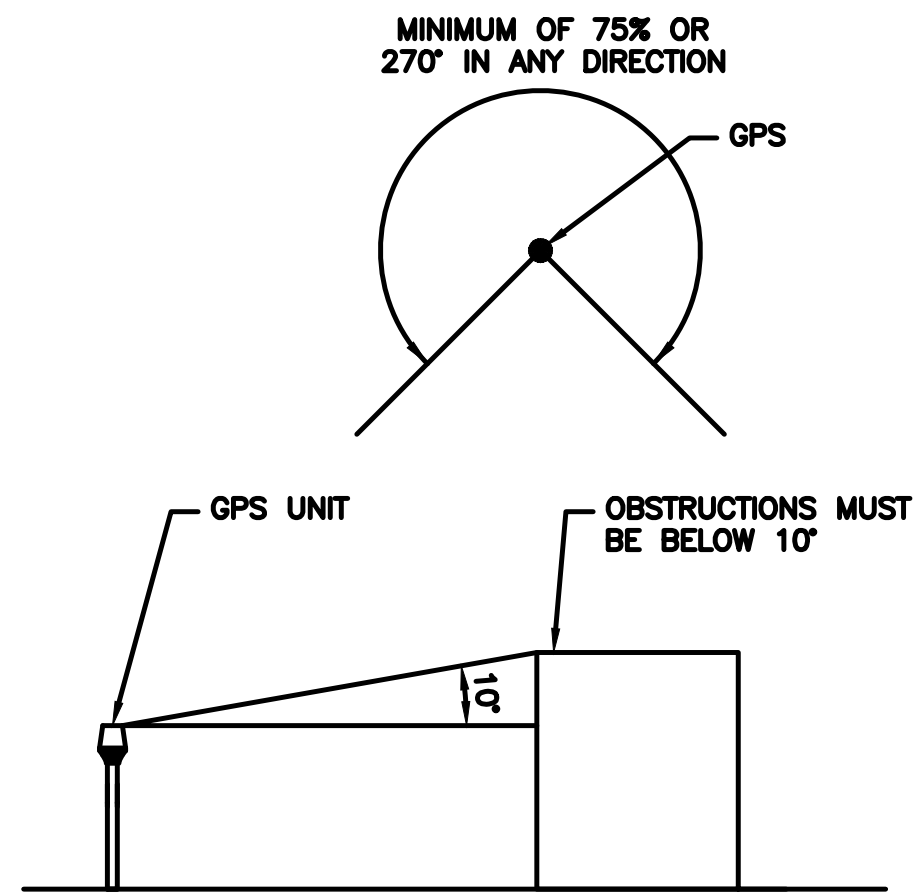

dish
wireless.

5701 SOUTH SANTA FE DRIVE
LITTLETON, CO 80120

HG
HUDSON
Design Group LLC

45 BEECHWOOD DRIVE TEL: (978) 557-5553
N. ANDOVER, MA 01845 FAX: (978) 336-5586



IT IS A VIOLATION OF LAW FOR ANY PERSON,
UNLESS THEY ARE ACTING UNDER THE DIRECTION
OF A LICENSED PROFESSIONAL ENGINEER,
TO ALTER THIS DOCUMENT.

DRAWN BY: PS CHECKED BY: SMA APPROVED BY: DPH

RFDS REV #: 0

**PRELIMINARY
DOCUMENTS**

SUBMITTALS		
REV	DATE	DESCRIPTION
A	11/15/2021	ISSUED FOR REVIEW
B	01/21/2022	ISSUED FOR REVIEW

A&E PROJECT NUMBER
BOBOS00592A

DISH Wireless L.L.C.
PROJECT INFORMATION
BOBOS00592A
CROWN CASTLE BU#841273
344 ROUTE 6
NORTH TRURO, MA 02652

SHEET TITLE
EQUIPMENT DETAILS

SHEET NUMBER
A-5

GPS DETAIL

NO SCALE

1

GPS MINIMUM SKY VIEW REQUIREMENTS

NO SCALE

2

CABLES UNLIMITED HYBRID CABLE
MINIMUM BEND RADIUSES

NO SCALE

3

NOT USED

NO SCALE

4

NOT USED

NO SCALE

5

NOT USED

NO SCALE

6

NOT USED

NO SCALE

7

NOT USED

NO SCALE

8

NOT USED

NO SCALE

9

FUJITSU TRIPLE BAND TA08025-B605	
DIMENSIONS (HxWxD)	14.9"x15.7"x9"
WEIGHT	74.95 lbs
CONNECTOR TYPE	4.3-10 RF CONNECTOR
POWER SUPPLY	DC -58~-36V

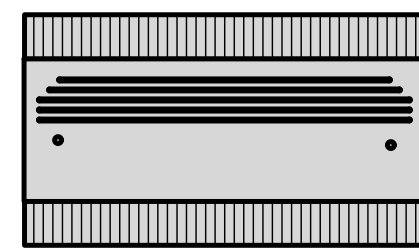

PLAN

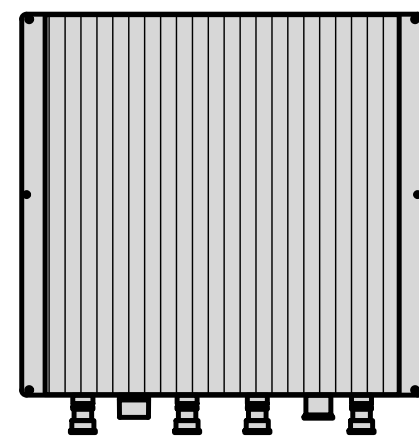

BACK

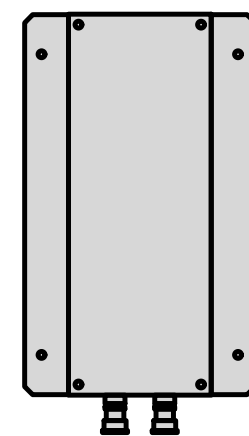

SIDE

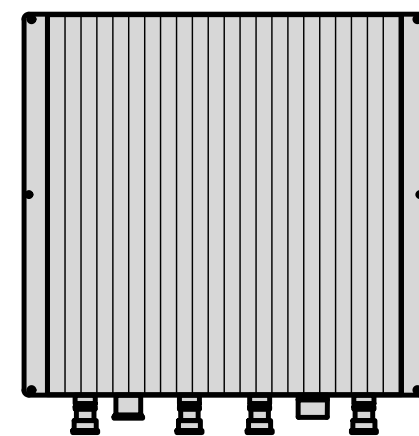

FRONT

RRH DETAIL

NO SCALE

1

FUJITSU DUAL BAND TA08025-B604	
DIMENSIONS (HxWxD)	14.9"x15.7"x7.8"
WEIGHT	63.9 lbs
CONNECTOR TYPE	4.3-10 RF CONNECTOR
POWER SUPPLY	DC -58~-36V

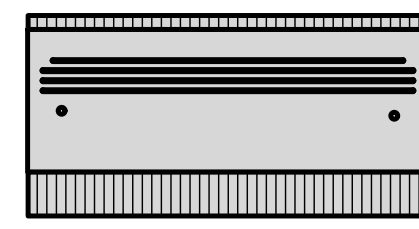

PLAN

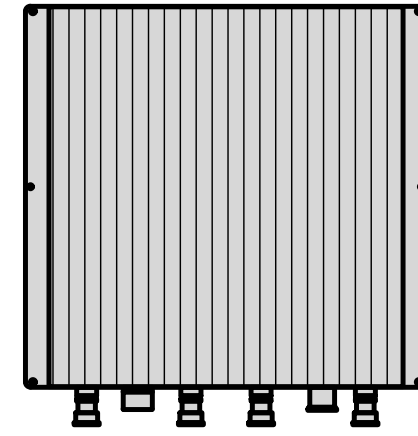

BACK

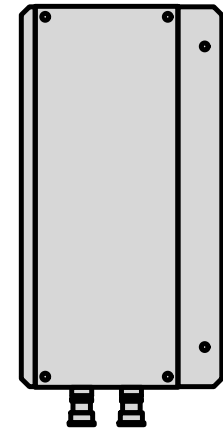

SIDE

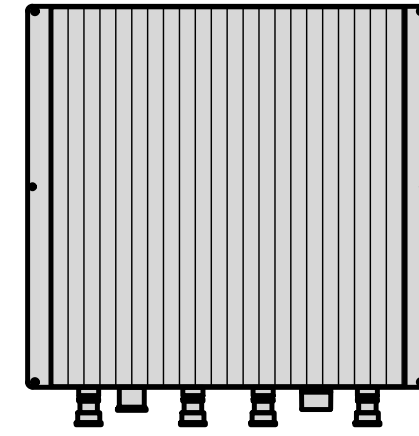

FRONT

RRH DETAIL

NO SCALE

2

SABRE DOUBLE Z-BRACKET C10123155	
DIMENSIONS (HxWxD) (1 BRACKET)	5"x20"x1-13/16"
WEIGHT (FULL ASSEMBLY)	35.79 lbs
PACKAGE QUANTITY	4

#	DESCRIPTION
1	PLATE, CHANNEL BRACKET
2	RRH Z BRACKET, 3/16"
3	THREADED ROD ASSEMBLY 1/2"x12"

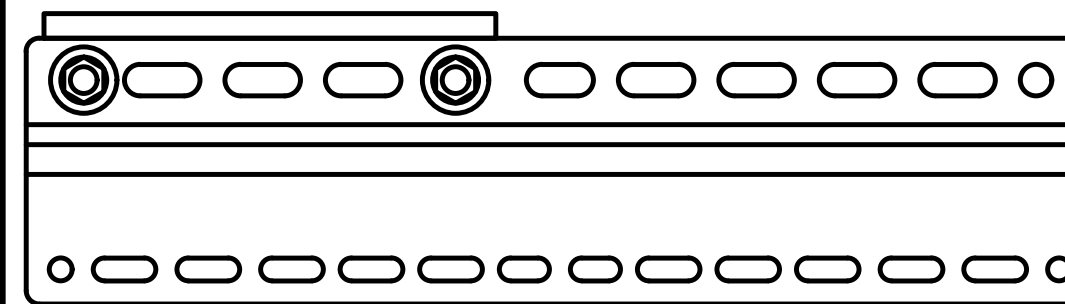

NOTE:
OR DISH Wireless L.L.C.
APPROVED EQUIVALENT

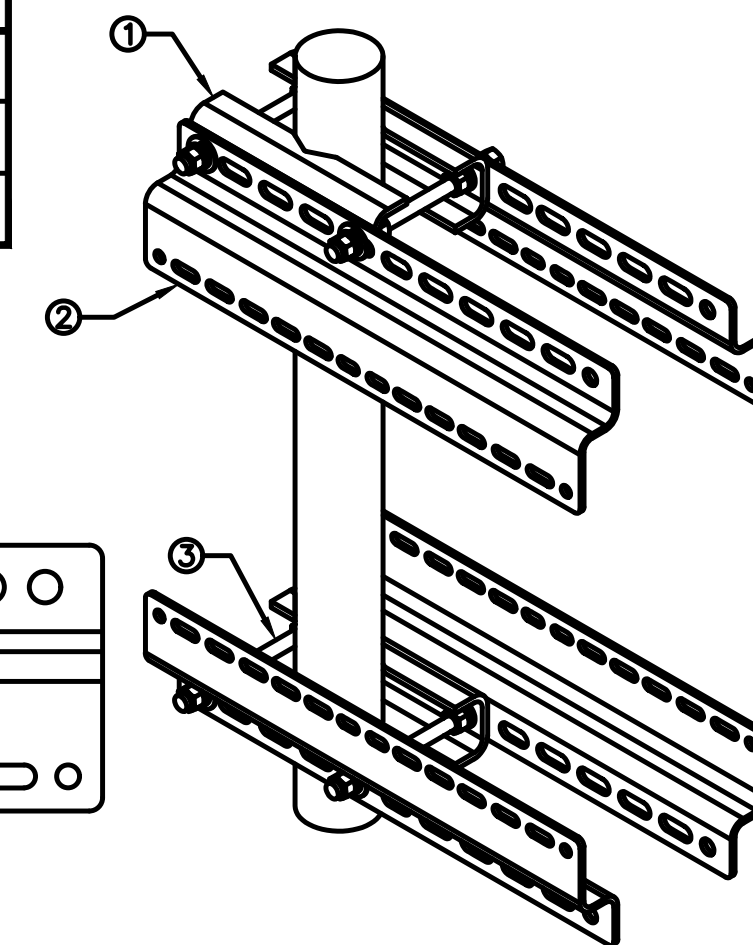

RRH MOUNT DETAIL

NO SCALE

3

COMMSCOPE FFVV-65B-R2	
DIMENSIONS (HxWxD)(MM/IN)	1826x498x197 72"x19.6"x7.8"
RF CONNECTOR INTERFACE	4.3-10 FEMALE
WEIGHT	70.8 lbs
WEIGHT WITH BRACKETS	98.1 lbs

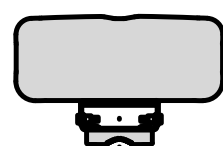

PLAN

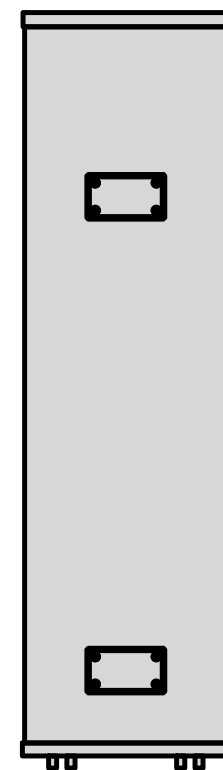

BACK

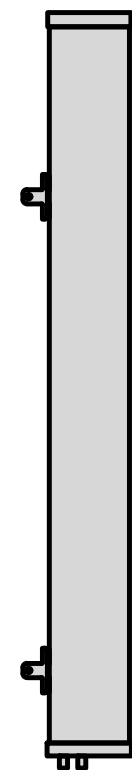

SIDE

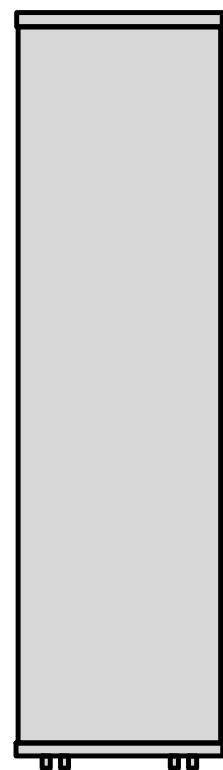

FRONT

ANTENNA DETAIL

NO SCALE

4

RAYCAP RDIC-9181-PF-48 DC SURGE PROTECTION (OVP)	
DIMENSIONS (HxWxD)	18.98"x14.39"x8.15"
WEIGHT	21.82 LBS

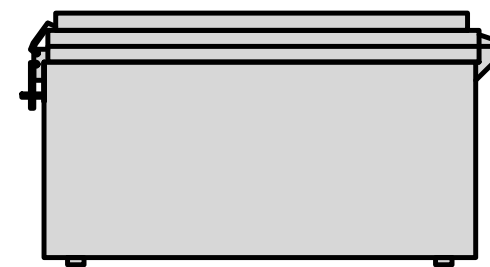

PLAN

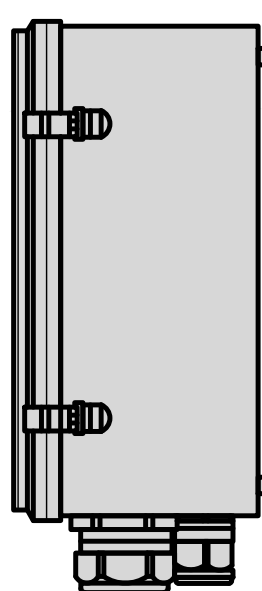

SIDE

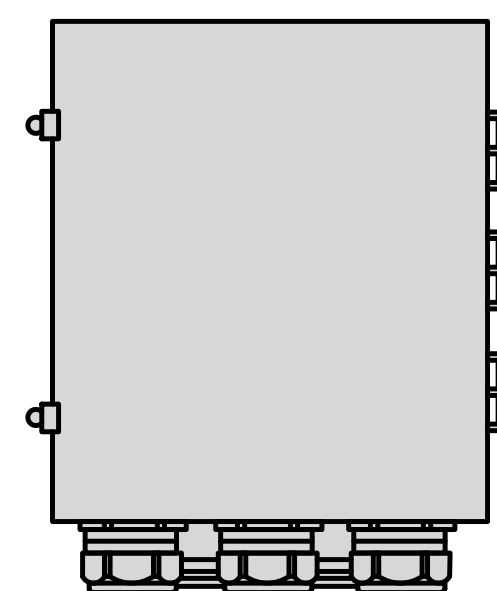

BACK

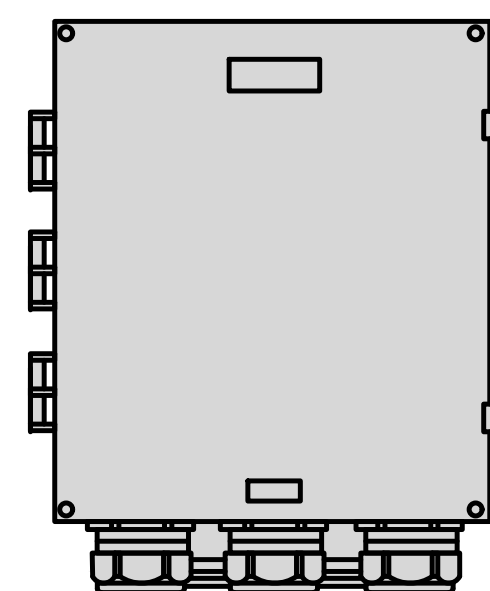

FRONT

SURGE SUPPRESSION DETAIL (OVP)

NO SCALE

7

COMMSCOPE 10' CABLE LADDER 6 HOLE RUNGS	
DIMENSIONS (WxL)	20.5"x120"
WEIGHT	43.65 lbs

ITEM#	DESCRIPTION
1	10' ANGLE SIDE RAIL
2	20" LADDER RUNG
3	BACKING PLATE
4	3/8"x1-1/2" GALV BOLT KIT
5	8" GALV J-BOLT KIT
6	3/8" GALV FLAT WASHER
7	3/8" GALV LOCK WASHER
8	3/8" GALV HEX NUT

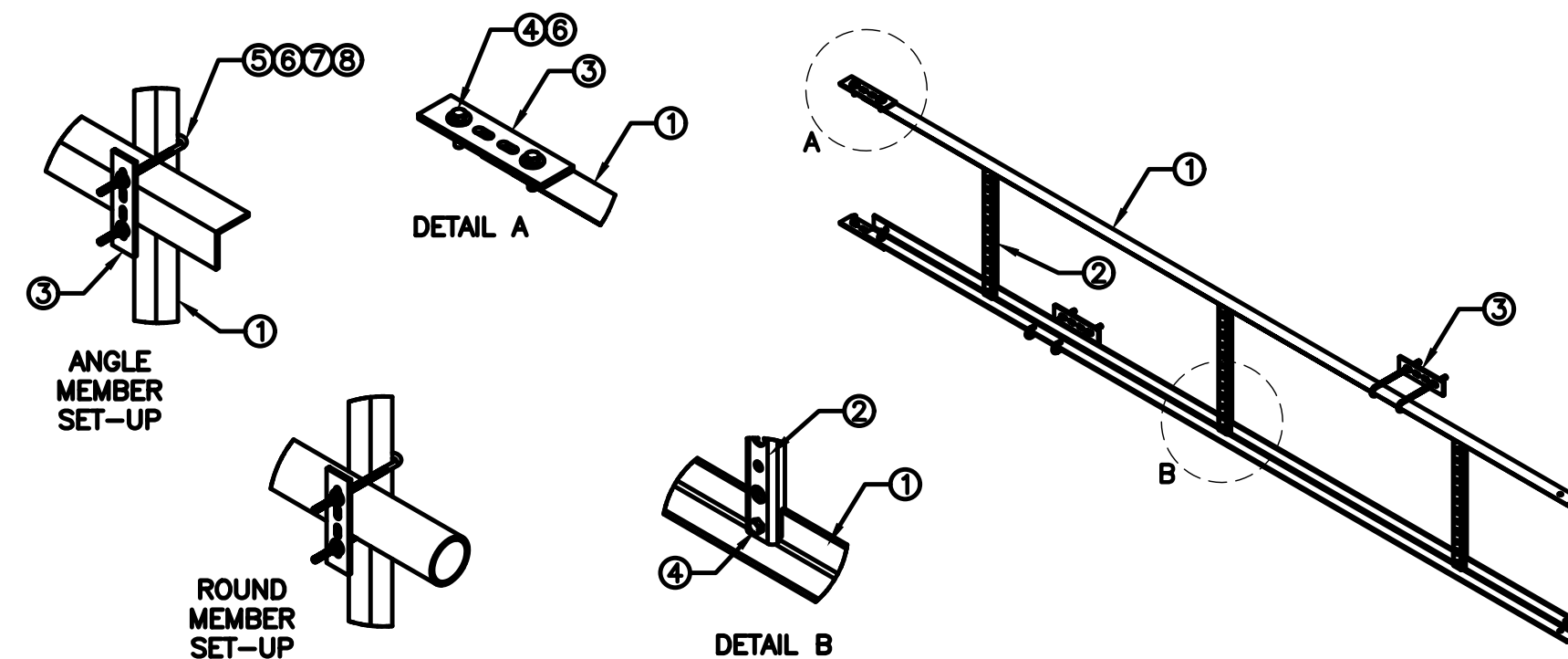

CABLE LADDER DETAIL

NO SCALE

8

COMMSCOPE V-FRAME MTC3975083	
FACE SIZE	8'-0"
WEIGHT	352.136 lbs

NOTE:
OR DISH Wireless L.L.C.
APPROVED EQUIVALENT

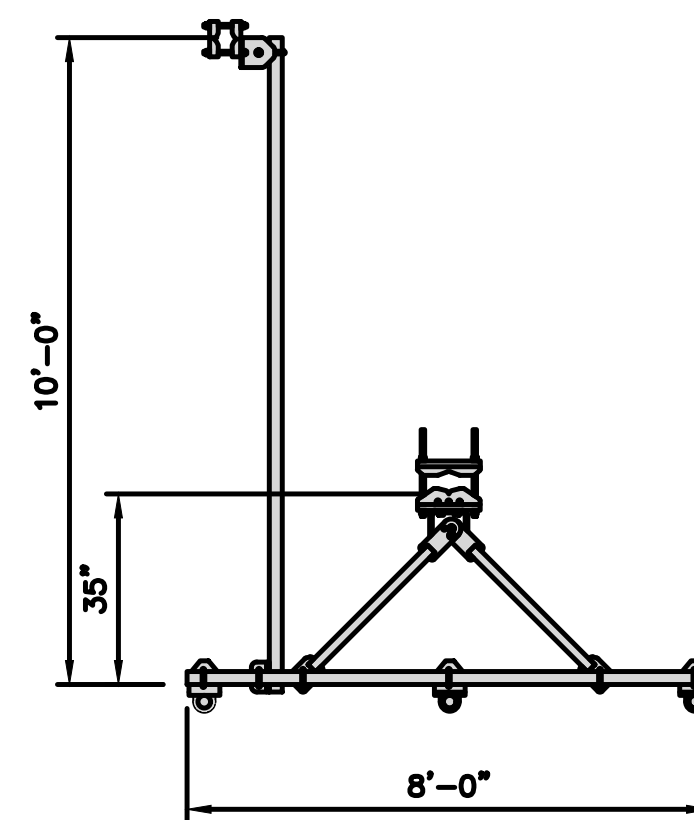

ANTENNA FRAME DETAIL

NO SCALE

9

JMA ANTENNA MOUNT BRACKET #91900318	
TOTAL WEIGHT (WITH BRACKETS)	18 lbs (8.18 Kg)
POLE DIAMETER RANGE	2.5" TO 4.5"

NOTE:
KIT #91900318: TOP AND BOTTOM BRACKETS
FOR 4-, 6-, AND 8-FOOT ANTENNAS
ANTENNA BRACKET NOT PART OF KIT

NOTE:
OR DISH Wireless L.L.C.
APPROVED EQUIVALENT

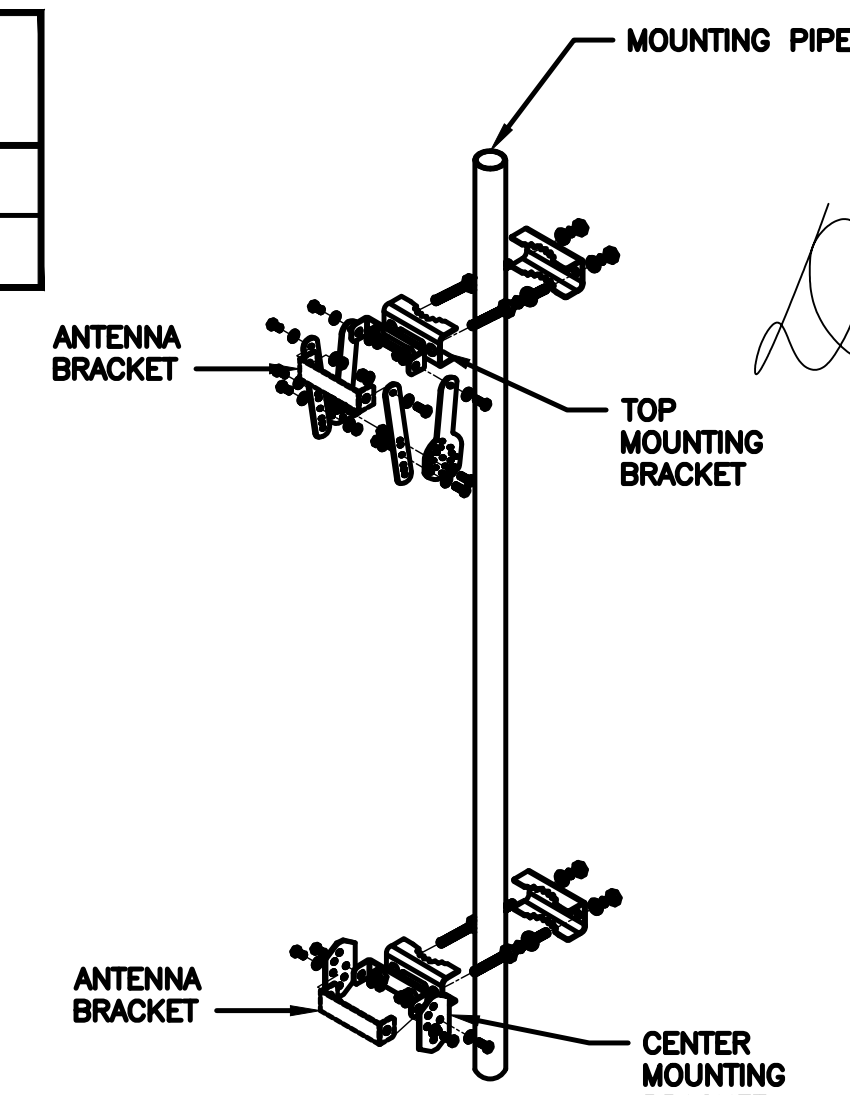

ANTENNA BRACKET DETAIL

NO SCALE

6

dish
wireless.

5701 SOUTH SANTA FE DRIVE
LITTLETON, CO 80120

HG
HUDSON
Design Group LLC

45 BEECHWOOD DRIVE TEL: (978) 557-5553
N. ANDOVER, MA 01845 FAX: (978) 336-5586

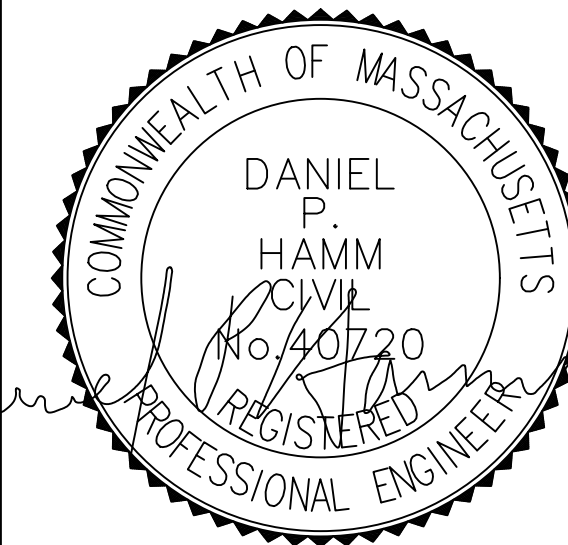

IT IS A VIOLATION OF LAW FOR ANY PERSON,
UNLESS THEY ARE ACTING UNDER THE DIRECTION
OF A LICENSED PROFESSIONAL ENGINEER,
TO ALTER THIS DOCUMENT.

DRAWN BY: CHECKED BY: APPROVED BY:

PS SMA DPH

RFDS REV #: 0

**PRELIMINARY
DOCUMENTS**

SUBMITTALS		
REV	DATE	DESCRIPTION
A	11/15/2021	ISSUED FOR REVIEW
B	01/21/2022	ISSUED FOR REVIEW

A&E PROJECT NUMBER
BOBOS00592A

DISH Wireless L.L.C.
PROJECT INFORMATION
BOBOS00592A
CROWN CASTLE BU#841273
344 ROUTE 6
NORTH TRURO, MA 02652

SHEET TITLE
EQUIPMENT DETAILS

SHEET NUMBER

A-6

NOTES

1. CONTRACTOR SHALL FIELD VERIFY ALL PROPOSED UNDERGROUND UTILITY CONDUIT ROUTE.
2. ANTENNAS AND MOUNTS OMITTED FOR CLARITY.
3. DUE TO UTILITY EASEMENT RIGHTS SPECIFIED IN THE GROUND LEASE, CUSTOMER MAY INSTALL EQUIPMENT WITHIN SPECIFIED UTILITY EASEMENT AREA. "PWR" AND "FBR" PATH DEPICTED ON A-1 AND E-1 REPRESENT PLANNED ROUTING BASED ON BEST AVAILABLE INFORMATION INCLUDING BUT NOT LIMITED TO A SURVEY, EXHIBITS, METES AND BOUNDS OF THE UTILITY EASEMENT, FIELD VERIFICATION, PRIOR PROJECT DOCUMENTATION AND OTHER REAL PROPERTY RIGHTS DOCUMENTS. WHEN INSTALLING THE UTILITIES PLEASE LOCATE AND FOLLOW EXISTING PATH, IF EXISTING PATH IS MATERIALLY INCONSISTENT WITH "PWR" AND "FBR" PATH DEPICTED ON A-1 AND E-1 AND SAID VARIANCE IS NOT NOTED ON CDs, PLEASE NOTIFY TOWER OWNER AS FURTHER COORDINATION MAY BE NEEDED.

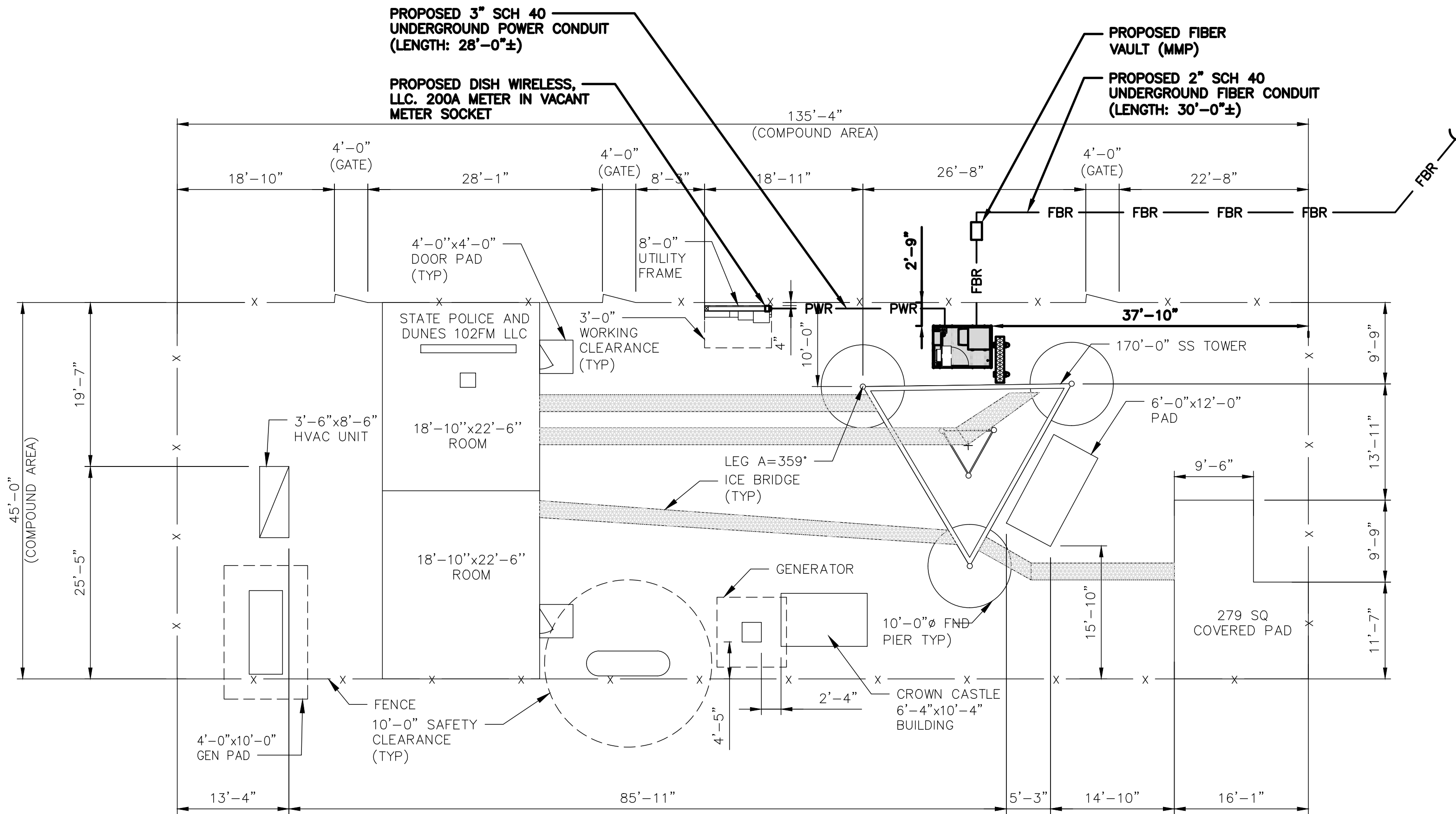

UTILITY ROUTE PLAN

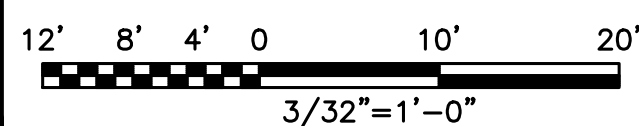

1

DC POWER WIRING SHALL BE COLOR CODED AT EACH END FOR IDENTIFYING +24V AND -48V CONDUCTORS. RED MARKINGS SHALL IDENTIFY +24V AND BLUE MARKINGS SHALL IDENTIFY -48V.

1. CONTRACTOR SHALL INSPECT THE EXISTING CONDITIONS PRIOR TO SUBMITTING A BID. ANY QUESTIONS ARISING DURING THE BID PERIOD IN REGARDS TO THE CONTRACTOR'S FUNCTIONS, THE SCOPE OF WORK, OR ANY OTHER ISSUE RELATED TO THIS PROJECT SHALL BE BROUGHT UP DURING THE BID PERIOD WITH THE PROJECT MANAGER FOR CLARIFICATION, NOT AFTER THE CONTRACT HAS BEEN AWARDED.
2. ALL ELECTRICAL WORK SHALL BE DONE IN ACCORDANCE WITH CURRENT NATIONAL ELECTRICAL CODES AND ALL STATE AND LOCAL CODES, LAWS, AND ORDINANCES. PROVIDE ALL COMPONENTS AND WIRING SIZES AS REQUIRED TO MEET NEC STANDARDS.
3. LOCATION OF EQUIPMENT, CONDUIT AND DEVICES SHOWN ON THE DRAWINGS ARE APPROXIMATE AND SHALL BE COORDINATED WITH FIELD CONDITIONS PRIOR TO CONSTRUCTION.
4. CONDUIT ROUGH-IN SHALL BE COORDINATED WITH THE MECHANICAL EQUIPMENT TO AVOID LOCATION CONFLICTS. VERIFY WITH THE MECHANICAL EQUIPMENT CONTRACTOR AND COMPLY AS REQUIRED.
5. CONTRACTOR SHALL PROVIDE ALL BREAKERS, CONDUITS AND CIRCUITS AS REQUIRED FOR A COMPLETE SYSTEM.
6. CONTRACTOR SHALL PROVIDE PULL BOXES AND JUNCTION BOXES AS REQUIRED BY THE NEC ARTICLE 314.
7. CONTRACTOR SHALL PROVIDE ALL STRAIN RELIEF AND CABLE SUPPORTS FOR ALL CABLE ASSEMBLIES. INSTALLATION SHALL BE IN ACCORDANCE WITH MANUFACTURER'S SPECIFICATIONS AND RECOMMENDATIONS.
8. ALL DISCONNECTS AND CONTROLLING DEVICES SHALL BE PROVIDED WITH ENGRAVED PHENOLIC NAMEPLATES INDICATING EQUIPMENT CONTROLLED, BRANCH CIRCUITS INSTALLED ON, AND PANEL FIELD LOCATIONS FED FROM.
9. INSTALL AN EQUIPMENT GROUNDING CONDUCTOR IN ALL CONDUITS PER THE SPECIFICATIONS AND NEC 250. THE EQUIPMENT GROUNDING CONDUCTORS SHALL BE BONDED AT ALL JUNCTION BOXES, PULL BOXES, AND ALL DISCONNECT SWITCHES, AND EQUIPMENT CABINETS.
10. ALL NEW MATERIAL SHALL HAVE A U.L. LABEL.
11. PANEL SCHEDULE LOADING AND CIRCUIT ARRANGEMENTS REFLECT POST-CONSTRUCTION EQUIPMENT.
12. CONTRACTOR SHALL BE RESPONSIBLE FOR AS-BUILT PANEL SCHEDULE AND SITE DRAWINGS.
13. ALL TRENCHES IN COMPOUND TO BE HAND DUG

ELECTRICAL NOTES

2

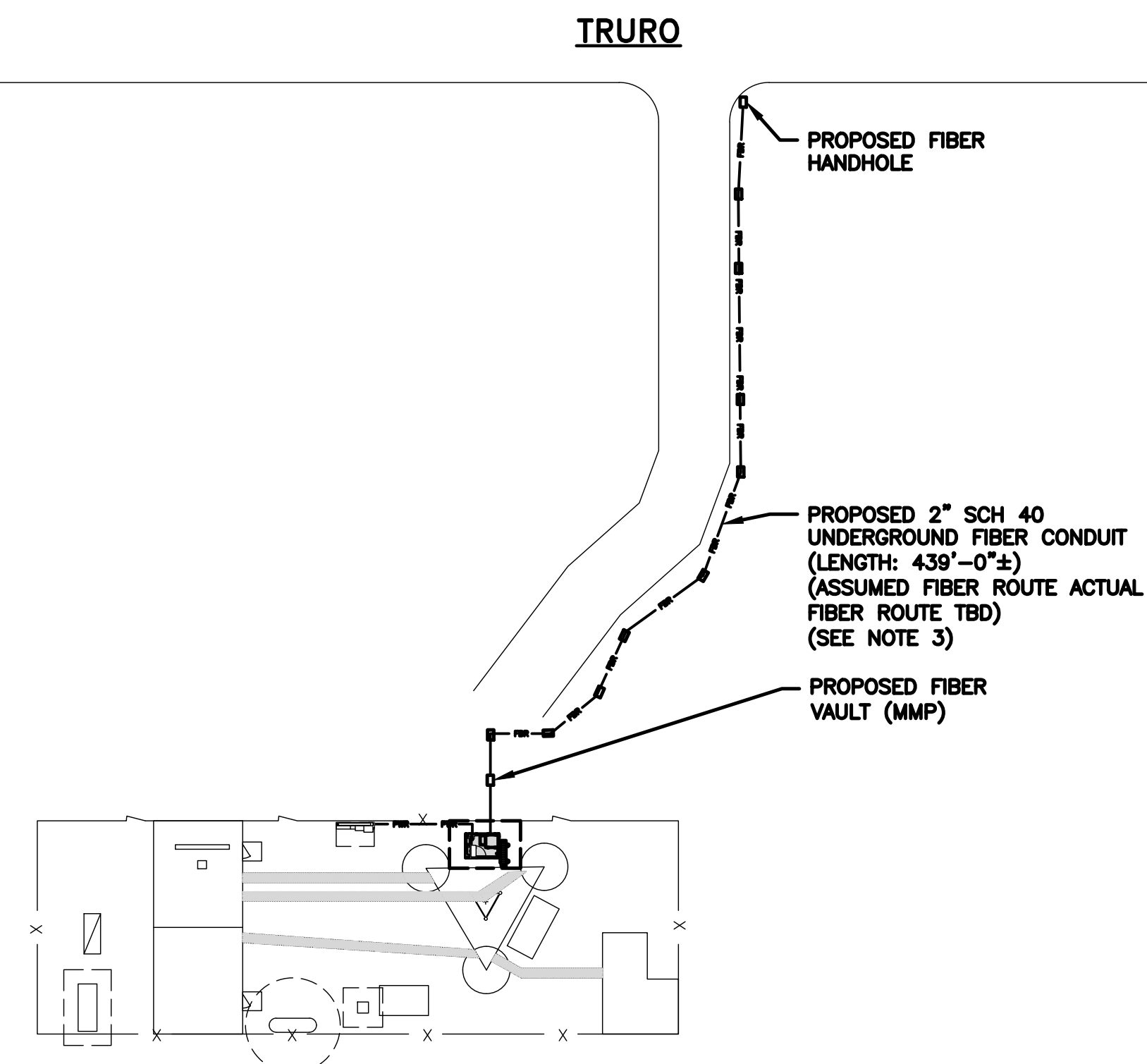

OVERALL UTILITY ROUTE PLAN

NO SCALE

3



5701 SOUTH SANTA FE DRIVE
LITTLETON, CO 80120



45 BEECHWOOD DRIVE TEL: (978) 557-5553
N. ANDOVER, MA 01845 FAX: (978) 336-5586

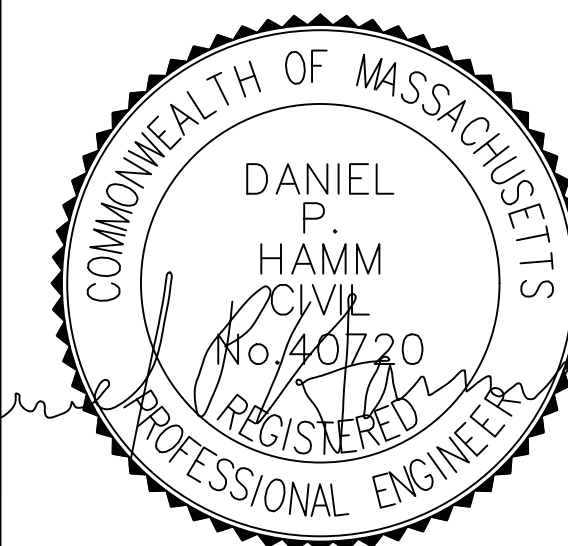

IT IS A VIOLATION OF LAW FOR ANY PERSON, UNLESS THEY ARE ACTING UNDER THE DIRECTION OF A LICENSED PROFESSIONAL ENGINEER, TO ALTER THIS DOCUMENT.

DRAWN BY: PS CHECKED BY: SMA APPROVED BY: DPH

RFDS REV #: 0

PRELIMINARY DOCUMENTS

SUBMITTALS		
REV	DATE	DESCRIPTION
A	11/15/2021	ISSUED FOR REVIEW
B	01/21/2022	ISSUED FOR REVIEW

A&E PROJECT NUMBER
BOBOS00592A

DISH Wireless L.L.C.
PROJECT INFORMATION
BOBOS00592A
CROWN CASTLE BU#841273
344 ROUTE 6
NORTH TRURO, MA 02652

SHEET TITLE
ELECTRICAL/FIBER ROUTE
PLAN AND NOTES

SHEET NUMBER
E-1

CARLON EXPANSION FITTINGS				
COUPLING END PART#	MALE TERMINAL ADAPTER END PART#	SIZE	STD CTN QTY.	TRAVEL LENGTH
E945D	E945DX	1/2"	20	4"
E945E	E945EX	3/4"	15	4"
E945F	E945FX	1"	10	4"
E945G	E945GX	1 1/4"	5	4"
E945H	E945HX	1 1/2"	5	4"
E945J	E945JX	2"	15	8"
E945K	E945KX	2 1/2"	10	8"
E945L	E945LX	3"	10	8"
E945M	E945MX	3 1/2"	5	8"
E945N	E945NX	4"	5	8"
E945P	E945PX	5"	1	8"
E945R	E945RX	6"	1	8"

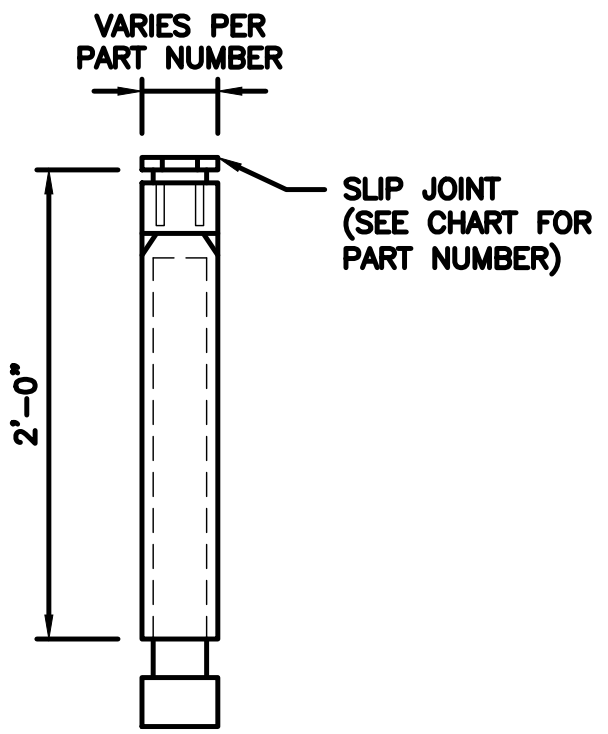

NOTE: CONTRACTOR TO INSTALL EXPANSION FITTING SLIP JOINT AT METER CENTER CONDUIT TERMINATION, AS PER LOCAL UTILITY POLICY, ORDINANCE AND/OR SPECIFIED REQUIREMENT.

TRENCHING NOTES

- CONTRACTOR SHALL RESTORE THE TRENCH TO ITS ORIGINAL CONDITIONS BY EITHER SEEDING OR SODDING GRASS AREAS, OR REPLACING ASPHALT OR CONCRETE AREAS TO ITS ORIGINAL CROSS SECTION.
- TRENCHING SAFETY; INCLUDING, BUT NOT LIMITED TO SOIL CLASSIFICATION, SLOPING, AND SHORING, SHALL BE GOVERNED BY THE CURRENT OSHA TRENCHING AND EXCAVATION SAFETY STANDARDS.
- ALL CONDUITS SHALL BE INSTALLED IN COMPLIANCE WITH THE CURRENT NATIONAL ELECTRIC CODE (NEC) OR AS REQUIRED BY THE LOCAL JURISDICTION, WHICHEVER IS THE MOST STRINGENT.

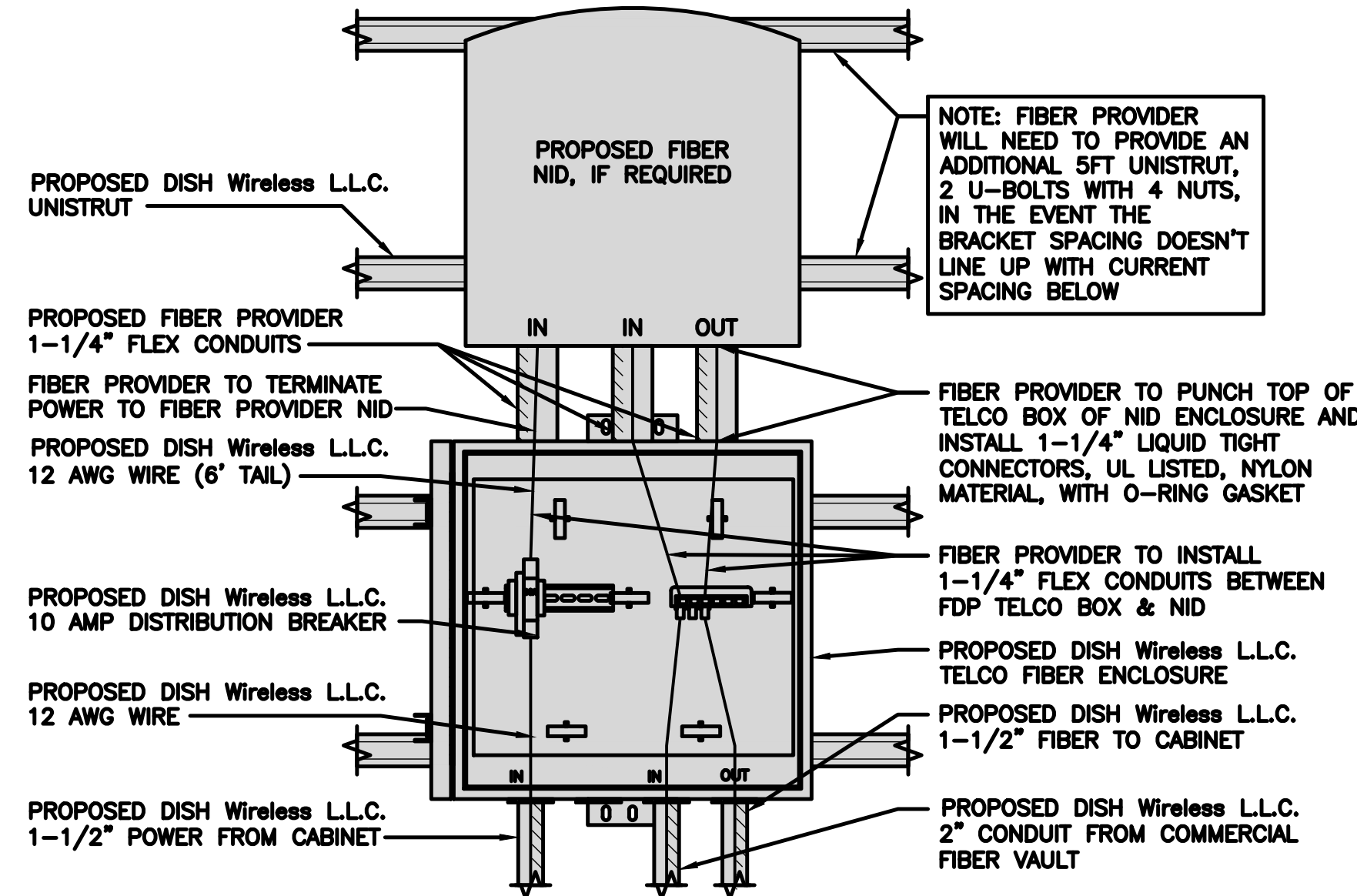
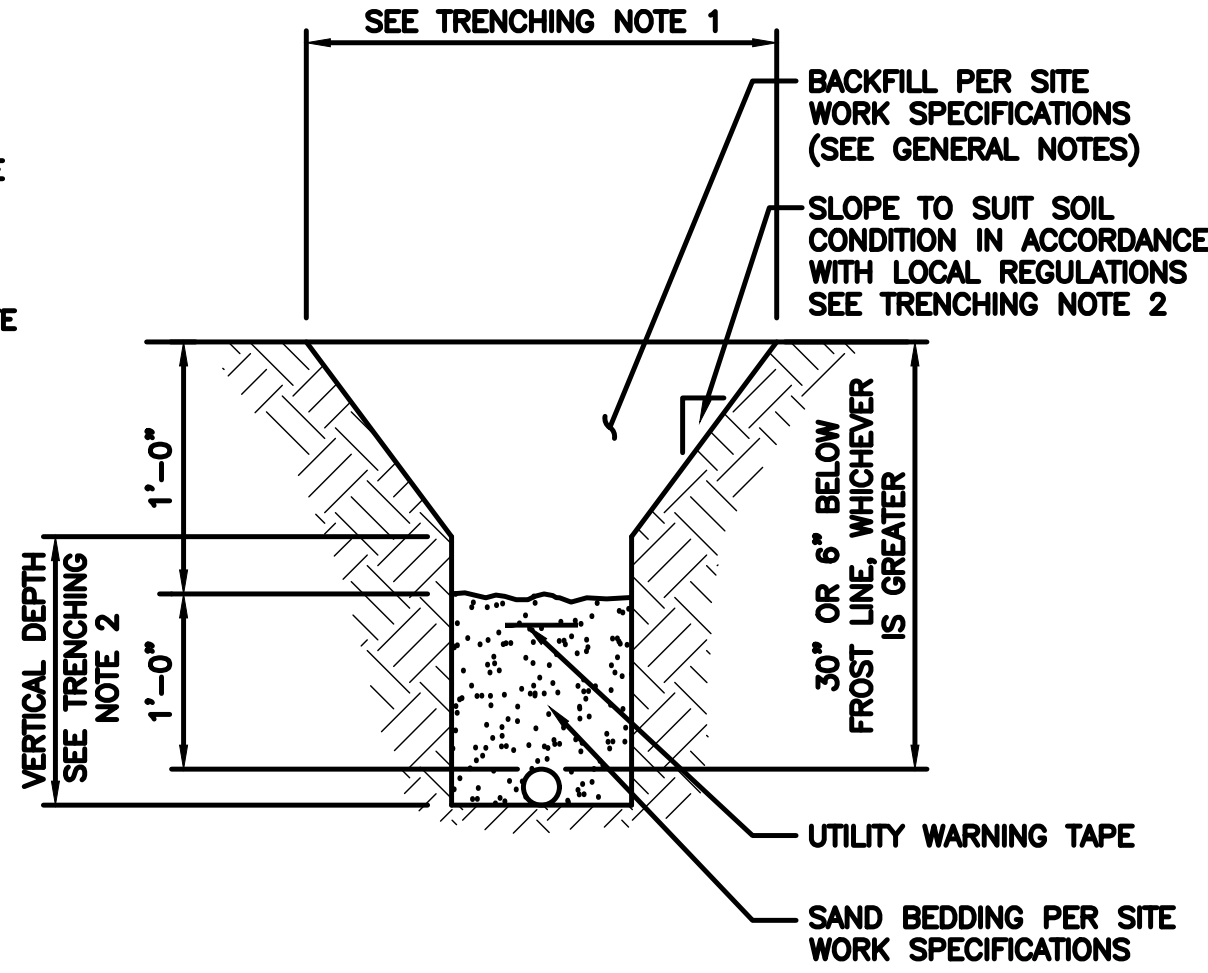

NOTE: FIBER PROVIDER WILL NEED TO PROVIDE AN ADDITIONAL 5FT UNISTRUT, IN THE EVENT THE BRACKET SPACING DOESN'T LINE UP WITH CURRENT SPACING BELOW



5701 SOUTH SANTA FE DRIVE
LITTLETON, CO 80120



45 BEECHWOOD DRIVE N. ANDOVER, MA 01845 TEL: (978) 557-5553 FAX: (978) 336-5586

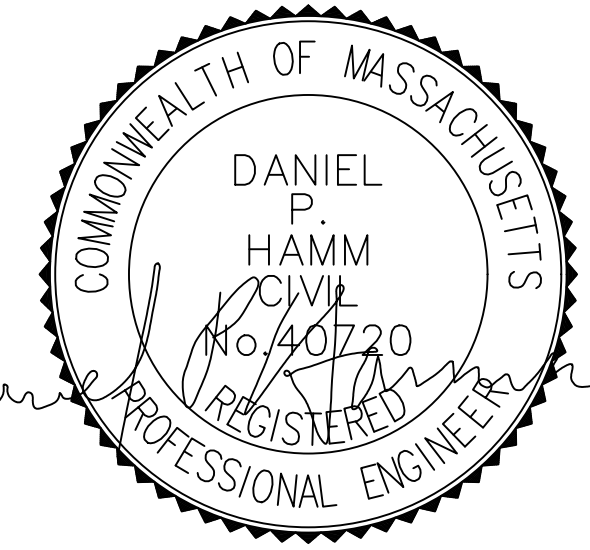

IT IS A VIOLATION OF LAW FOR ANY PERSON, UNLESS THEY ARE ACTING UNDER THE DIRECTION OF A LICENSED PROFESSIONAL ENGINEER, TO ALTER THIS DOCUMENT.

DRAWN BY: PS CHECKED BY: SMA APPROVED BY: DPH

RFDS REV #: 0

PRELIMINARY DOCUMENTS

SUBMITTALS		
REV	DATE	DESCRIPTION
A	11/15/2021	ISSUED FOR REVIEW
B	01/21/2022	ISSUED FOR REVIEW

A&E PROJECT NUMBER
BOBOS00592A

DISH Wireless L.L.C.
PROJECT INFORMATION
BOBOS00592A
CROWN CASTLE BU#841273
344 ROUTE 6
NORTH TRURO, MA 02652

SHEET TITLE
ELECTRICAL
DETAILS

SHEET NUMBER
E-2

EXPANSION JOINT DETAIL NO SCALE 1

TYPICAL UNDERGROUND TRENCH DETAIL NO SCALE 2

LIT TELCO BOX - INTERIOR WIRING LAYOUT (OPTIONAL) NO SCALE 3

NOT USED NO SCALE 4

NOT USED NO SCALE 5

NOT USED NO SCALE 6

NOT USED NO SCALE 7

NOT USED NO SCALE 8

NOT USED NO SCALE 9

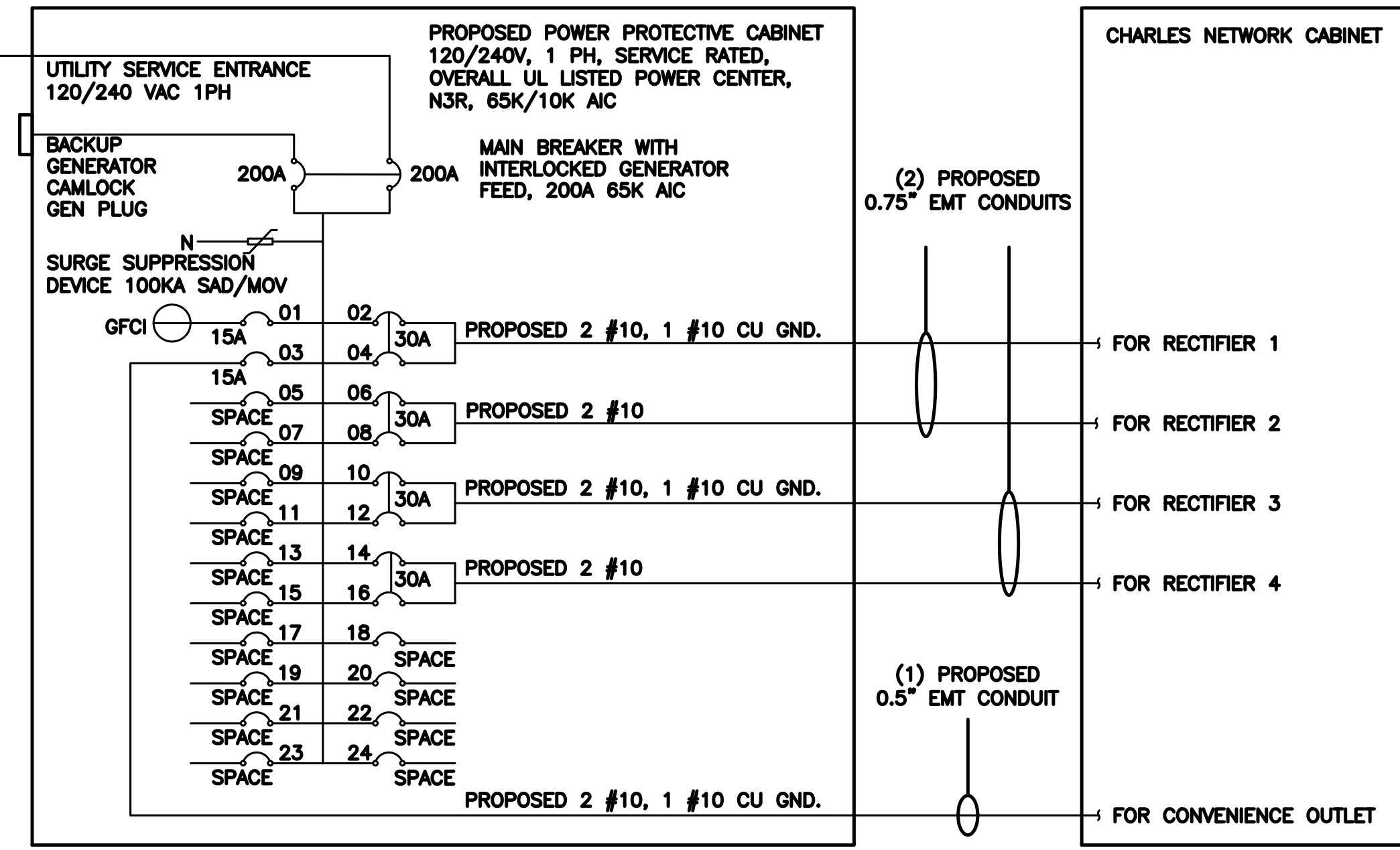
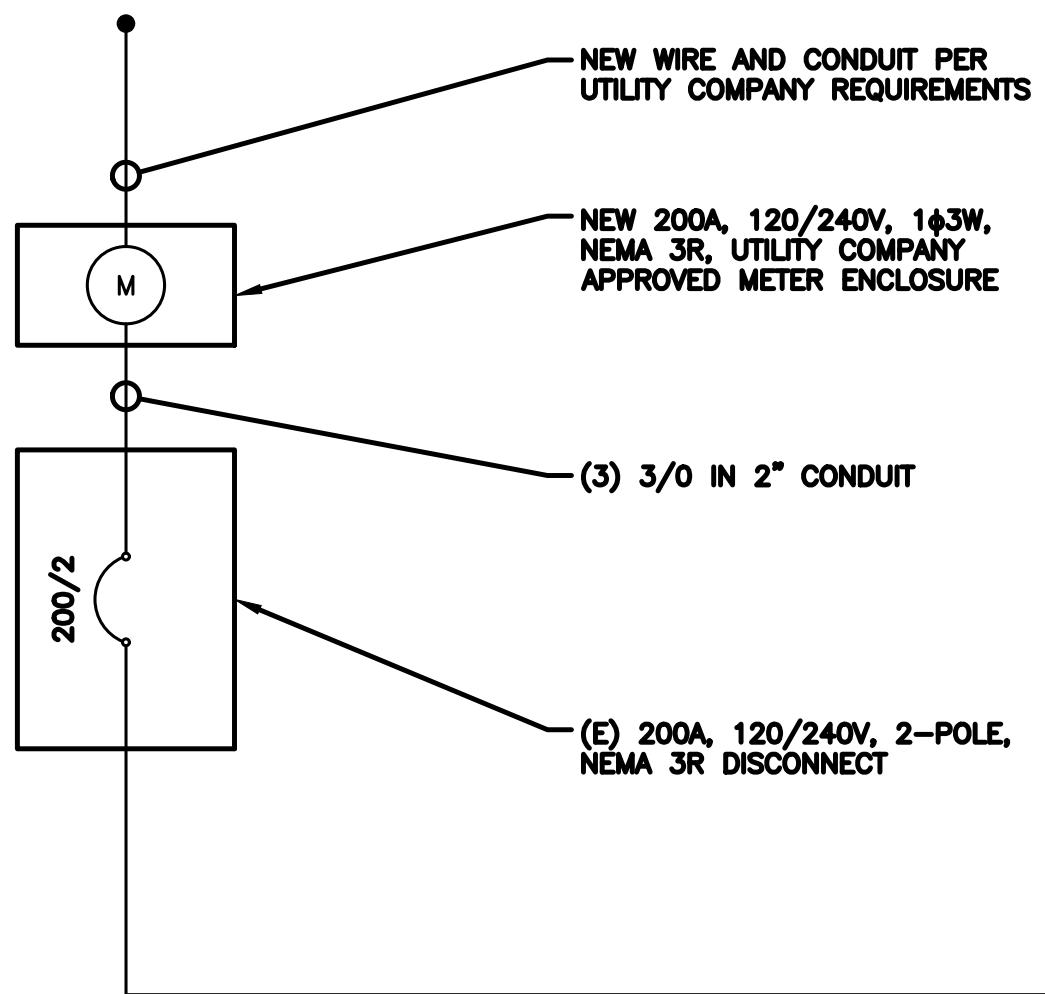

NOTE: BRANCH CIRCUIT WIRING SUPPLYING RECTIFIERS ARE TO BE RATED UL1015, 105°C, 600V, AND PVC INSULATED, IN THE SIZES SHOWN IN THE ONE-LINE DIAGRAM. CONTRACTOR MAY SUBSTITUTE UL1015 WIRE FOR THWN-2 FOR CONVENIENCE OUTLET BRANCH CIRCUIT.

BREAKERS REQUIRED:
 (4) 30A, 2P BREAKER - SQUARE D P/N:Q0230
 (1) 15A, 1P BREAKER - SQUARE D P/N:Q0115

NOTES

THE ENGINEER OF RECORD HAS PERFORMED ALL REQUIRED SHORT CIRCUIT CALCULATIONS AND THE AIC RATINGS FOR EACH DEVICE IS ADEQUATE TO PROTECT THE EQUIPMENT AND THE ELECTRICAL SYSTEM.

THE ENGINEER OF RECORD HAS PERFORMED ALL REQUIRED VOLTAGE DROP CALCULATIONS AND ALL BRANCH CIRCUIT AND FEEDERS COMPLY WITH THE NEC (LISTED ON T-1) ARTICLE 210.19(A)(1) FPN NO. 4.

THE (2) CONDUITS WITH (4) CURRENT CARRYING CONDUCTORS EACH, SHALL APPLY THE ADJUSTMENT FACTOR OF 80% PER 2014/17 NEC TABLE 310.15(B)(3)(a) OR 2020 NEC TABLE 310.15(C)(1) FOR UL1015 WIRE.

#12 FOR 15A-20A/1P BREAKER: 0.8 x 30A = 24.0A
 #10 FOR 25A-30A/2P BREAKER: 0.8 x 40A = 32.0A
 #8 FOR 35A-40A/2P BREAKER: 0.8 x 55A = 44.0A
 #6 FOR 45A-60A/2P BREAKER: 0.8 x 75A = 60.0A

CONDUIT SIZING: AT 40% FILL PER NEC CHAPTER 9, TABLE 4, ARTICLE 358.
 0.5" CONDUIT - 0.122 SQ. IN AREA
 0.75" CONDUIT - 0.213 SQ. IN AREA
 2.0" CONDUIT - 1.316 SQ. IN AREA
 3.0" CONDUIT - 2.907 SQ. IN AREA

CABINET CONVENIENCE OUTLET CONDUCTORS (1 CONDUIT): USING THWN-2, CU.
 #10 - 0.0211 SQ. IN X 2 = 0.0422 SQ. IN
 #10 - 0.0211 SQ. IN X 1 = 0.0211 SQ. IN <GROUND
TOTAL = 0.0633 SQ. IN

0.5" EMT CONDUIT IS ADEQUATE TO HANDLE THE TOTAL OF (3) WIRES, INCLUDING GROUND WIRE, AS INDICATED ABOVE.

RECTIFIER CONDUCTORS (2 CONDUITS): USING UL1015, CU.
 #10 - 0.0266 SQ. IN X 4 = 0.1064 SQ. IN
 #10 - 0.0082 SQ. IN X 1 = 0.0082 SQ. IN <BARE GROUND
TOTAL = 0.1146 SQ. IN

0.75" EMT CONDUIT IS ADEQUATE TO HANDLE THE TOTAL OF (5) WIRES, INCLUDING GROUND WIRE, AS INDICATED ABOVE.

PPC FEED CONDUCTORS (1 CONDUIT): USING THWN, CU.
 3/0 - 0.2679 SQ. IN X 3 = 0.8037 SQ. IN
 #6 - 0.0507 SQ. IN X 1 = 0.0507 SQ. IN <GROUND
TOTAL = 0.8544 SQ. IN

3.0" SCH 40 PVC CONDUIT IS ADEQUATE TO HANDLE THE TOTAL OF (4) WIRES, INCLUDING GROUND WIRE, AS INDICATED ABOVE.



5701 SOUTH SANTA FE DRIVE
LITTLETON, CO 80120



45 BEECHWOOD DRIVE N. ANDOVER, MA 01845 TEL: (978) 557-5553 FAX: (978) 336-5586

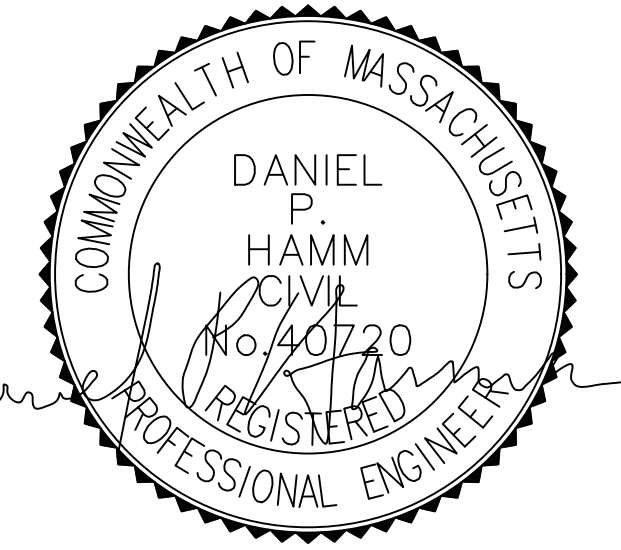

IT IS A VIOLATION OF LAW FOR ANY PERSON, UNLESS THEY ARE ACTING UNDER THE DIRECTION OF A LICENSED PROFESSIONAL ENGINEER, TO ALTER THIS DOCUMENT.

DRAWN BY: PS CHECKED BY: SMA APPROVED BY: DPH

RFDS REV #: 0

PRELIMINARY DOCUMENTS

SUBMITTALS		
REV	DATE	DESCRIPTION
A	11/15/2021	ISSUED FOR REVIEW
B	01/21/2022	ISSUED FOR REVIEW

A&E PROJECT NUMBER
BOBOS00592A

DISH Wireless L.L.C.
PROJECT INFORMATION
BOBOS00592A
CROWN CASTLE BU#841273
344 ROUTE 6
NORTH TRURO, MA 02652

SHEET TITLE
ELECTRICAL ONE-LINE, FAULT CALCS & PANEL SCHEDULE

SHEET NUMBER
E-3

PPC ONE-LINE DIAGRAM

NO SCALE 11

PROPOSED CHARLES PANEL SCHEDULE										
LOAD SERVED	VOLT AMPS (WATTS)		TRIP	CKT #	PHASE	CKT #	TRIP	VOLT AMPS (WATTS)		LOAD SERVED
	L1	L2						L1	L2	
PPC GFCI OUTLET	180	180	15A	1	A	2	30A	2880	2880	ABB/GE INFINITY RECTIFIER 1
CHARLES GFCI OUTLET			15A	3	B	4				
-SPACE-				5	A	6	30A	2880	2880	ABB/GE INFINITY RECTIFIER 2
-SPACE-				7	B	8				
-SPACE-				9	A	10	30A	2880	2880	ABB/GE INFINITY RECTIFIER 3
-SPACE-				11	B	12				
-SPACE-				13	A	14	30A	2880	2880	ABB/GE INFINITY RECTIFIER 4
-SPACE-				15	B	16				
-SPACE-				17	A	18				-SPACE-
-SPACE-				19	B	20				-SPACE-
-SPACE-				21	A	22				-SPACE-
-SPACE-				23	B	24				-SPACE-
VOLTAGE AMPS		180	180					11520	11520	
200A MCB, 1ϕ, 24 SPACE, 120/240V				L1	L2					
MB RATING: 65,000 AIC				11700	11700					
				98	98					
				98						
				123						

PANEL SCHEDULE

NO SCALE 2

NOT USED

NO SCALE 3

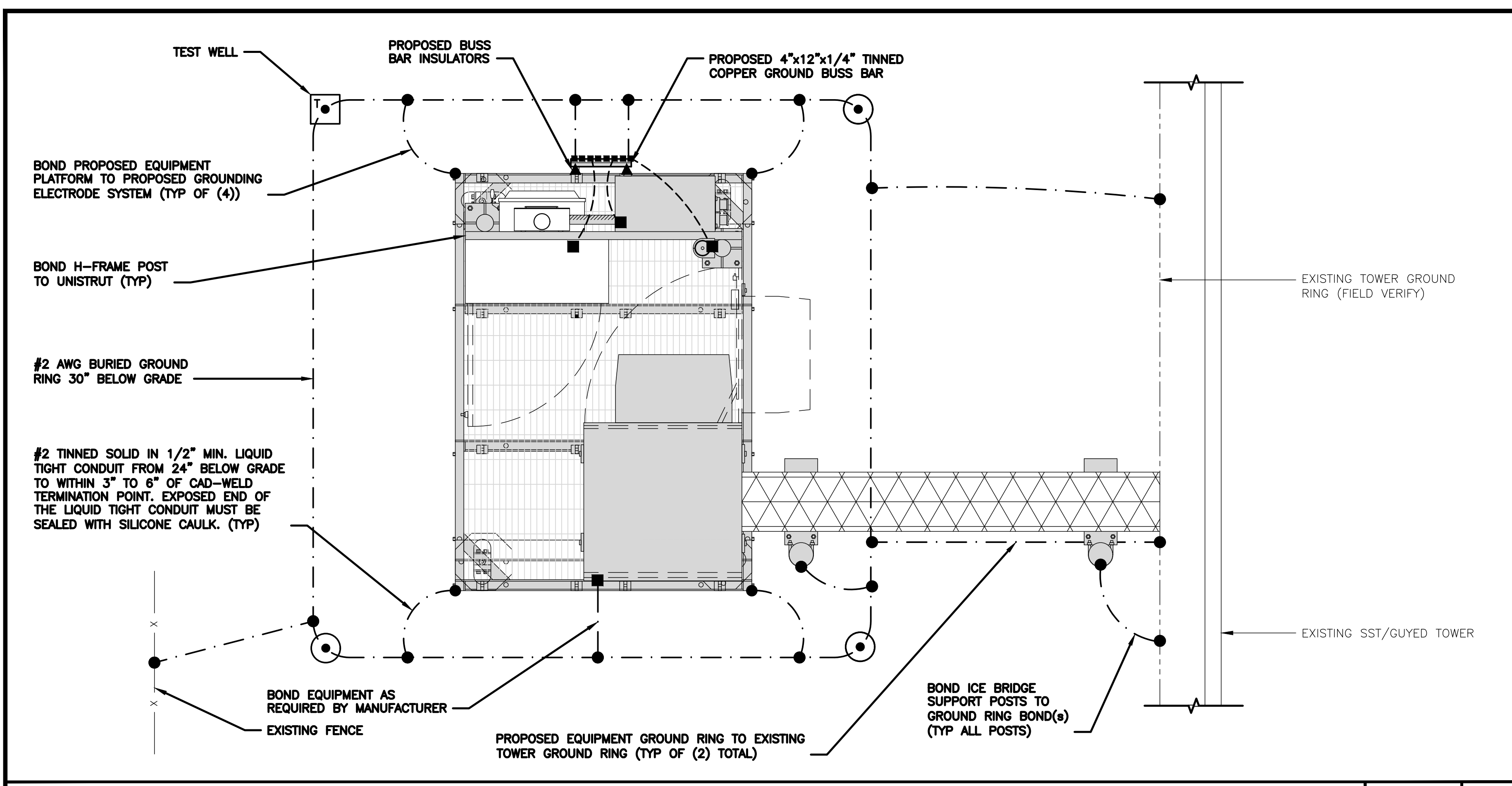

TYPICAL EQUIPMENT GROUNDING PLAN

NO SCALE 1

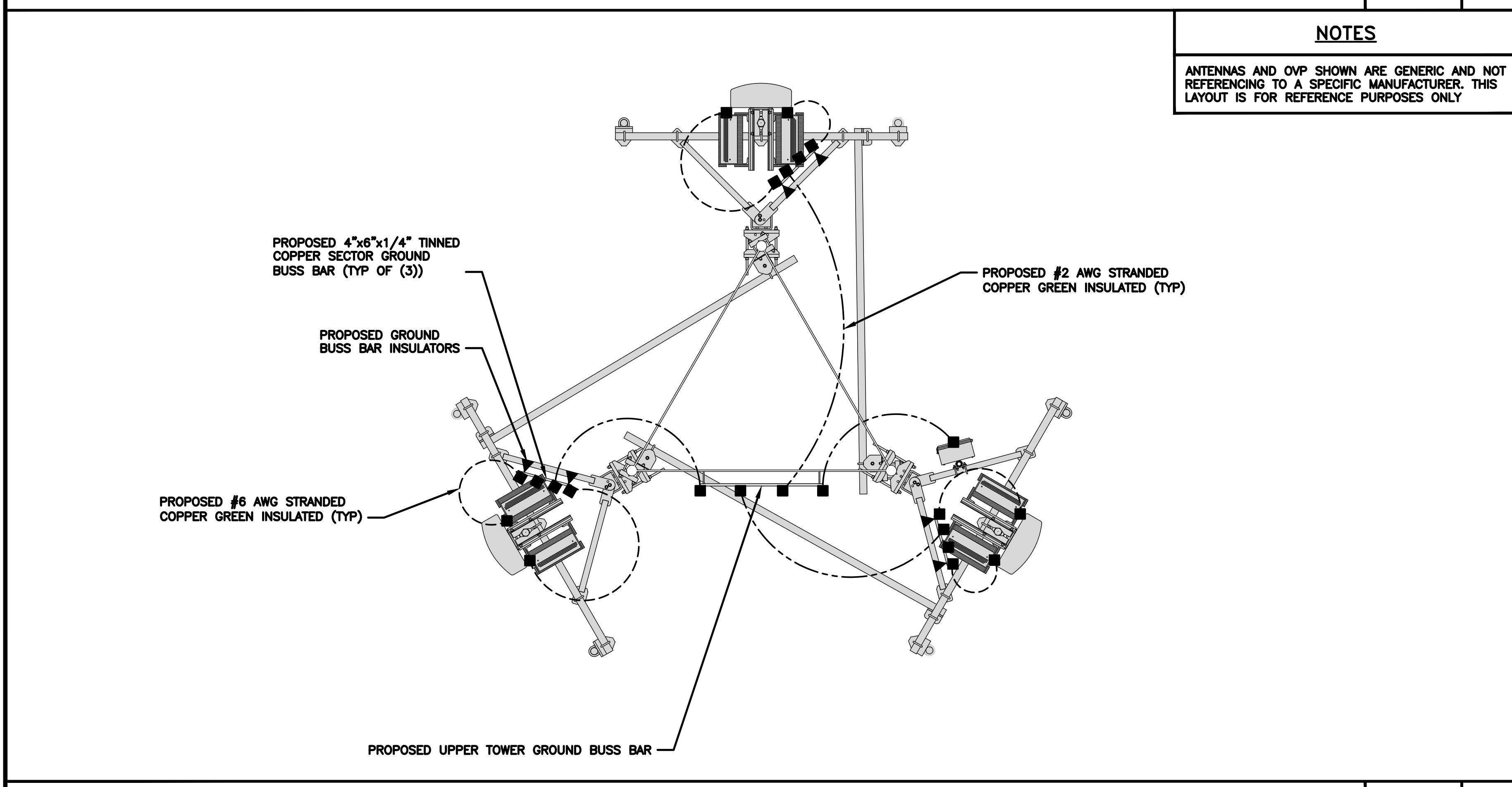

TYPICAL ANTENNA GROUNDING PLAN

NO SCALE 2

- EXOTHERMIC CONNECTION
- MECHANICAL CONNECTION
- ▬ GROUND BUS BAR
- GROUND ROD
- TEST GROUND ROD WITH INSPECTION SLEEVE
- #6 AWG STRANDED & INSULATED
- - - - #2 AWG SOLID COPPER TINNED
- #2 AWG STRANDED & INSULATED
- ▲ BUSS BAR INSULATOR

GROUNDING LEGEND

1. GROUNDING IS SHOWN DIAGRAMMATICALLY ONLY.
2. CONTRACTOR SHALL GROUND ALL EQUIPMENT AS A COMPLETE SYSTEM. GROUNDING SHALL BE IN COMPLIANCE WITH NEC SECTION 250 AND DISH Wireless L.L.C. GROUNDING AND BONDING REQUIREMENTS AND MANUFACTURER'S SPECIFICATIONS.
3. ALL GROUND CONDUCTORS SHALL BE COPPER; NO ALUMINUM CONDUCTORS SHALL BE USED.

GROUNDING KEY NOTES

- (A) EXTERIOR GROUND RING: #2 AWG SOLID COPPER, BURIED AT A DEPTH OF AT LEAST 30 INCHES BELOW GRADE, OR 6 INCHES BELOW THE FROST LINE AND APPROXIMATELY 24 INCHES FROM THE EXTERIOR WALL OR FOOTING.
- (B) TOWER GROUND RING: THE GROUND RING SYSTEM SHALL BE INSTALLED AROUND AN ANTENNA TOWER'S LEGS, AND/OR GUY ANCHORS. WHERE SEPARATE SYSTEMS HAVE BEEN PROVIDED FOR THE TOWER AND THE BUILDING, AT LEAST TWO BONDS SHALL BE MADE BETWEEN THE TOWER RING GROUND SYSTEM AND THE BUILDING RING GROUND SYSTEM USING MINIMUM #2 AWG SOLID COPPER CONDUCTORS.
- (C) INTERIOR GROUND RING: #2 AWG STRANDED GREEN INSULATED COPPER CONDUCTOR EXTENDED AROUND THE PERIMETER OF THE EQUIPMENT AREA. ALL NON-TELECOMMUNICATIONS RELATED METALLIC OBJECTS FOUND WITHIN A SITE SHALL BE GROUNDED TO THE INTERIOR GROUND RING WITH #6 AWG STRANDED GREEN INSULATED CONDUCTOR.
- (D) BOND TO INTERIOR GROUND RING: #2 AWG SOLID TINNED COPPER WIRE PRIMARY BONDS SHALL BE PROVIDED AT LEAST AT FOUR POINTS ON THE INTERIOR GROUND RING, LOCATED AT THE CORNERS OF THE BUILDING.
- (E) GROUND ROD: UL LISTED COPPER CLAD STEEL. MINIMUM 1/2" DIAMETER BY EIGHT FEET LONG. GROUND RODS SHALL BE INSTALLED WITH INSPECTION SLEEVES. GROUND RODS SHALL BE DRIVEN TO THE DEPTH OF GROUND RING CONDUCTOR.
- (F) CELL REFERENCE GROUND BAR: POINT OF GROUND REFERENCE FOR ALL COMMUNICATIONS EQUIPMENT FRAMES. ALL BONDS ARE MADE WITH #2 AWG UNLESS NOTED OTHERWISE STRANDED GREEN INSULATED COPPER CONDUCTORS. BOND TO GROUND RING WITH (2) #2 SOLID TINNED COPPER CONDUCTORS.
- (G) HATCH PLATE GROUND BAR: BOND TO THE INTERIOR GROUND RING WITH TWO #2 AWG STRANDED GREEN INSULATED COPPER CONDUCTORS. WHEN A HATCH-PLATE AND A CELL REFERENCE GROUND BAR ARE BOTH PRESENT, THE CRGB MUST BE CONNECTED TO THE HATCH-PLATE AND TO THE INTERIOR GROUND RING USING (2) TWO #2 AWG STRANDED GREEN INSULATED COPPER CONDUCTORS EACH.
- (H) EXTERIOR CABLE ENTRY PORT GROUND BARS: LOCATED AT THE ENTRANCE TO THE CELL SITE BUILDING. BOND TO GROUND RING WITH A #2 AWG SOLID TINNED COPPER CONDUCTORS WITH AN EXOTHERMIC WELD AND INSPECTION SLEEVE.
- (I) TELCO GROUND BAR: BOND TO BOTH CELL REFERENCE GROUND BAR OR EXTERIOR GROUND RING.
- (J) FRAME BONDING: THE BONDING POINT FOR TELECOM EQUIPMENT FRAMES SHALL BE THE GROUND BUS THAT IS NOT ISOLATED FROM THE EQUIPMENTS METAL FRAMEWORK.
- (K) INTERIOR UNIT BONDS: METAL FRAMES, CABINETS AND INDIVIDUAL METALLIC UNITS LOCATED WITH THE AREA OF THE INTERIOR GROUND RING REQUIRE A #6 AWG STRANDED GREEN INSULATED COPPER BOND TO THE INTERIOR GROUND RING.
- (L) FENCE AND GATE GROUNDING: METAL FENCES WITHIN 7 FEET OF THE EXTERIOR GROUND RING OR OBJECTS BONDED TO THE EXTERIOR GROUND RING SHALL BE BONDED TO THE GROUND RING WITH A #2 AWG SOLID TINNED COPPER CONDUCTOR AT AN INTERVAL NOT EXCEEDING 25 FEET. BONDS SHALL BE MADE AT EACH GATE POST AND ACROSS GATE OPENINGS.
- (M) EXTERIOR UNIT BONDS: METALLIC OBJECTS, EXTERNAL TO OR MOUNTED TO THE BUILDING, SHALL BE BONDED TO THE EXTERIOR GROUND RING. USING #2 TINNED SOLID COPPER WIRE
- (N) ICE BRIDGE SUPPORTS: EACH ICE BRIDGE LEG SHALL BE BONDED TO THE GROUND RING WITH #2 AWG BARE TINNED COPPER CONDUCTOR. PROVIDE EXOTHERMIC WELDS AT BOTH THE ICE BRIDGE LEG AND BURIED GROUND RING.
- (O) DURING ALL DC POWER SYSTEM CHANGES INCLUDING DC SYSTEM CHANGE OUTS, RECTIFIER REPLACEMENTS OR ADDITIONS, BREAKER DISTRIBUTION CHANGES, BATTERY ADDITIONS, BATTERY REPLACEMENTS AND INSTALLATIONS OR CHANGES TO DC CONVERTER SYSTEMS IT SHALL BE REQUIRED THAT SERVICE CONTRACTORS VERIFY ALL DC POWER SYSTEMS ARE EQUIPPED WITH A MASTER DC SYSTEM RETURN GROUND CONDUCTOR FROM THE DC POWER SYSTEM COMMON RETURN BUS DIRECTLY CONNECTED TO THE CELL SITE REFERENCE GROUND BAR
- (P) TOWER TOP COLLECTOR BUSS BAR IS TO BE MECHANICALLY BONDED TO TOWER STEEL.
REFER TO DISH Wireless L.L.C. GROUNDING NOTES.

GROUNDING KEY NOTES

NO SCALE 3



5701 SOUTH SANTA FE DRIVE
LITTLETON, CO 80120



45 BEECHWOOD DRIVE N. ANDOVER, MA 01845 TEL: (978) 557-5553 FAX: (978) 336-5586

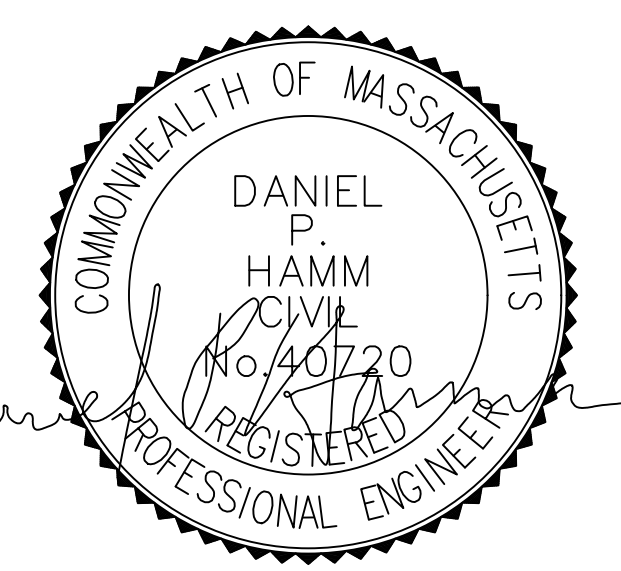

IT IS A VIOLATION OF LAW FOR ANY PERSON, UNLESS THEY ARE ACTING UNDER THE DIRECTION OF A LICENSED PROFESSIONAL ENGINEER, TO ALTER THIS DOCUMENT.

DRAWN BY: PS CHECKED BY: SMA APPROVED BY: DPH

RFDS REV #: 0

PRELIMINARY DOCUMENTS

SUBMITTALS		
REV	DATE	DESCRIPTION
A	11/15/2021	ISSUED FOR REVIEW
B	01/21/2022	ISSUED FOR REVIEW

A&E PROJECT NUMBER
BOBOS00592A

DISH Wireless L.L.C.
PROJECT INFORMATION
BOBOS00592A
CROWN CASTLE BU#841273
344 ROUTE 6
NORTH TRURO, MA 02652

SHEET TITLE
GROUNDING PLANS AND NOTES

SHEET NUMBER
G-1

NOTES
EQUIPMENT CABINET OMITTED FOR CLARITY

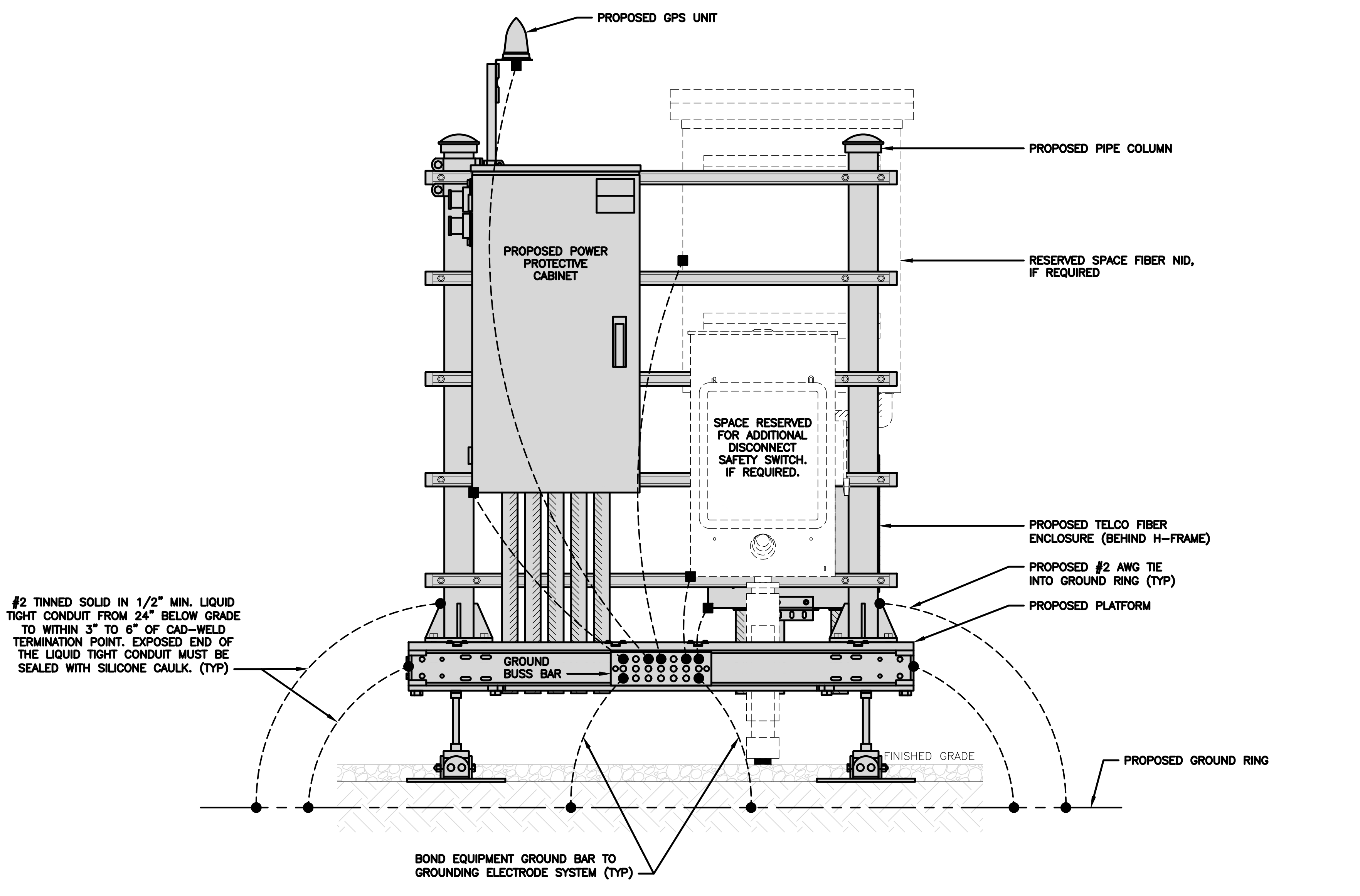

H-FRAME GROUNDING DETAIL NO SCALE 1

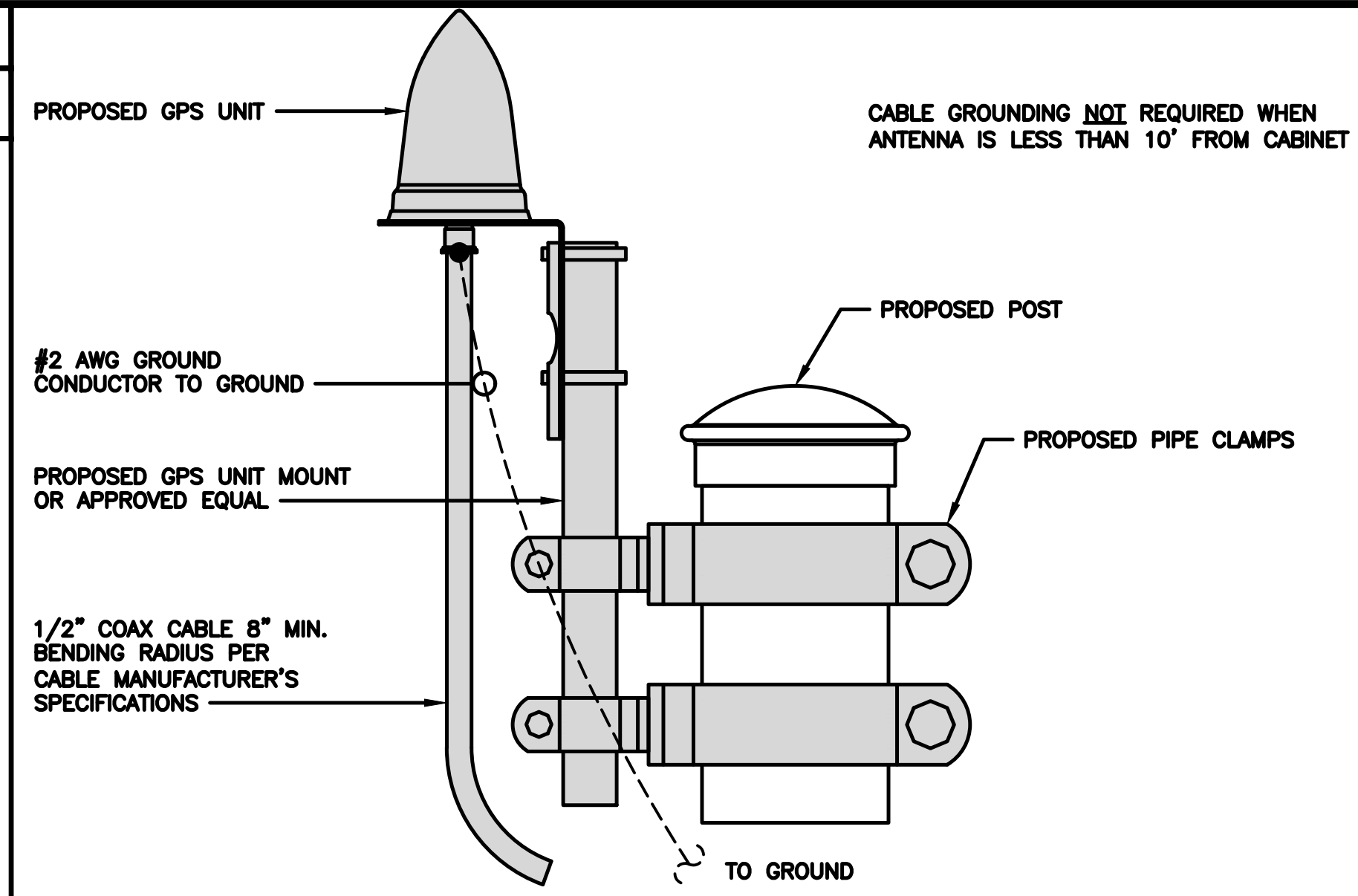

TYPICAL GPS UNIT GROUNDING NO SCALE 2

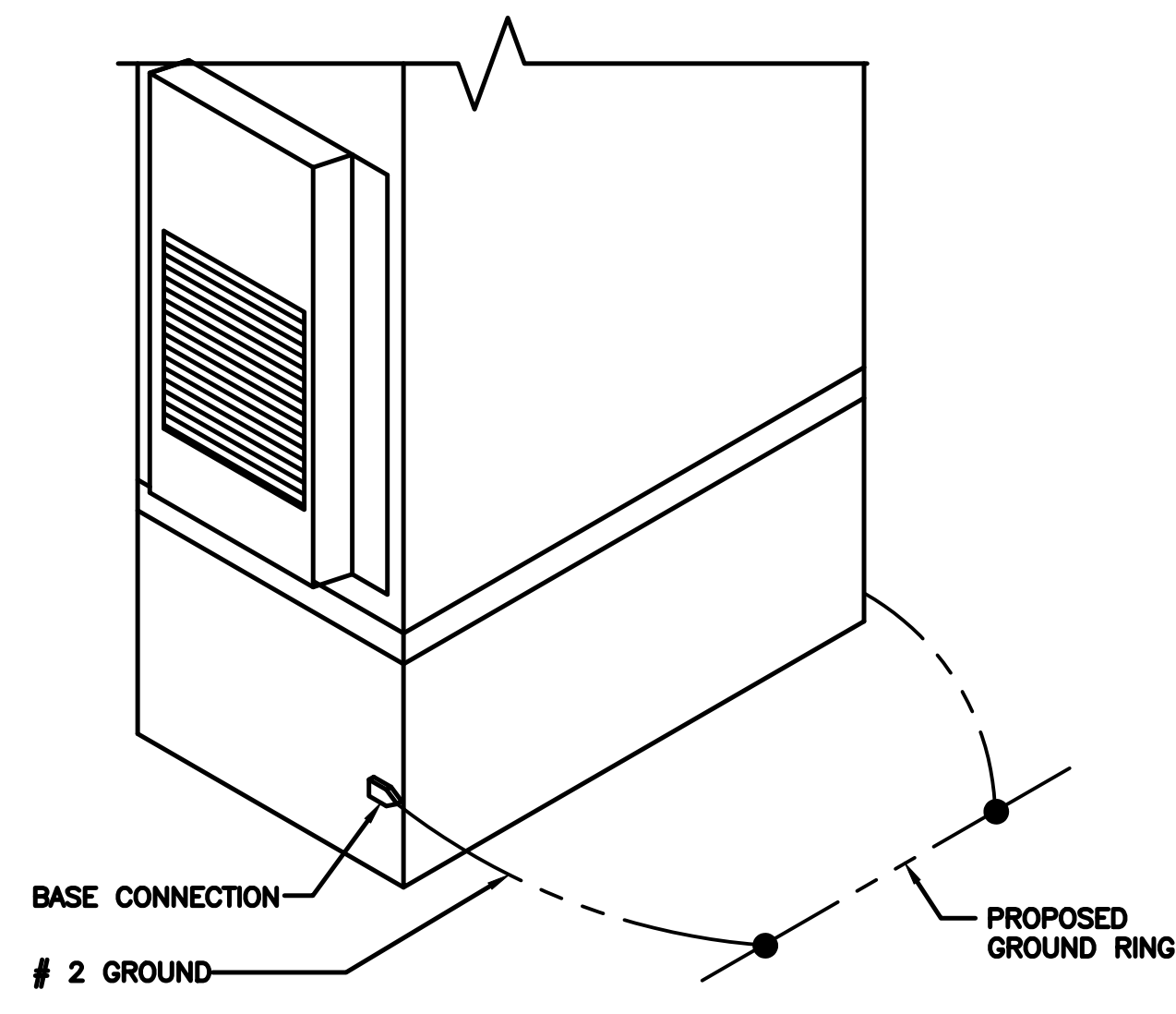

OUTDOOR CABINET GROUNDING NO SCALE 3

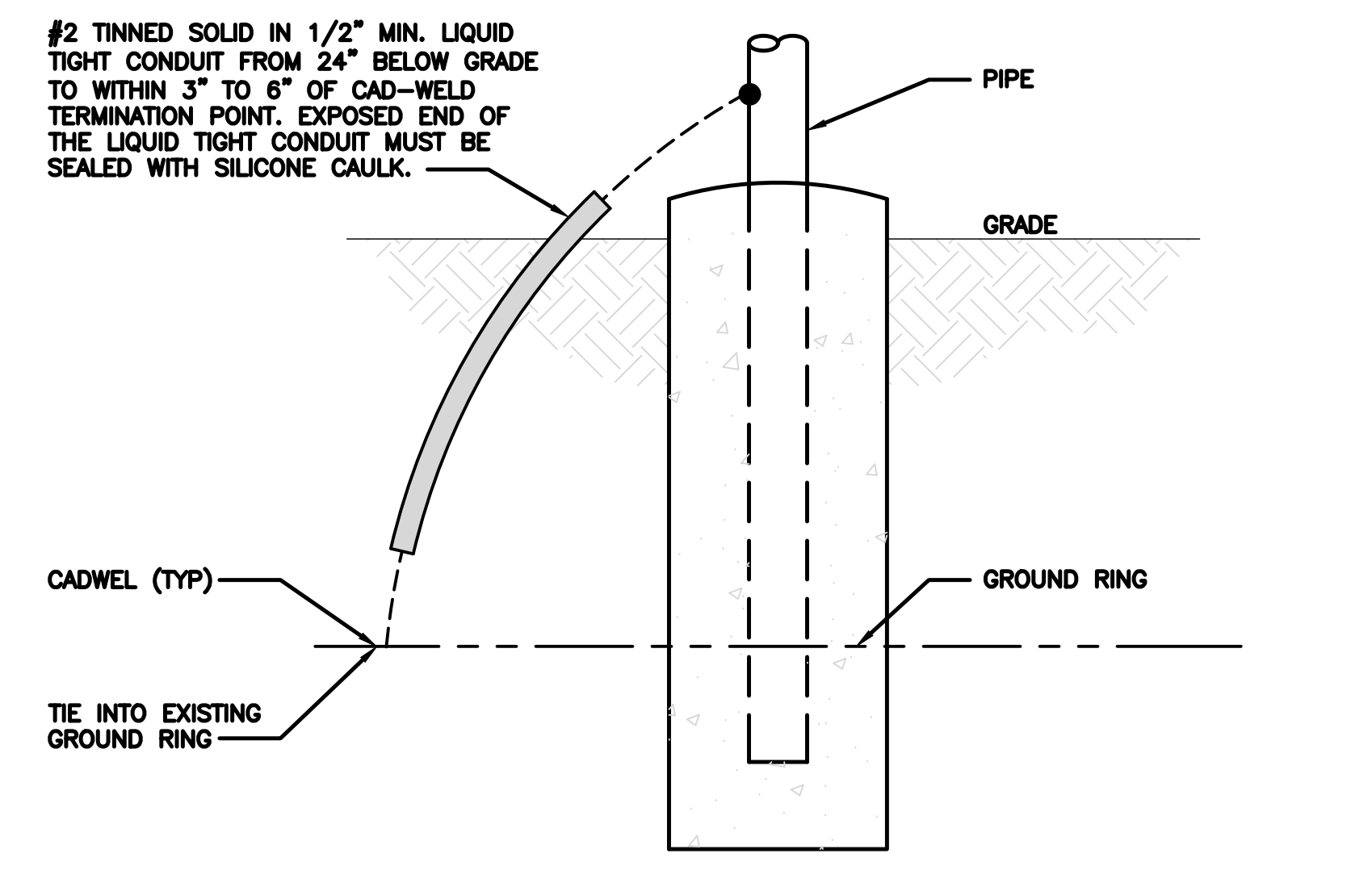

TRANSITIONING GROUND DETAIL NO SCALE 4

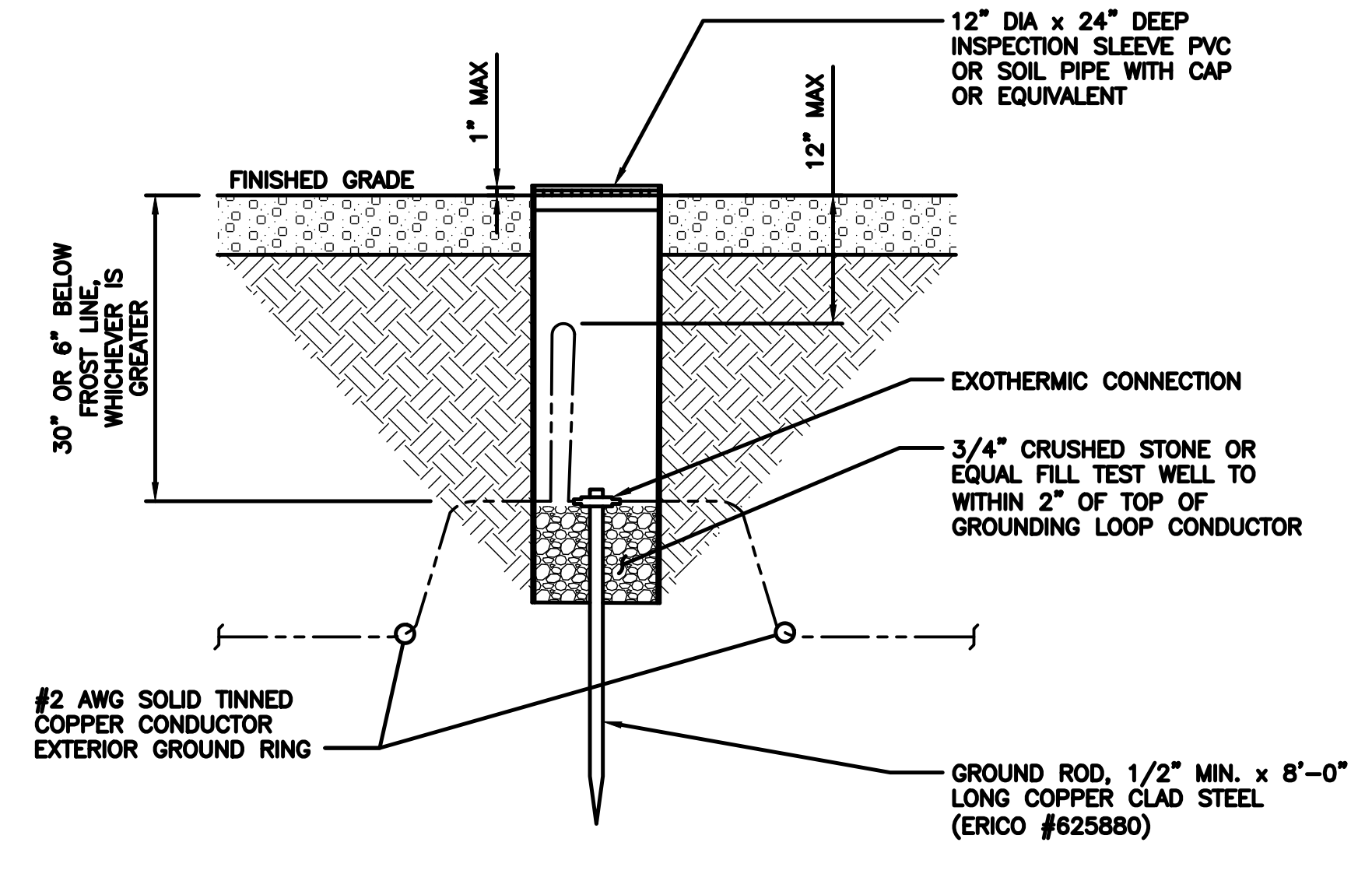

TYPICAL TEST GROUND ROD WITH INSPECTION SLEEVE NO SCALE 5

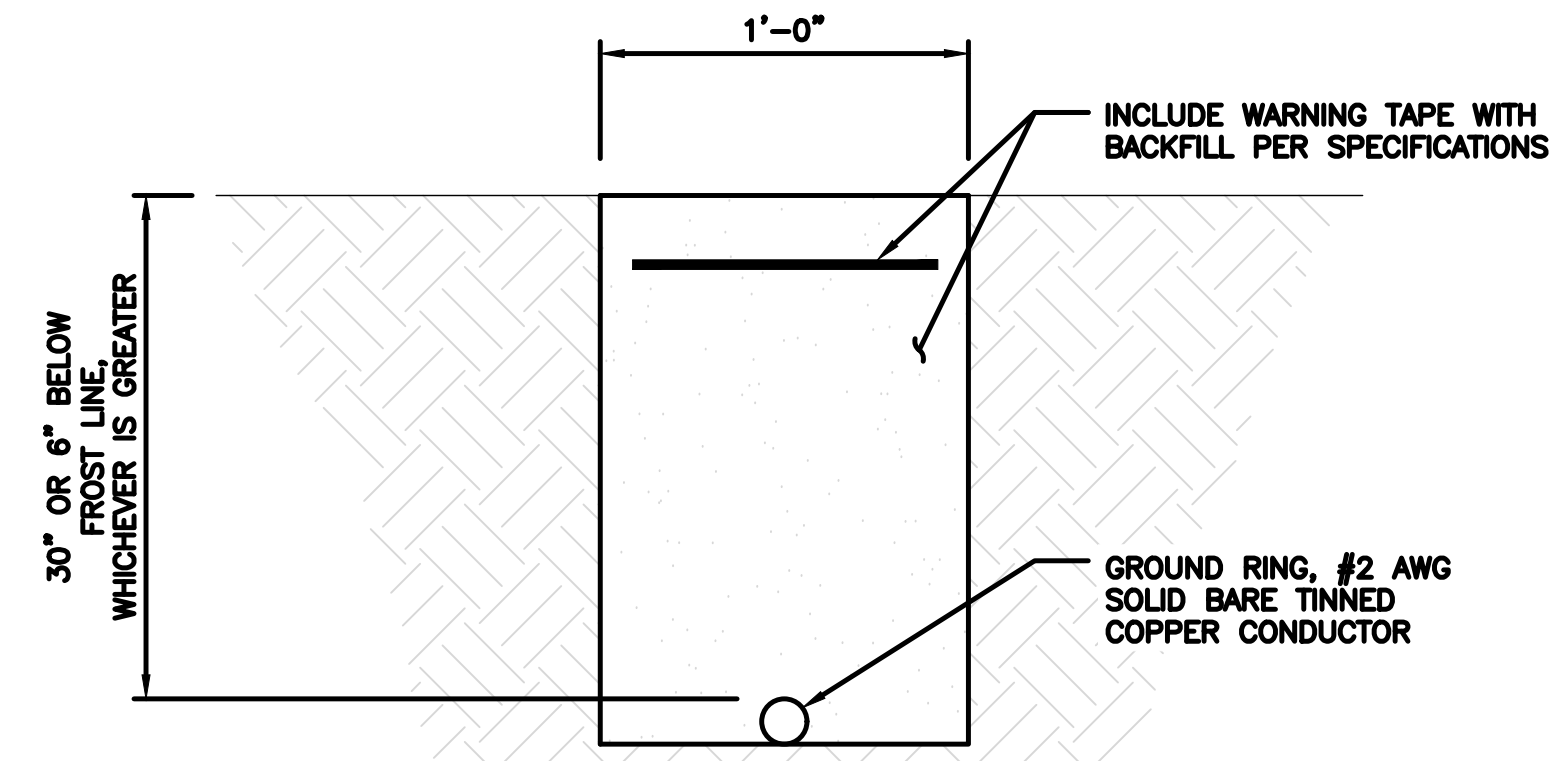

TYPICAL GROUND RING TRENCH NO SCALE 6



5701 SOUTH SANTA FE DRIVE
LITTLETON, CO 80120



45 BEECHWOOD DRIVE TEL: (978) 557-5553
N. ANDOVER, MA 01845 FAX: (978) 336-5586



IT IS A VIOLATION OF LAW FOR ANY PERSON, UNLESS THEY ARE ACTING UNDER THE DIRECTION OF A LICENSED PROFESSIONAL ENGINEER, TO ALTER THIS DOCUMENT.

DRAWN BY: PS CHECKED BY: SMA APPROVED BY: DPH

RFDS REV #: 0

PRELIMINARY DOCUMENTS

SUBMITTALS		
REV	DATE	DESCRIPTION
A	11/15/2021	ISSUED FOR REVIEW
B	01/21/2022	ISSUED FOR REVIEW

A&E PROJECT NUMBER
BOBOS00592A

DISH Wireless L.L.C.
PROJECT INFORMATION
BOBOS00592A
CROWN CASTLE BU#841273
344 ROUTE 6
NORTH TRURO, MA 02652

SHEET TITLE
GROUNDING DETAILS

SHEET NUMBER
G-2

1. EXOTHERMIC WELD (2) TWO, #2 AWG BARE TINNED SOLID COPPER CONDUCTORS TO GROUND BAR. ROUTE CONDUCTORS TO BURIED GROUND RING AND PROVIDE PARALLEL EXOTHERMIC WELD.
2. ALL EXTERIOR GROUNDING HARDWARE SHALL BE STAINLESS STEEL 3/8" DIAMETER OR LARGER. ALL HARDWARE 18-8 STAINLESS STEEL INCLUDING LOCK WASHERS, COAT ALL SURFACES WITH AN ANTI-OXIDANT COMPOUND BEFORE MATING.
3. FOR GROUND BOND TO STEEL ONLY: COAT ALL SURFACES WITH AN ANTI-OXIDANT COMPOUND BEFORE MATING.
4. DO NOT INSTALL CABLE GROUNDING KIT AT A BEND AND ALWAYS DIRECT GROUND CONDUCTOR DOWN TO GROUNDING BUS.
5. NUT & WASHER SHALL BE PLACED ON THE FRONT SIDE OF THE GROUND BAR AND BOLTED ON THE BACK SIDE.
6. ALL GROUNDING PARTS AND EQUIPMENT TO BE SUPPLIED AND INSTALLED BY CONTRACTOR.
7. THE CONTRACTOR SHALL BE RESPONSIBLE FOR INSTALLING ADDITIONAL GROUND BAR AS REQUIRED.
8. ENSURE THE WIRE INSULATION TERMINATION IS WITHIN 1/8" OF THE BARREL (NO SHINERS).

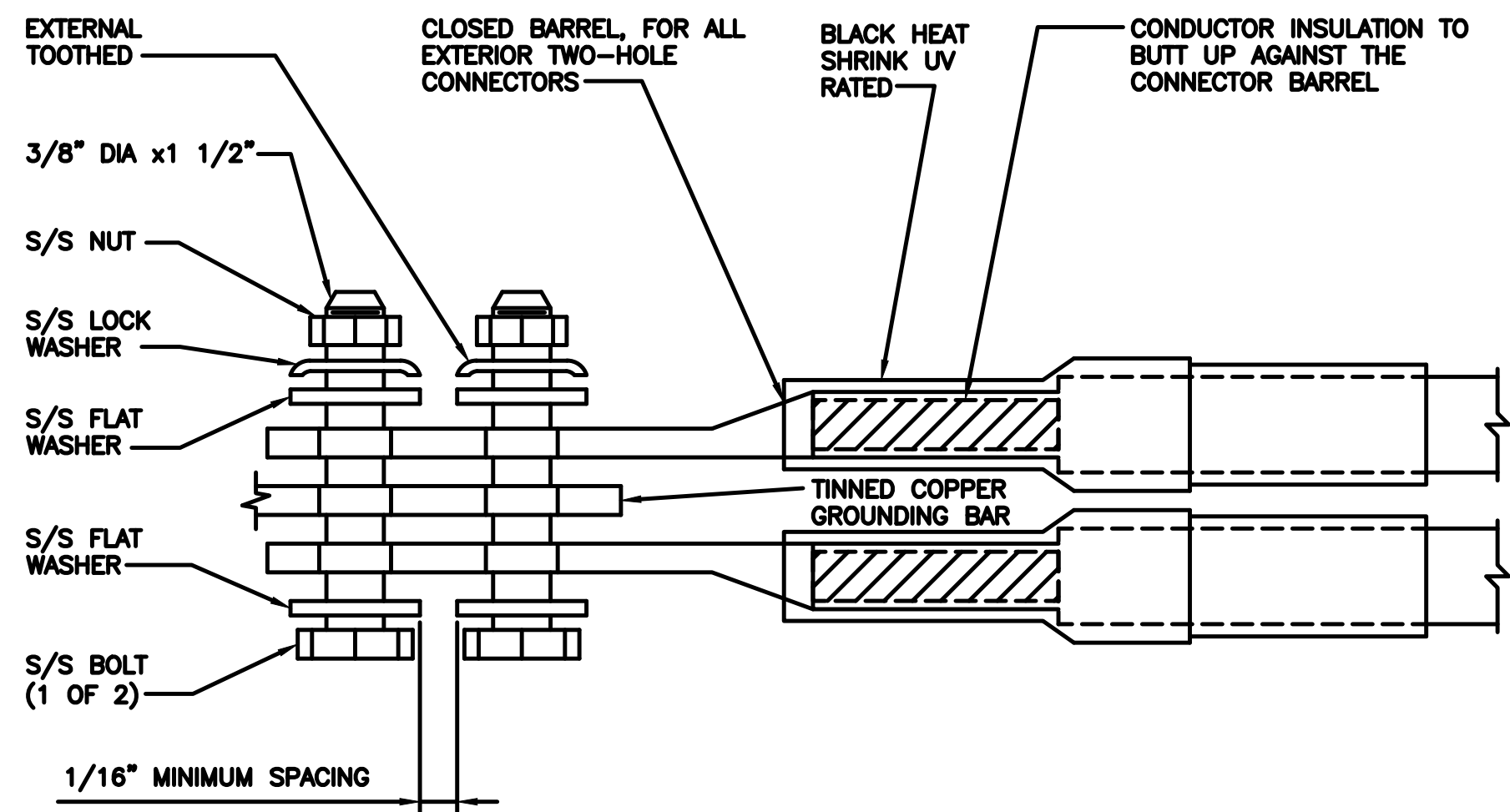

TYPICAL GROUNDING NOTES

NO SCALE

1

TYPICAL EXTERIOR TWO HOLE LUG

NO SCALE

2

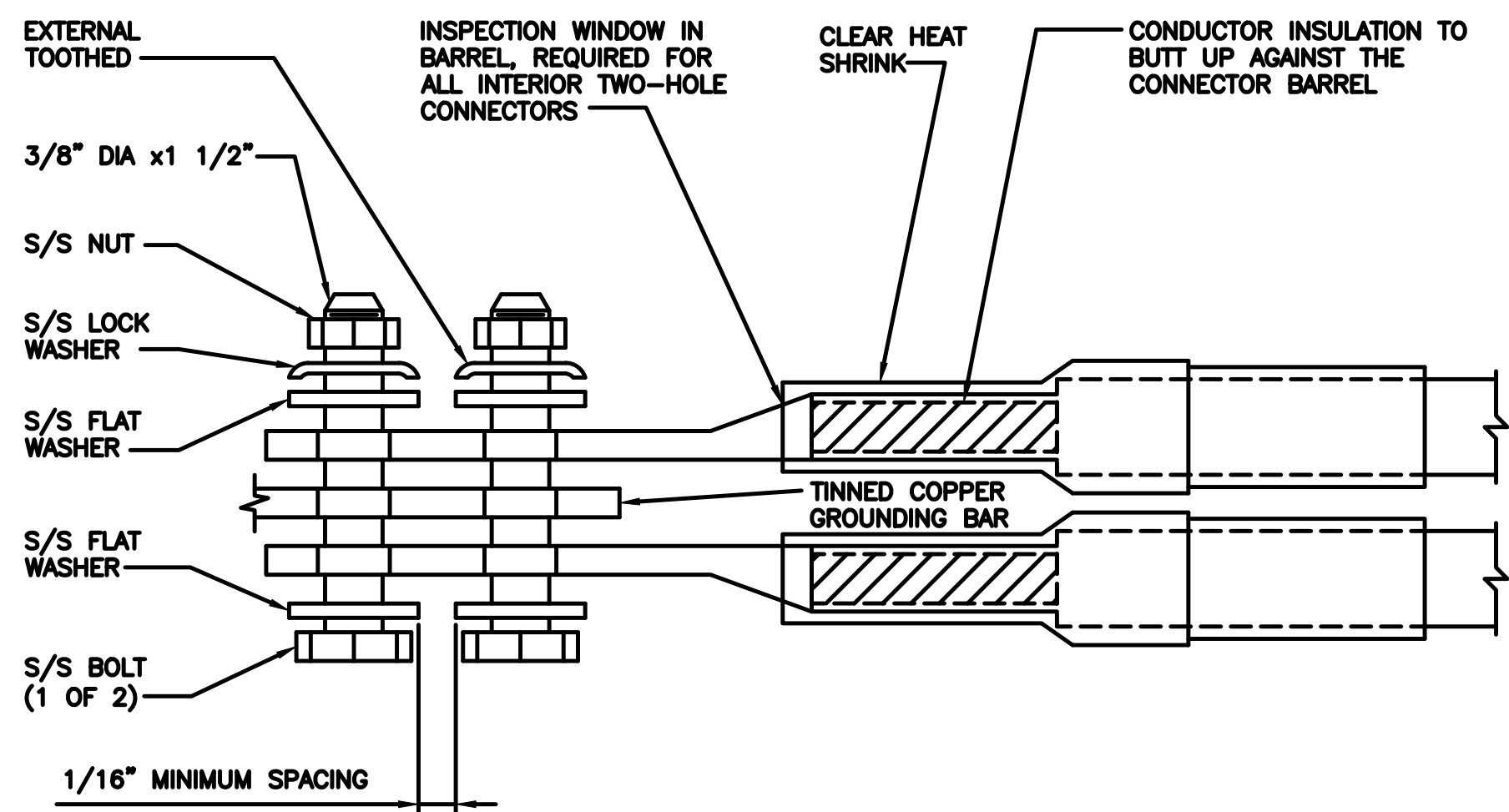

TYPICAL INTERIOR TWO HOLE LUG

NO SCALE

3

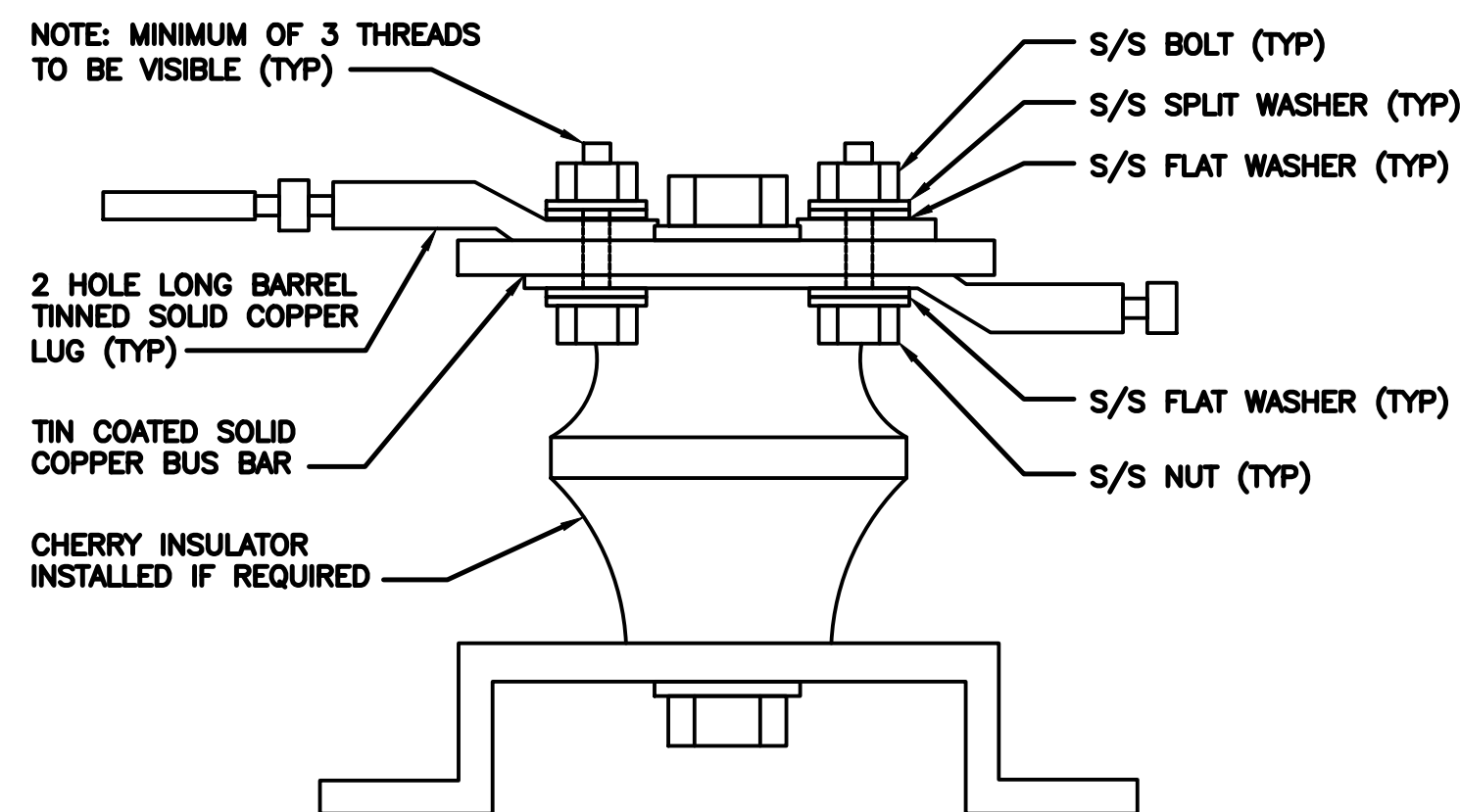

LUG DETAIL

NO SCALE

4

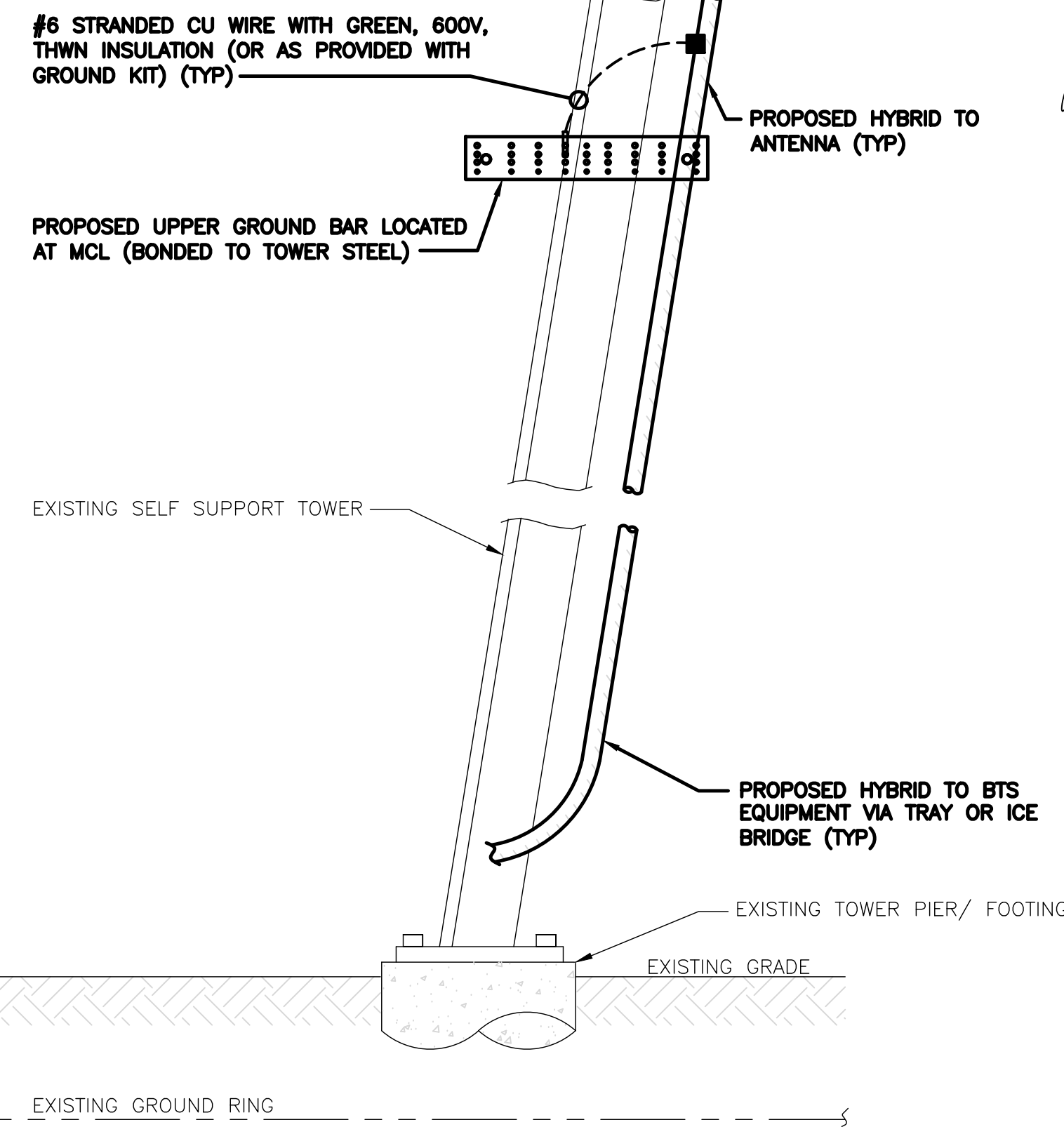

NOTES:

1. ONLY MECHANICAL CONNECTIONS ARE ALLOWED TO BE MADE TO TOWERS. ALL MECHANICAL CONNECTIONS SHALL BE TREATED WITH AN ANTI-OXIDANT COATING.
2. ALL TOWER GROUNDING SYSTEMS SHALL COMPLY WITH THE REQUIREMENTS OF THE RECOGNIZED EDITION OF ANSI/TIA 222 AND NFPA 780.

TYPICAL ANTENNA CABLE GROUNDING

NO SCALE

5



5701 SOUTH SANTA FE DRIVE
LITTLETON, CO 80120



45 BEECHWOOD DRIVE TEL: (978) 557-5553
N. ANDOVER, MA 01845 FAX: (978) 336-5586

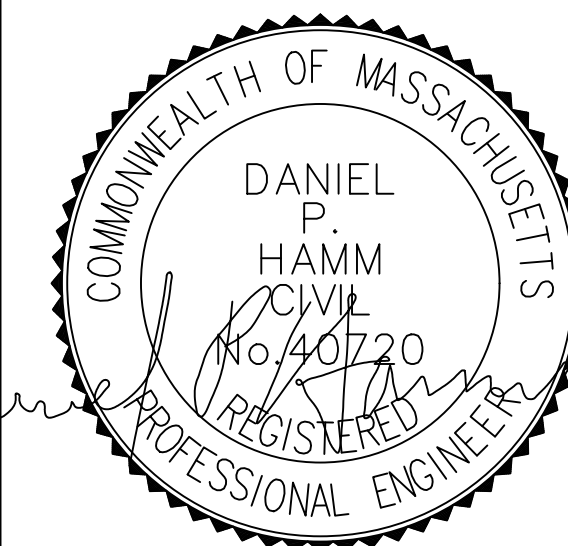

IT IS A VIOLATION OF LAW FOR ANY PERSON, UNLESS THEY ARE ACTING UNDER THE DIRECTION OF A LICENSED PROFESSIONAL ENGINEER, TO ALTER THIS DOCUMENT.

DRAWN BY: PS CHECKED BY: SMA APPROVED BY: DPH

RFDS REV #: 0

PRELIMINARY DOCUMENTS

SUBMITTALS		
REV	DATE	DESCRIPTION
A	11/15/2021	ISSUED FOR REVIEW
B	01/21/2022	ISSUED FOR REVIEW

A&E PROJECT NUMBER
BOBOS00592A

DISH Wireless L.L.C.
PROJECT INFORMATION
BOBOS00592A
CROWN CASTLE BU#841273
344 ROUTE 6
NORTH TRURO, MA 02652

SHEET TITLE
GROUNDING DETAILS

SHEET NUMBER
G-3

HYBRID/DISCREET CABLES

3/4" TAPE WIDTHS WITH 3/4" SPACING

LOW-BAND RRH
(600 MHz N71 BASEBAND) +
(850 MHz N26 BAND) +
(700 MHz N29 BAND) - OPTIONAL PER MARKET
ADD FREQUENCY COLOR TO SECTOR BAND
(CBRS WILL USE YELLOW BAND)

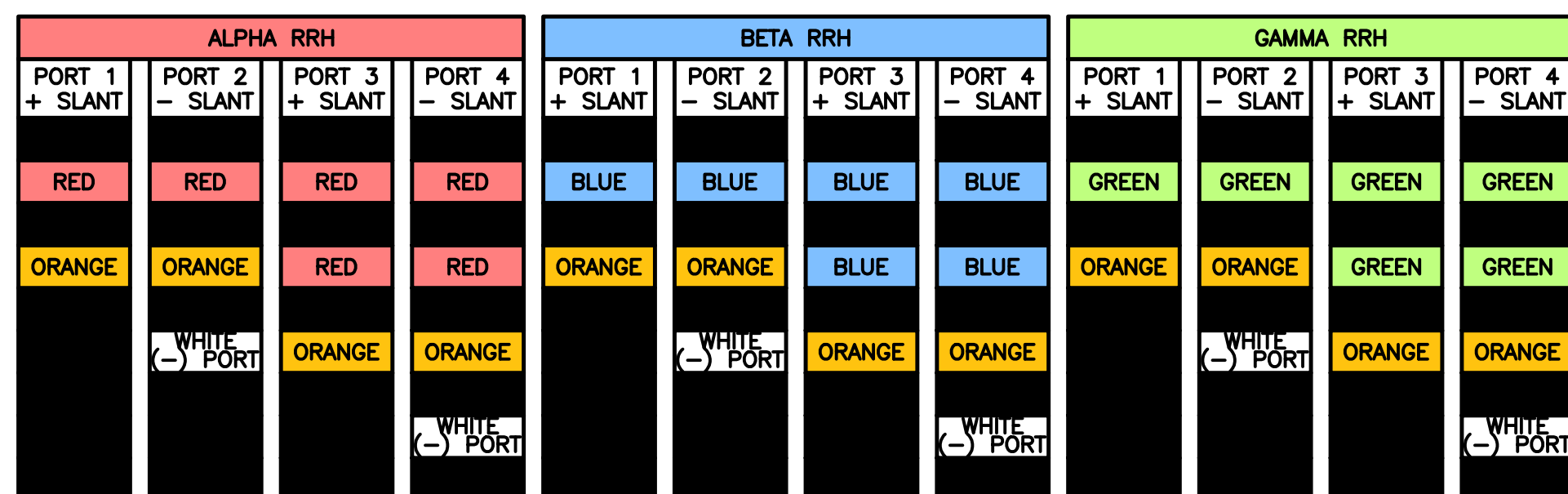

MID-BAND RRH
(AWS BANDS N66+N70)
ADD FREQUENCY COLOR TO SECTOR BAND
(CBRS WILL USE YELLOW BANDS)

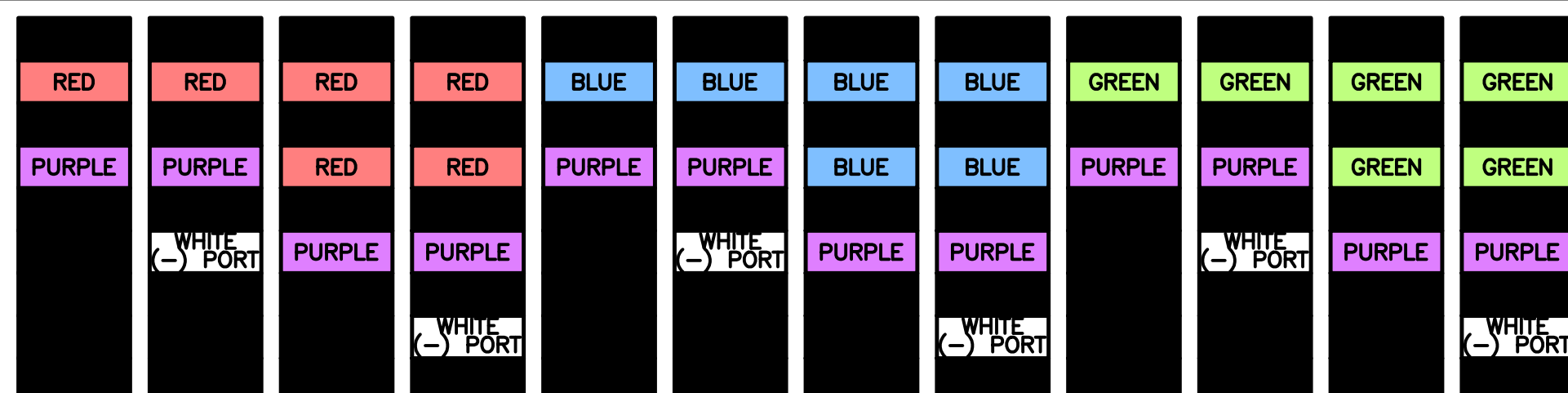

HYBRID/DISCREET CABLES

INCLUDE SECTOR BANDS BEING SUPPORTED
ALONG WITH FREQUENCY BANDS.

EXAMPLE 1 - HYBRID, OR DISCREET, SUPPORTS
ALL SECTORS, BOTH LOW-BANDS AND
MID-BANDS.

EXAMPLE 2 - HYBRID, OR DISCREET, SUPPORTS
CBRS ONLY, ALL SECTORS.

EXAMPLE 3 - MAIN COAX WITH GROUND
MOUNTED RRHS.

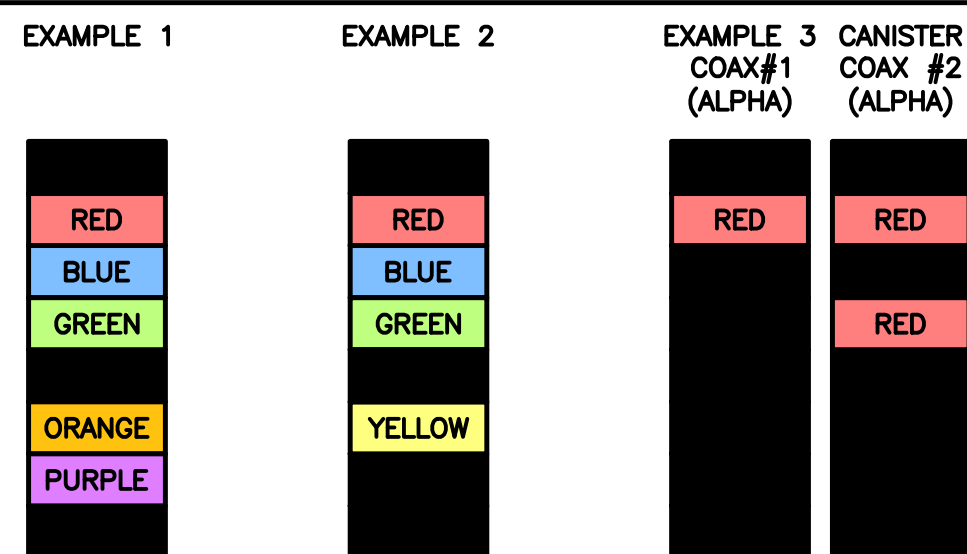

FIBER JUMPERS TO RRHS

LOW-BAND HHR FIBER CABLES HAVE SECTOR
STRIPE ONLY.

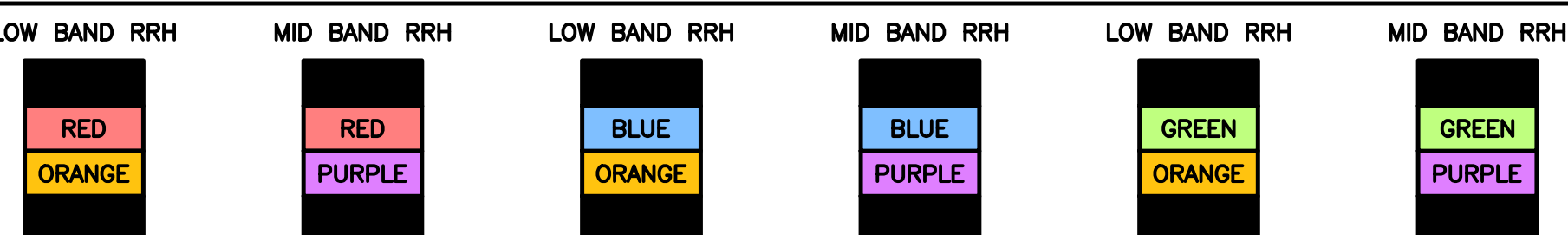

POWER CABLES TO RRHS

LOW-BAND RRH POWER CABLES HAVE SECTOR
STRIPE ONLY.

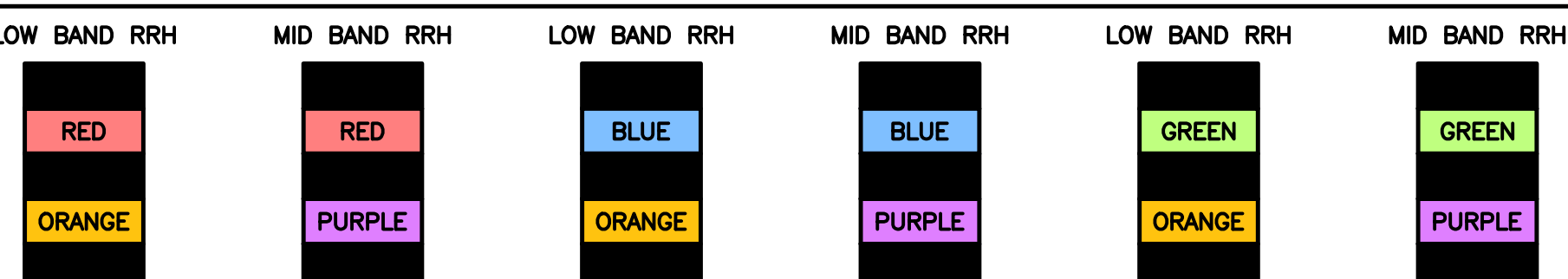

RET MOTORS AT ANTENNAS

RET CONTROL IS HANDLED BY THE MID-BAND
RRH WHEN ONE SET OF RET PORTS EXIST ON
ANTENNA.

SEPARATE RET CABLES ARE USED WHEN
ANTENNA PORTS PROVIDE INPUTS FOR BOTH
LOW AND MID BANDS.

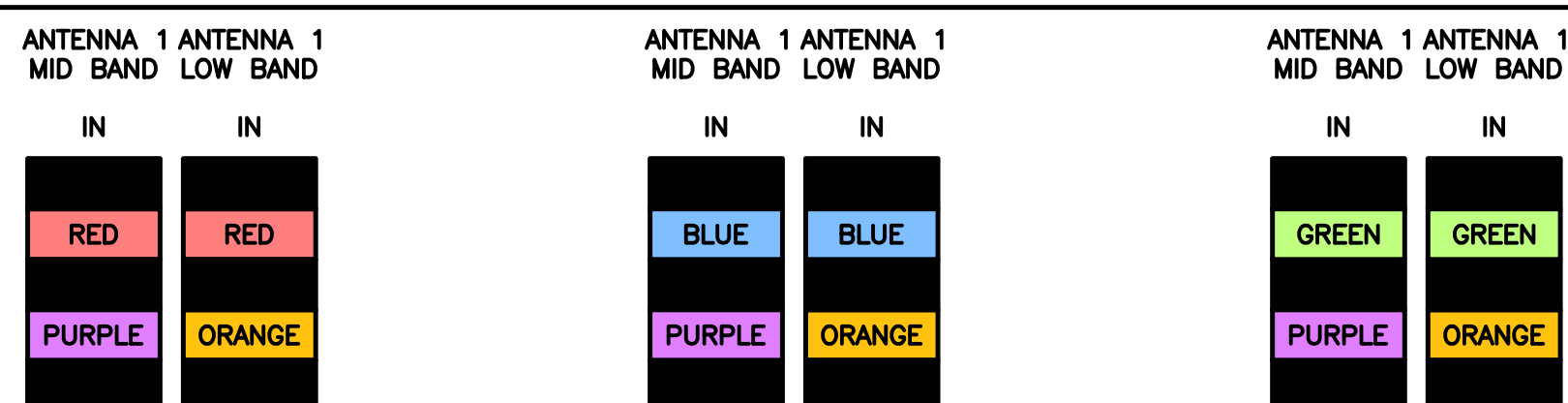

MICROWAVE RADIO LINKS

LINKS WILL HAVE A 1.5-2 INCH WHITE WRAP
WITH THE AZIMUTH COLOR OVERLAPPING IN THE
MIDDLE.
ADD ADDITIONAL SECTOR COLOR BANDS FOR
EACH ADDITIONAL MW RADIO.

MICROWAVE CABLES WILL REQUIRE P-TOUCH
LABELS INSIDE THE CABINET TO IDENTIFY THE
LOCAL AND REMOTE SITE ID'S.

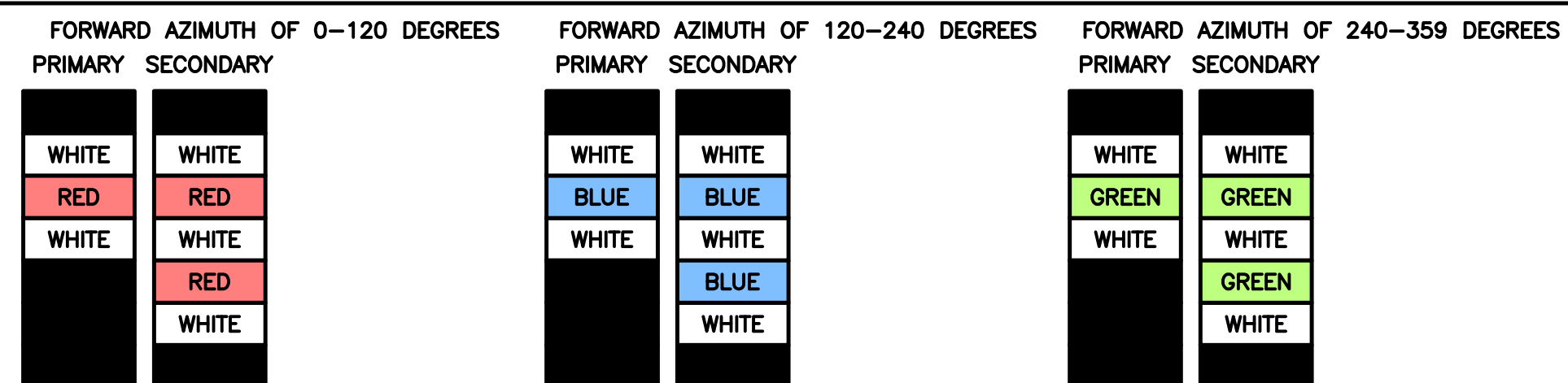

RF CABLE COLOR CODES

NO SCALE

1

NOT USED

NO SCALE

4

LOW BANDS (N71+N26)
OPTIONAL - (N29)



AWS
(N66+N70+H-BLOCK)



CBRS TECH
(3 GHz)

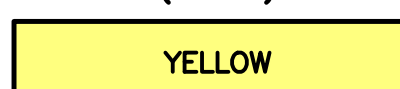

NEGATIVE SLANT PORT
ON ANT/RRH



ALPHA SECTOR



BETA SECTOR



GAMMA SECTOR



COLOR IDENTIFIER

NO SCALE

2

NOT USED

NO SCALE

3

dish
wireless.

5701 SOUTH SANTA FE DRIVE
LITTLETON, CO 80120

HG
HUDSON
Design Group LLC

45 BEECHWOOD DRIVE TEL: (978) 557-5553
N. ANDOVER, MA 01845 FAX: (978) 336-5586

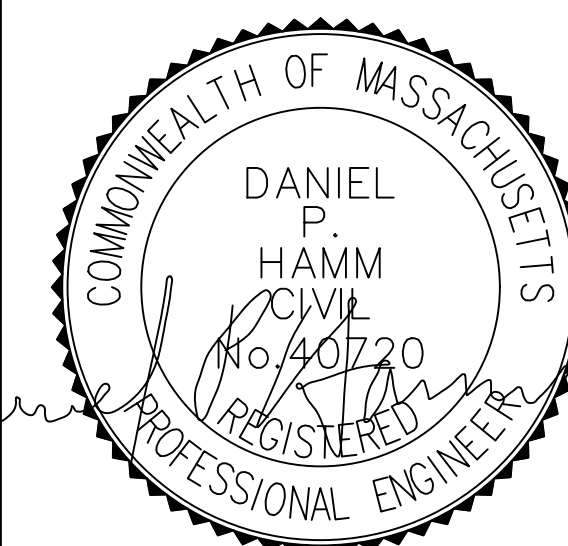

IT IS A VIOLATION OF LAW FOR ANY PERSON,
UNLESS THEY ARE ACTING UNDER THE DIRECTION
OF A LICENSED PROFESSIONAL ENGINEER,
TO ALTER THIS DOCUMENT.

DRAWN BY: CHECKED BY: APPROVED BY:

PS SMA DPH

RFDS REV #: 0

**PRELIMINARY
DOCUMENTS**

SUBMITTALS

REV	DATE	DESCRIPTION
A	11/15/2021	ISSUED FOR REVIEW
B	01/21/2022	ISSUED FOR REVIEW

A&E PROJECT NUMBER

BOBOS00592A

DISH Wireless L.L.C.
PROJECT INFORMATION
BOBOS00592A
CROWN CASTLE BU#841273
344 ROUTE 6
NORTH TRURO, MA 02652

SHEET TITLE
RF
CABLE COLOR CODE

SHEET NUMBER

RF-1

EXOTHERMIC CONNECTION
 MECHANICAL CONNECTION
 BUSS BAR INSULATOR
 CHEMICAL ELECTROLYTIC GROUNDING SYSTEM
 TEST CHEMICAL ELECTROLYTIC GROUNDING SYSTEM
 EXOTHERMIC WITH INSPECTION SLEEVE
 GROUNDING BAR
 GROUND ROD
 TEST GROUND ROD WITH INSPECTION SLEEVE
 SINGLE POLE SWITCH
 DUPLEX RECEPTACLE
 DUPLEX GFCI RECEPTACLE
 FLUORESCENT LIGHTING FIXTURE (2) TWO LAMPS 48-T8
 SMOKE DETECTION (DC)
 EMERGENCY LIGHTING (DC)
 SECURITY LIGHT W/PHOTOCELL LITHONIA ALXW
 LED-1-25A400/51K-SR4-120-PE-DBBTXD
 CHAIN LINK FENCE
 WOOD/WROUGHT IRON FENCE
 WALL STRUCTURE
 LEASE AREA
 PROPERTY LINE (PL)
 SETBACKS
 ICE BRIDGE
 CABLE TRAY
 WATER LINE
 UNDERGROUND POWER
 UNDERGROUND TELCO
 OVERHEAD POWER
 OVERHEAD TELCO
 UNDERGROUND TELCO/POWER
 ABOVE GROUND POWER
 ABOVE GROUND TELCO
 ABOVE GROUND TELCO/POWER
 WORKPOINT

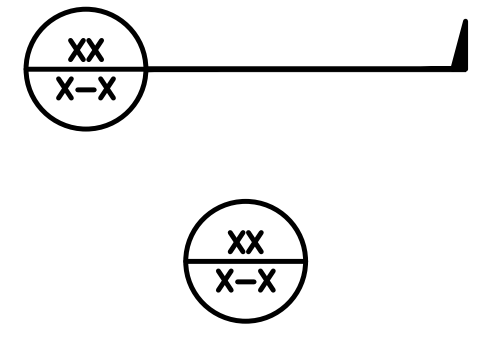
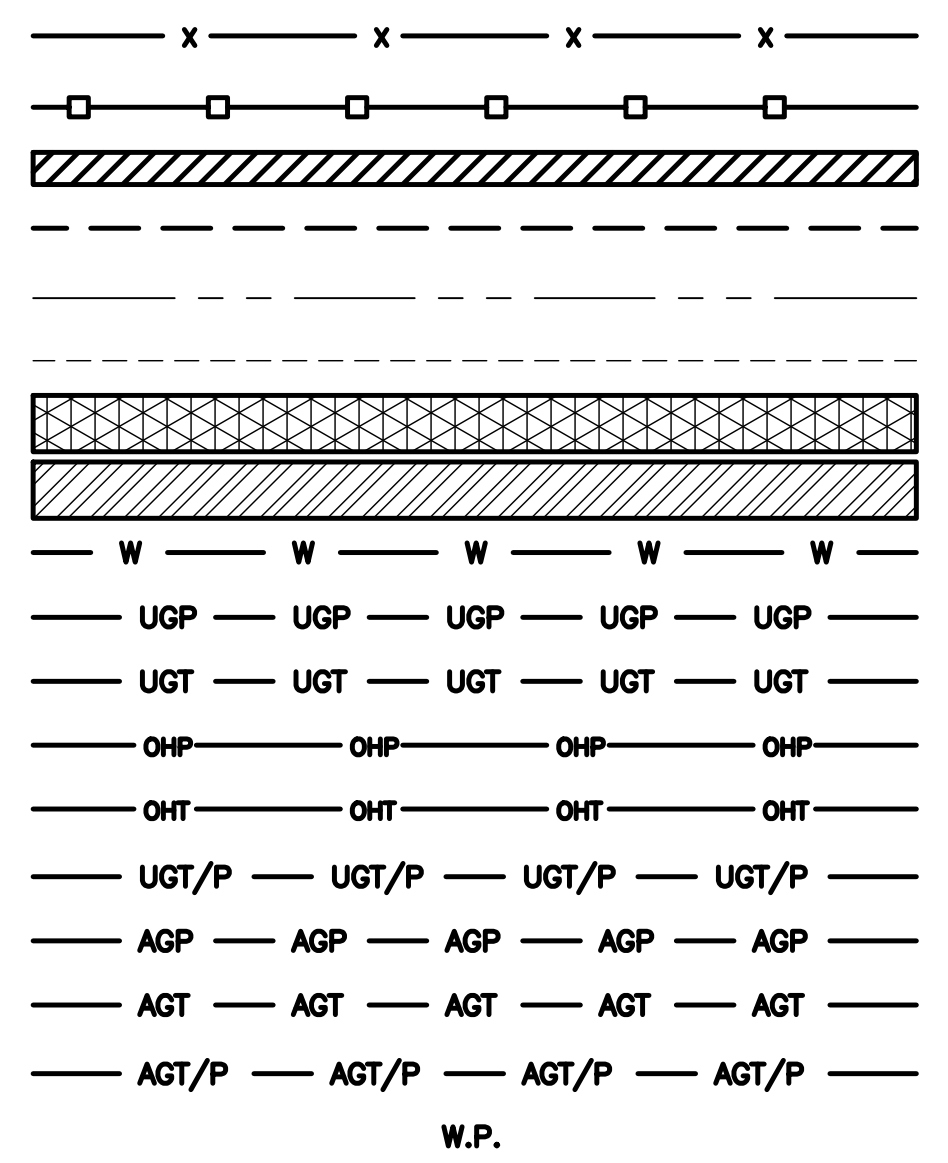
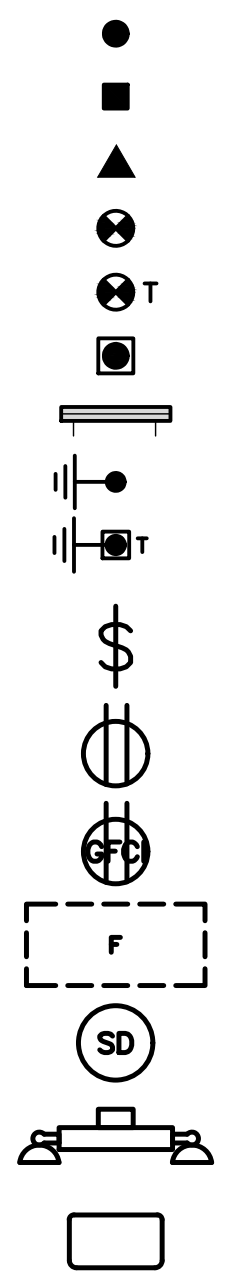

SECTION REFERENCE
 DETAIL REFERENCE

LEGEND

AB ANCHOR BOLT
 ABV ABOVE
 AC ALTERNATING CURRENT
 ADDL ADDITIONAL
 AFF ABOVE FINISHED FLOOR
 AFG ABOVE FINISHED GRADE
 AGL ABOVE GROUND LEVEL
 AIC AMPERAGE INTERRUPTION CAPACITY
 ALUM ALUMINUM
 ALT ALTERNATE
 ANT ANTENNA
 APPROX APPROXIMATE
 ARCH ARCHITECTURAL
 ATS AUTOMATIC TRANSFER SWITCH
 AWG AMERICAN WIRE GAUGE
 BATT BATTERY
 BLDG BUILDING
 BLK BLOCK
 BLKG BLOCKING
 BM BEAM
 BTC BARE TINNED COPPER CONDUCTOR
 BOF BOTTOM OF FOOTING
 CAB CABINET
 CANT CANTILEVERED
 CHG CHARGING
 CLG CEILING
 CLR CLEAR
 COL COLUMN
 COMM COMMON
 CONC CONCRETE
 CONSTR CONSTRUCTION
 DBL DOUBLE
 DC DIRECT CURRENT
 DEPT DEPARTMENT
 DF DOUGLAS FIR
 DIA DIAMETER
 DIAG DIAGONAL
 DIM DIMENSION
 DWG DRAWING
 DWL DOWEL
 EA EACH
 EC ELECTRICAL CONDUCTOR
 EL ELEVATION
 ELEC ELECTRICAL
 EMT ELECTRICAL METALLIC TUBING
 ENG ENGINEER
 EQ EQUAL
 EXP EXPANSION
 EXT EXTERIOR
 EW EACH WAY
 FAB FABRICATION
 FF FINISH FLOOR
 FG FINISH GRADE
 FIF FACILITY INTERFACE FRAME
 FIN FINISH(ED)
 FLR FLOOR
 FDN FOUNDATION
 FOC FACE OF CONCRETE
 FOM FACE OF MASONRY
 FOS FACE OF STUD
 FOW FACE OF WALL
 FS FINISH SURFACE
 FT FOOT
 FTG FOOTING
 GA GAUGE
 GEN GENERATOR
 GFCI GROUND FAULT CIRCUIT INTERRUPTER
 GLB GLUE LAMINATED BEAM
 GLV GALVANIZED
 GPS GLOBAL POSITIONING SYSTEM
 GND GROUND
 GSM GLOBAL SYSTEM FOR MOBILE
 HDG HOT DIPPED GALVANIZED
 HDR HEADER
 HGR HANGER
 HVAC HEAT/VENTILATION/AIR CONDITIONING
 HT HEIGHT
 IGR INTERIOR GROUND RING

IN INCH
 INT INTERIOR
 LB(S) POUND(S)
 LF LINEAR FEET
 LTE LONG TERM EVOLUTION
 MAS MASONRY
 MAX MAXIMUM
 MB MACHINE BOLT
 MECH MECHANICAL
 MFR MANUFACTURER
 MGB MASTER GROUND BAR
 MIN MINIMUM
 MISC MISCELLANEOUS
 MTL METAL
 MTS MANUAL TRANSFER SWITCH
 MW MICROWAVE
 NEC NATIONAL ELECTRIC CODE
 NM NEWTON METERS
 NO. NUMBER
 # NUMBER
 NTS NOT TO SCALE
 OC ON-CENTER
 OSHA OCCUPATIONAL SAFETY AND HEALTH ADMINISTRATION
 OPNG OPENING
 P/C PRECAST CONCRETE
 PCS PERSONAL COMMUNICATION SERVICES
 PCU PRIMARY CONTROL UNIT
 PRC PRIMARY RADIO CABINET
 PP POLARIZING PRESERVING
 PSF POUNDS PER SQUARE FOOT
 PSI POUNDS PER SQUARE INCH
 PT PRESSURE TREATED
 PWR POWER CABINET
 QTY QUANTITY
 RAD RADIUS
 RECT RECTIFIER
 REF REFERENCE
 REINF REINFORCEMENT
 REQ'D REQUIRED
 RET REMOTE ELECTRIC TILT
 RF RADIO FREQUENCY
 RMC RIGID METALLIC CONDUIT
 RRH REMOTE RADIO HEAD
 RRU REMOTE RADIO UNIT
 RWY RACEWAY
 SCH SCHEDULE
 SHT SHEET
 SIAD SMART INTEGRATED ACCESS DEVICE
 SIM SIMILAR
 SPEC SPECIFICATION
 SQ SQUARE
 SS STAINLESS STEEL
 STD STANDARD
 STL STEEL
 TEMP TEMPORARY
 THK THICKNESS
 TMA TOWER MOUNTED AMPLIFIER
 TN TOE NAIL
 TOA TOP OF ANTENNA
 TOC TOP OF CURB
 TOF TOP OF FOUNDATION
 TOP TOP OF PLATE (PARAPET)
 TOS TOP OF STEEL
 TOW TOP OF WALL
 TVSS TRANSIENT VOLTAGE SURGE SUPPRESSION
 TYP TYPICAL
 UG UNDERGROUND
 UL UNDERWRITERS LABORATORY
 UNO UNLESS NOTED OTHERWISE
 UMTS UNIVERSAL MOBILE TELECOMMUNICATIONS SYSTEM
 UPS UNINTERRUPTIBLE POWER SYSTEM (DC POWER PLANT)
 VIF VERIFIED IN FIELD
 W WIDE
 W/ WITH
 WD WOOD
 WP WEATHERPROOF
 WT WEIGHT

ABBREVIATIONS



5701 SOUTH SANTA FE DRIVE
 LITTLETON, CO 80120



45 BEECHWOOD DRIVE N. ANDOVER, MA 01845 TEL: (978) 557-5553 FAX: (978) 336-5586



IT IS A VIOLATION OF LAW FOR ANY PERSON, UNLESS THEY ARE ACTING UNDER THE DIRECTION OF A LICENSED PROFESSIONAL ENGINEER, TO ALTER THIS DOCUMENT.

DRAWN BY: PS CHECKED BY: SMA APPROVED BY: DPH

RFDS REV #: 0

PRELIMINARY DOCUMENTS

SUBMITTALS		
REV	DATE	DESCRIPTION
A	11/15/2021	ISSUED FOR REVIEW
B	01/21/2022	ISSUED FOR REVIEW

A&E PROJECT NUMBER
 BOBOS00592A

DISH Wireless L.L.C.
 PROJECT INFORMATION
 BOBOS00592A
 CROWN CASTLE BU#841273
 344 ROUTE 6
 NORTH TRURO, MA 02652

SHEET TITLE
 LEGEND AND ABBREVIATIONS

SHEET NUMBER
 GN-1

SITE ACTIVITY REQUIREMENTS:

1. NOTICE TO PROCEED – NO WORK SHALL COMMENCE PRIOR TO CONTRACTOR RECEIVING A WRITTEN NOTICE TO PROCEED (NTP) AND THE ISSUANCE OF A PURCHASE ORDER. PRIOR TO ACCESSING/ENTERING THE SITE YOU MUST CONTACT THE DISH Wireless L.L.C. AND TOWER OWNER NOC & THE DISH Wireless L.L.C. AND TOWER OWNER CONSTRUCTION MANAGER.
2. "LOOK UP" – DISH Wireless L.L.C. AND TOWER OWNER SAFETY CLIMB REQUIREMENT:
THE INTEGRITY OF THE SAFETY CLIMB AND ALL COMPONENTS OF THE CLIMBING FACILITY SHALL BE CONSIDERED DURING ALL STAGES OF DESIGN, INSTALLATION, AND INSPECTION. TOWER MODIFICATION, MOUNT REINFORCEMENTS, AND/OR EQUIPMENT INSTALLATIONS SHALL NOT COMPROMISE THE INTEGRITY OR FUNCTIONAL USE OF THE SAFETY CLIMB OR ANY COMPONENTS OF THE CLIMBING FACILITY ON THE STRUCTURE. THIS SHALL INCLUDE, BUT NOT BE LIMITED TO: PINCHING OF THE WIRE ROPE, BENDING OF THE WIRE ROPE FROM ITS SUPPORTS, DIRECT CONTACT OR CLOSE PROXIMITY TO THE WIRE ROPE WHICH MAY CAUSE FRICTIONAL WEAR, IMPACT TO THE ANCHORAGE POINTS IN ANY WAY, OR TO IMPEDE/BLOCK ITS INTENDED USE. ANY COMPROMISED SAFETY CLIMB, INCLUDING EXISTING CONDITIONS MUST BE TAGGED OUT AND REPORTED TO YOUR DISH Wireless L.L.C. AND DISH Wireless L.L.C. AND TOWER OWNER POC OR CALL THE NOC TO GENERATE A SAFETY CLIMB MAINTENANCE AND CONTRACTOR NOTICE TICKET.
3. PRIOR TO THE START OF CONSTRUCTION, ALL REQUIRED JURISDICTIONAL PERMITS SHALL BE OBTAINED. THIS INCLUDES, BUT IS NOT LIMITED TO, BUILDING, ELECTRICAL, MECHANICAL, FIRE, FLOOD ZONE, ENVIRONMENTAL, AND ZONING. AFTER ONSITE ACTIVITIES AND CONSTRUCTION ARE COMPLETED, ALL REQUIRED PERMITS SHALL BE SATISFIED AND CLOSED OUT ACCORDING TO LOCAL JURISDICTIONAL REQUIREMENTS.
4. ALL CONSTRUCTION MEANS AND METHODS; INCLUDING BUT NOT LIMITED TO, ERECTION PLANS, RIGGING PLANS, CLIMBING PLANS, AND RESCUE PLANS SHALL BE THE RESPONSIBILITY OF THE GENERAL CONTRACTOR RESPONSIBLE FOR THE EXECUTION OF THE WORK CONTAINED HEREIN, AND SHALL MEET ANSI/ASSE A10.48 (LATEST EDITION); FEDERAL, STATE, AND LOCAL REGULATIONS; AND ANY APPLICABLE INDUSTRY CONSENSUS STANDARDS RELATED TO THE CONSTRUCTION ACTIVITIES BEING PERFORMED. ALL RIGGING PLANS SHALL ADHERE TO ANSI/ASSE A10.48 (LATEST EDITION) AND DISH Wireless L.L.C. AND TOWER OWNER STANDARDS, INCLUDING THE REQUIRED INVOLVEMENT OF A QUALIFIED ENGINEER FOR CLASS IV CONSTRUCTION, TO CERTIFY THE SUPPORTING STRUCTURE(S) IN ACCORDANCE WITH ANSI/TIA-322 (LATEST EDITION).
5. ALL SITE WORK TO COMPLY WITH DISH Wireless L.L.C. AND TOWER OWNER INSTALLATION STANDARDS FOR CONSTRUCTION ACTIVITIES ON DISH Wireless L.L.C. AND TOWER OWNER TOWER SITE AND LATEST VERSION OF ANSI/TIA-1019-A-2012 "STANDARD FOR INSTALLATION, ALTERATION, AND MAINTENANCE OF ANTENNA SUPPORTING STRUCTURES AND ANTENNAS."
6. IF THE SPECIFIED EQUIPMENT CAN NOT BE INSTALLED AS SHOWN ON THESE DRAWINGS, THE CONTRACTOR SHALL PROPOSE AN ALTERNATIVE INSTALLATION FOR APPROVAL BY DISH Wireless L.L.C. AND TOWER OWNER PRIOR TO PROCEEDING WITH ANY SUCH CHANGE OF INSTALLATION.
7. ALL MATERIALS FURNISHED AND INSTALLED SHALL BE IN STRICT ACCORDANCE WITH ALL APPLICABLE CODES, REGULATIONS AND ORDINANCES. CONTRACTOR SHALL ISSUE ALL APPROPRIATE NOTICES AND COMPLY WITH ALL LAWS, ORDINANCES, RULES, REGULATIONS AND LAWFUL ORDERS OF ANY PUBLIC AUTHORITY REGARDING THE PERFORMANCE OF THE WORK. ALL WORK CARRIED OUT SHALL COMPLY WITH ALL APPLICABLE MUNICIPAL AND UTILITY COMPANY SPECIFICATIONS AND LOCAL JURISDICTIONAL CODES, ORDINANCES AND APPLICABLE REGULATIONS.
8. THE CONTRACTOR SHALL INSTALL ALL EQUIPMENT AND MATERIALS IN ACCORDANCE WITH MANUFACTURER'S RECOMMENDATIONS UNLESS SPECIFICALLY STATED OTHERWISE.
9. THE CONTRACTOR SHALL CONTACT UTILITY LOCATING SERVICES INCLUDING PRIVATE LOCATES SERVICES PRIOR TO THE START OF CONSTRUCTION.
10. ALL EXISTING ACTIVE SEWER, WATER, GAS, ELECTRIC AND OTHER UTILITIES WHERE ENCOUNTERED IN THE WORK, SHALL BE PROTECTED AT ALL TIMES AND WHERE REQUIRED FOR THE PROPER EXECUTION OF THE WORK, SHALL BE RELOCATED AS DIRECTED BY CONTRACTOR. EXTREME CAUTION SHOULD BE USED BY THE CONTRACTOR WHEN EXCAVATING OR DRILLING PIERS AROUND OR NEAR UTILITIES. CONTRACTOR SHALL PROVIDE SAFETY TRAINING FOR THE WORKING CREW. THIS WILL INCLUDE BUT NOT BE LIMITED TO A) FALL PROTECTION B) CONFINED SPACE C) ELECTRICAL SAFETY D) TRENCHING AND EXCAVATION E) CONSTRUCTION SAFETY PROCEDURES.
11. ALL SITE WORK SHALL BE AS INDICATED ON THE STAMPED CONSTRUCTION DRAWINGS AND DISH PROJECT SPECIFICATIONS, LATEST APPROVED REVISION.
12. CONTRACTOR SHALL KEEP THE SITE FREE FROM ACCUMULATING WASTE MATERIAL, DEBRIS, AND TRASH AT THE COMPLETION OF THE WORK. IF NECESSARY, RUBBISH, STUMPS, DEBRIS, STICKS, STONES AND OTHER REFUSE SHALL BE REMOVED FROM THE SITE AND DISPOSED OF LEGALLY.
13. ALL EXISTING INACTIVE SEWER, WATER, GAS, ELECTRIC AND OTHER UTILITIES, WHICH INTERFERE WITH THE EXECUTION OF THE WORK, SHALL BE REMOVED AND/OR CAPPED, PLUGGED OR OTHERWISE DISCONTINUED AT POINTS WHICH WILL NOT INTERFERE WITH THE EXECUTION OF THE WORK, SUBJECT TO THE APPROVAL OF DISH Wireless L.L.C. AND TOWER OWNER, AND/OR LOCAL UTILITIES.
14. THE CONTRACTOR SHALL PROVIDE SITE SIGNAGE IN ACCORDANCE WITH THE TECHNICAL SPECIFICATION FOR SITE SIGNAGE REQUIRED BY LOCAL JURISDICTION AND SIGNAGE REQUIRED ON INDIVIDUAL PIECES OF EQUIPMENT, ROOMS, AND SHELTERS.
15. THE SITE SHALL BE GRADED TO CAUSE SURFACE WATER TO FLOW AWAY FROM THE CARRIER'S EQUIPMENT AND TOWER AREAS.
16. THE SUB GRADE SHALL BE COMPACTED AND BROUGHT TO A SMOOTH UNIFORM GRADE PRIOR TO FINISHED SURFACE APPLICATION.
17. THE AREAS OF THE OWNERS PROPERTY DISTURBED BY THE WORK AND NOT COVERED BY THE TOWER, EQUIPMENT OR DRIVEWAY, SHALL BE GRADED TO A UNIFORM SLOPE, AND STABILIZED TO PREVENT EROSION AS SPECIFIED ON THE CONSTRUCTION DRAWINGS AND/OR PROJECT SPECIFICATIONS.
18. CONTRACTOR SHALL MINIMIZE DISTURBANCE TO EXISTING SITE DURING CONSTRUCTION. EROSION CONTROL MEASURES, IF REQUIRED DURING CONSTRUCTION, SHALL BE IN CONFORMANCE WITH THE LOCAL GUIDELINES FOR EROSION AND SEDIMENT CONTROL.
19. THE CONTRACTOR SHALL PROTECT EXISTING IMPROVEMENTS, PAVEMENTS, CURBS, LANDSCAPING AND STRUCTURES. ANY DAMAGED PART SHALL BE REPAIRED AT CONTRACTOR'S EXPENSE TO THE SATISFACTION OF OWNER.
20. CONTRACTOR SHALL LEGALLY AND PROPERLY DISPOSE OF ALL SCRAP MATERIALS SUCH AS COAXIAL CABLES AND OTHER ITEMS REMOVED FROM THE EXISTING FACILITY. ANTENNAS AND RADIOS REMOVED SHALL BE RETURNED TO THE OWNER'S DESIGNATED LOCATION.
21. CONTRACTOR SHALL LEAVE PREMISES IN CLEAN CONDITION. TRASH AND DEBRIS SHOULD BE REMOVED FROM SITE ON A DAILY BASIS.
22. NO FILL OR EMBANKMENT MATERIAL SHALL BE PLACED ON FROZEN GROUND. FROZEN MATERIALS, SNOW OR ICE SHALL NOT BE PLACED IN ANY FILL OR EMBANKMENT.

GENERAL NOTES:

1. FOR THE PURPOSE OF CONSTRUCTION DRAWING, THE FOLLOWING DEFINITIONS SHALL APPLY:
CONTRACTOR: GENERAL CONTRACTOR RESPONSIBLE FOR CONSTRUCTION
CARRIER: DISH Wireless L.L.C.
TOWER OWNER: TOWER OWNER
2. THESE DRAWINGS HAVE BEEN PREPARED USING STANDARDS OF PROFESSIONAL CARE AND COMPLETENESS NORMALLY EXERCISED UNDER SIMILAR CIRCUMSTANCES BY REPUTABLE ENGINEERS IN THIS OR SIMILAR LOCALITIES. IT IS ASSUMED THAT THE WORK DEPICTED WILL BE PERFORMED BY AN EXPERIENCED CONTRACTOR AND/OR WORKPEOPLE WHO HAVE A WORKING KNOWLEDGE OF THE APPLICABLE CODE STANDARDS AND REQUIREMENTS AND OF INDUSTRY ACCEPTED STANDARD GOOD PRACTICE. AS NOT EVERY CONDITION OR ELEMENT IS (OR CAN BE) EXPLICITLY SHOWN ON THESE DRAWINGS, THE CONTRACTOR SHALL USE INDUSTRY ACCEPTED STANDARD GOOD PRACTICE FOR MISCELLANEOUS WORK NOT EXPLICITLY SHOWN.
3. THESE DRAWINGS REPRESENT THE FINISHED STRUCTURE. THEY DO NOT INDICATE THE MEANS OR METHODS OF CONSTRUCTION. THE CONTRACTOR SHALL BE SOLELY RESPONSIBLE FOR THE CONSTRUCTION MEANS, METHODS, TECHNIQUES, SEQUENCES, AND PROCEDURES. THE CONTRACTOR SHALL PROVIDE ALL MEASURES NECESSARY FOR PROTECTION OF LIFE AND PROPERTY DURING CONSTRUCTION. SUCH MEASURES SHALL INCLUDE, BUT NOT BE LIMITED TO, BRACING, FORMWORK, SHORING, ETC. SITE VISITS BY THE ENGINEER OR HIS REPRESENTATIVE WILL NOT INCLUDE INSPECTION OF THESE ITEMS AND IS FOR STRUCTURAL OBSERVATION OF THE FINISHED STRUCTURE ONLY.
4. NOTES AND DETAILS IN THE CONSTRUCTION DRAWINGS SHALL TAKE PRECEDENCE OVER GENERAL NOTES AND TYPICAL DETAILS. WHERE NO DETAILS ARE SHOWN, CONSTRUCTION SHALL CONFORM TO SIMILAR WORK ON THE PROJECT, AND/OR AS PROVIDED FOR IN THE CONTRACT DOCUMENTS. WHERE DISCREPANCIES OCCUR BETWEEN PLANS, DETAILS, GENERAL NOTES, AND SPECIFICATIONS, THE GREATER, MORE STRICT REQUIREMENTS, SHALL GOVERN. IF FURTHER CLARIFICATION IS REQUIRED CONTACT THE ENGINEER OF RECORD.
5. SUBSTANTIAL EFFORT HAS BEEN MADE TO PROVIDE ACCURATE DIMENSIONS AND MEASUREMENTS ON THE DRAWINGS TO ASSIST IN THE FABRICATION AND/OR PLACEMENT OF CONSTRUCTION ELEMENTS BUT IT IS THE SOLE RESPONSIBILITY OF THE CONTRACTOR TO FIELD VERIFY THE DIMENSIONS, MEASUREMENTS, AND/OR CLEARANCES SHOWN IN THE CONSTRUCTION DRAWINGS PRIOR TO FABRICATION OR CUTTING OF ANY NEW OR EXISTING CONSTRUCTION ELEMENTS. IF IT IS DETERMINED THAT THERE ARE DISCREPANCIES AND/OR CONFLICTS WITH THE CONSTRUCTION DRAWINGS THE ENGINEER OF RECORD IS TO BE NOTIFIED AS SOON AS POSSIBLE.
6. PRIOR TO THE SUBMISSION OF BIDS, THE BIDDING CONTRACTOR SHALL VISIT THE CELL SITE TO FAMILIARIZE WITH THE EXISTING CONDITIONS AND TO CONFIRM THAT THE WORK CAN BE ACCOMPLISHED AS SHOWN ON THE CONSTRUCTION DRAWINGS. ANY DISCREPANCY FOUND SHALL BE BROUGHT TO THE ATTENTION OF CARRIER POC AND TOWER OWNER.
7. ALL MATERIALS FURNISHED AND INSTALLED SHALL BE IN STRICT ACCORDANCE WITH ALL APPLICABLE CODES, REGULATIONS AND ORDINANCES. CONTRACTOR SHALL ISSUE ALL APPROPRIATE NOTICES AND COMPLY WITH ALL LAWS, ORDINANCES, RULES, REGULATIONS AND LAWFUL ORDERS OF ANY PUBLIC AUTHORITY REGARDING THE PERFORMANCE OF THE WORK. ALL WORK CARRIED OUT SHALL COMPLY WITH ALL APPLICABLE MUNICIPAL AND UTILITY COMPANY SPECIFICATIONS AND LOCAL JURISDICTIONAL CODES, ORDINANCES AND APPLICABLE REGULATIONS.
8. UNLESS NOTED OTHERWISE, THE WORK SHALL INCLUDE FURNISHING MATERIALS, EQUIPMENT, APPURTENANCES AND LABOR NECESSARY TO COMPLETE ALL INSTALLATIONS AS INDICATED ON THE DRAWINGS.
9. THE CONTRACTOR SHALL INSTALL ALL EQUIPMENT AND MATERIALS IN ACCORDANCE WITH MANUFACTURER'S RECOMMENDATIONS UNLESS SPECIFICALLY STATED OTHERWISE.
10. IF THE SPECIFIED EQUIPMENT CAN NOT BE INSTALLED AS SHOWN ON THESE DRAWINGS, THE CONTRACTOR SHALL PROPOSE AN ALTERNATIVE INSTALLATION FOR APPROVAL BY THE CARRIER AND TOWER OWNER PRIOR TO PROCEEDING WITH ANY SUCH CHANGE OF INSTALLATION.
11. CONTRACTOR IS TO PERFORM A SITE INVESTIGATION, BEFORE SUBMITTING BIDS, TO DETERMINE THE BEST ROUTING OF ALL CONDUITS FOR POWER, AND TELCO AND FOR GROUNDING CABLES AS SHOWN IN THE POWER, TELCO, AND GROUNDING PLAN DRAWINGS.
12. THE CONTRACTOR SHALL PROTECT EXISTING IMPROVEMENTS, PAVEMENTS, CURBS, LANDSCAPING AND STRUCTURES. ANY DAMAGED PART SHALL BE REPAIRED AT CONTRACTOR'S EXPENSE TO THE SATISFACTION OF DISH Wireless L.L.C. AND TOWER OWNER
13. CONTRACTOR SHALL LEGALLY AND PROPERLY DISPOSE OF ALL SCRAP MATERIALS SUCH AS COAXIAL CABLES AND OTHER ITEMS REMOVED FROM THE EXISTING FACILITY. ANTENNAS REMOVED SHALL BE RETURNED TO THE OWNER'S DESIGNATED LOCATION.
14. CONTRACTOR SHALL LEAVE PREMISES IN CLEAN CONDITION. TRASH AND DEBRIS SHOULD BE REMOVED FROM SITE ON A DAILY BASIS.



5701 SOUTH SANTA FE DRIVE
LITTLETON, CO 80120



45 BEECHWOOD DRIVE N. ANDOVER, MA 01845 TEL: (978) 557-5553 FAX: (978) 336-5586

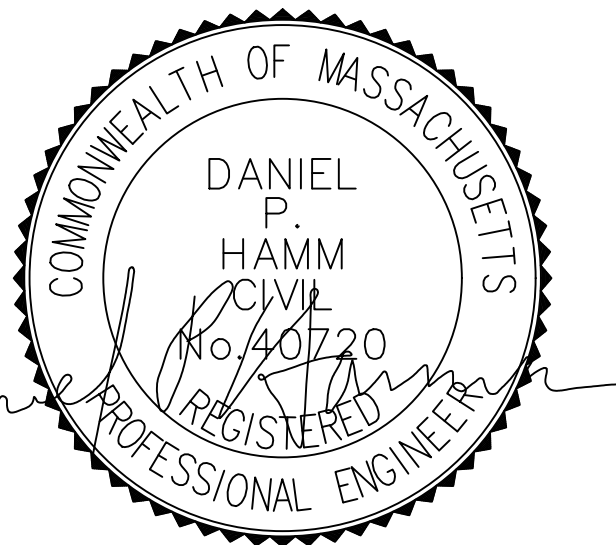

IT IS A VIOLATION OF LAW FOR ANY PERSON, UNLESS THEY ARE ACTING UNDER THE DIRECTION OF A LICENSED PROFESSIONAL ENGINEER, TO ALTER THIS DOCUMENT.

DRAWN BY:	CHECKED BY:	APPROVED BY:
PS	SMA	DPH

RFDS REV #: 0

PRELIMINARY DOCUMENTS

SUBMITTALS		
REV	DATE	DESCRIPTION
A	11/15/2021	ISSUED FOR REVIEW
B	01/21/2022	ISSUED FOR REVIEW

A&E PROJECT NUMBER
BOBOS00592A

DISH Wireless L.L.C.
PROJECT INFORMATION
BOBOS00592A
CROWN CASTLE BU#841273
344 ROUTE 6
NORTH TRURO, MA 02652

SHEET TITLE
GENERAL NOTES

SHEET NUMBER
GN-2

CONCRETE, FOUNDATIONS, AND REINFORCING STEEL:

1. ALL CONCRETE WORK SHALL BE IN ACCORDANCE WITH THE ACI 301, ACI 318, ACI 336, ASTM A184, ASTM A185 AND THE DESIGN AND CONSTRUCTION SPECIFICATION FOR CAST-IN-PLACE CONCRETE.
2. UNLESS NOTED OTHERWISE, SOIL BEARING PRESSURE USED FOR DESIGN OF SLABS AND FOUNDATIONS IS ASSUMED TO BE 1000 psf.
3. ALL CONCRETE SHALL HAVE A MINIMUM COMPRESSIVE STRENGTH (f'c) OF 3000 psi AT 28 DAYS, UNLESS NOTED OTHERWISE. NO MORE THAN 90 MINUTES SHALL ELAPSE FROM BATCH TIME TO TIME OF PLACEMENT UNLESS APPROVED BY THE ENGINEER OF RECORD. TEMPERATURE OF CONCRETE SHALL NOT EXCEED 90°F AT TIME OF PLACEMENT.
4. CONCRETE EXPOSED TO FREEZE-THAW CYCLES SHALL CONTAIN AIR ENTRAINING ADMIXTURES. AMOUNT OF AIR ENTRAINMENT TO BE BASED ON SIZE OF AGGREGATE AND F3 CLASS EXPOSURE (VERY SEVERE). CEMENT USED TO BE TYPE II PORTLAND CEMENT WITH A MAXIMUM WATER-TO-CEMENT RATIO (W/C) OF 0.45.
5. ALL STEEL REINFORCING SHALL CONFORM TO ASTM A615. ALL WELDED WIRE FABRIC (WWF) SHALL CONFORM TO ASTM A185. ALL SPLICES SHALL BE CLASS "B" TENSION SPLICES, UNLESS NOTED OTHERWISE. ALL HOOKS SHALL BE STANDARD 90 DEGREE HOOKS, UNLESS NOTED OTHERWISE. YIELD STRENGTH (Fy) OF STANDARD DEFORMED BARS ARE AS FOLLOWS:
 - #4 BARS AND SMALLER 40 ksi
 - #5 BARS AND LARGER 60 ksi
6. THE FOLLOWING MINIMUM CONCRETE COVER SHALL BE PROVIDED FOR REINFORCING STEEL UNLESS SHOWN OTHERWISE ON DRAWINGS:
 - CONCRETE CAST AGAINST AND PERMANENTLY EXPOSED TO EARTH 3"
 - CONCRETE EXPOSED TO EARTH OR WEATHER:
 - #6 BARS AND LARGER 2"
 - #5 BARS AND SMALLER 1-1/2"
 - CONCRETE NOT EXPOSED TO EARTH OR WEATHER:
 - SLAB AND WALLS 3/4"
 - BEAMS AND COLUMNS 1-1/2"
7. A TOOLED EDGE OR A 3/4" CHAMFER SHALL BE PROVIDED AT ALL EXPOSED EDGES OF CONCRETE, UNLESS NOTED OTHERWISE, IN ACCORDANCE WITH ACI 301 SECTION 4.2.4.

ELECTRICAL INSTALLATION NOTES:

1. ALL ELECTRICAL WORK SHALL BE PERFORMED IN ACCORDANCE WITH THE PROJECT SPECIFICATIONS, NEC AND ALL APPLICABLE FEDERAL, STATE, AND LOCAL CODES/ORDINANCES.
2. CONDUIT ROUTINGS ARE SCHEMATIC. CONTRACTOR SHALL INSTALL CONDUITS SO THAT ACCESS TO EQUIPMENT IS NOT BLOCKED AND TRIP HAZARDS ARE ELIMINATED.
3. WIRING, RACEWAY AND SUPPORT METHODS AND MATERIALS SHALL COMPLY WITH THE REQUIREMENTS OF THE NEC.
4. ALL CIRCUITS SHALL BE SEGREGATED AND MAINTAIN MINIMUM CABLE SEPARATION AS REQUIRED BY THE NEC.
 - 4.1. ALL EQUIPMENT SHALL BEAR THE UNDERWRITERS LABORATORIES LABEL OF APPROVAL, AND SHALL CONFORM TO REQUIREMENT OF THE NATIONAL ELECTRICAL CODE.
 - 4.2. ALL OVERCURRENT DEVICES SHALL HAVE AN INTERRUPTING CURRENT RATING THAT SHALL BE GREATER THAN THE SHORT CIRCUIT CURRENT TO WHICH THEY ARE SUBJECTED, 22,000 AIC MINIMUM. VERIFY AVAILABLE SHORT CIRCUIT CURRENT DOES NOT EXCEED THE RATING OF ELECTRICAL EQUIPMENT IN ACCORDANCE WITH ARTICLE 110.24 NEC OR THE MOST CURRENT ADOPTED CODE PRE THE GOVERNING JURISDICTION.
5. EACH END OF EVERY POWER PHASE CONDUCTOR, GROUNDING CONDUCTOR, AND TELCO CONDUCTOR OR CABLE SHALL BE LABELED WITH COLOR-CODED INSULATION OR ELECTRICAL TAPE (3M BRAND, 1/2" PLASTIC ELECTRICAL TAPE WITH UV PROTECTION, OR EQUAL). THE IDENTIFICATION METHOD SHALL CONFORM WITH NEC AND OSHA.
6. ALL ELECTRICAL COMPONENTS SHALL BE CLEARLY LABELED WITH LAMICOID TAGS SHOWING THEIR RATED VOLTAGE, PHASE CONFIGURATION, WIRE CONFIGURATION, POWER OR AMPACITY RATING AND BRANCH CIRCUIT ID NUMBERS (i.e. PANEL BOARD AND CIRCUIT ID'S).
7. PANEL BOARDS (ID NUMBERS) SHALL BE CLEARLY LABELED WITH PLASTIC LABELS.
8. TIE WRAPS ARE NOT ALLOWED.
9. ALL POWER AND EQUIPMENT GROUND WIRING IN TUBING OR CONDUIT SHALL BE SINGLE COPPER CONDUCTOR (#14 OR LARGER) WITH TYPE THHW, THWN, THWN-2, XHHW, XHHW-2, THW, THW-2, RHW, OR RHW-2 INSULATION UNLESS OTHERWISE SPECIFIED.
10. SUPPLEMENTAL EQUIPMENT GROUND WIRING LOCATED INDOORS SHALL BE SINGLE COPPER CONDUCTOR (#6 OR LARGER) WITH TYPE THHW, THWN, THWN-2, XHHW, XHHW-2, THW, THW-2, RHW, OR RHW-2 INSULATION UNLESS OTHERWISE SPECIFIED.
11. POWER AND CONTROL WIRING IN FLEXIBLE CORD SHALL BE MULTI-CONDUCTOR, TYPE SOOW CORD (#14 OR LARGER) UNLESS OTHERWISE SPECIFIED.
12. POWER AND CONTROL WIRING FOR USE IN CABLE TRAY SHALL BE MULTI-CONDUCTOR, TYPE TC CABLE (#14 OR LARGER), WITH TYPE THHW, THWN, THWN-2, XHHW, XHHW-2, THW, THW-2, RHW, OR RHW-2 INSULATION UNLESS OTHERWISE SPECIFIED.
13. ALL POWER AND GROUNDING CONNECTIONS SHALL BE CRIMP-STYLE, COMPRESSION WIRE LUGS AND WIRE NUTS BY THOMAS AND BETTS (OR EQUAL). LUGS AND WIRE NUTS SHALL BE RATED FOR OPERATION NOT LESS THAN 75° C (90° C IF AVAILABLE).
14. RACEWAY AND CABLE TRAY SHALL BE LISTED OR LABELED FOR ELECTRICAL USE IN ACCORDANCE WITH NEMA, UL, ANSI/IEEE AND NEC.
15. ELECTRICAL METALLIC TUBING (EMT), INTERMEDIATE METAL CONDUIT (IMC), OR RIGID METAL CONDUIT (RMC) SHALL BE USED FOR EXPOSED INDOOR LOCATIONS.

16. ELECTRICAL METALLIC TUBING (EMT) OR METAL-CLAD CABLE (MC) SHALL BE USED FOR CONCEALED INDOOR LOCATIONS.
17. SCHEDULE 40 PVC UNDERGROUND ON STRAIGHTS AND SCHEDULE 80 PVC FOR ALL ELBOWS/90s AND ALL APPROVED ABOVE GRADE PVC CONDUIT.
18. LIQUID-TIGHT FLEXIBLE METALLIC CONDUIT (LIQUID-TITE FLEX) SHALL BE USED INDOORS AND OUTDOORS, WHERE VIBRATION OCCURS OR FLEXIBILITY IS NEEDED.
19. CONDUIT AND TUBING FITTINGS SHALL BE THREADED OR COMPRESSION-TYPE AND APPROVED FOR THE LOCATION USED. SET SCREW FITTINGS ARE NOT ACCEPTABLE.
20. CABINETS, BOXES AND WIRE WAYS SHALL BE LABELED FOR ELECTRICAL USE IN ACCORDANCE WITH NEMA, UL, ANSI/IEEE AND THE NEC.
21. WIREWAYS SHALL BE METAL WITH AN ENAMEL FINISH AND INCLUDE A HINGED COVER, DESIGNED TO SWING OPEN DOWNWARDS (WIREMOLD SPECMATE WIREWAY).
22. SLOTTED WIRING DUCT SHALL BE PVC AND INCLUDE COVER (PANDUIT TYPE E OR EQUAL).
23. CONDUITS SHALL BE FASTENED SECURELY IN PLACE WITH APPROVED NON-PERFORATED STRAPS AND HANGERS. EXPLOSIVE DEVICES (i.e. POWDER-ACTUATED) FOR ATTACHING HANGERS TO STRUCTURE WILL NOT BE PERMITTED. CLOSELY FOLLOW THE LINES OF THE STRUCTURE, MAINTAIN CLOSE PROXIMITY TO THE STRUCTURE AND KEEP CONDUITS IN TIGHT ENVELOPES. CHANGES IN DIRECTION TO ROUTE AROUND OBSTACLES SHALL BE MADE WITH CONDUIT OUTLET BODIES. CONDUIT SHALL BE INSTALLED IN A NEAT AND WORKMANLIKE MANNER. PARALLEL AND PERPENDICULAR TO STRUCTURE WALL AND CEILING LINES. ALL CONDUIT SHALL BE FISHED TO CLEAR OBSTRUCTIONS. ENDS OF CONDUITS SHALL BE TEMPORARILY CAPPED FLUSH TO FINISH GRADE TO PREVENT CONCRETE, PLASTER OR DIRT FROM ENTERING. CONDUITS SHALL BE RIGIDLY CLAMPED TO BOXES BY GALVANIZED MALLEABLE IRON BUSHING ON INSIDE AND GALVANIZED MALLEABLE IRON LOCKNUT ON OUTSIDE AND INSIDE.
24. EQUIPMENT CABINETS, TERMINAL BOXES, JUNCTION BOXES AND PULL BOXES SHALL BE GALVANIZED OR EPOXY-COATED SHEET STEEL. SHALL MEET OR EXCEED UL 50 AND BE RATED NEMA 1 (OR BETTER) FOR INTERIOR LOCATIONS AND NEMA 3 (OR BETTER) FOR EXTERIOR LOCATIONS.
25. METAL RECEPTACLE, SWITCH AND DEVICE BOXES SHALL BE GALVANIZED, EPOXY-COATED OR NON-CORRODING; SHALL MEET OR EXCEED UL 514A AND NEMA OS 1 AND BE RATED NEMA 1 (OR BETTER) FOR INTERIOR LOCATIONS AND WEATHER PROTECTED (WP OR BETTER) FOR EXTERIOR LOCATIONS.
26. NONMETALLIC RECEPTACLE, SWITCH AND DEVICE BOXES SHALL MEET OR EXCEED NEMA OS 2 (NEWEST REVISION) AND BE RATED NEMA 1 (OR BETTER) FOR INTERIOR LOCATIONS AND WEATHER PROTECTED (WP OR BETTER) FOR EXTERIOR LOCATIONS.
27. THE CONTRACTOR SHALL NOTIFY AND OBTAIN NECESSARY AUTHORIZATION FROM THE CARRIER AND/OR DISH Wireless L.L.C. AND TOWER OWNER BEFORE COMMENCING WORK ON THE AC POWER DISTRIBUTION PANELS.
28. THE CONTRACTOR SHALL PROVIDE NECESSARY TAGGING ON THE BREAKERS, CABLES AND DISTRIBUTION PANELS IN ACCORDANCE WITH THE APPLICABLE CODES AND STANDARDS TO SAFEGUARD LIFE AND PROPERTY.
29. INSTALL LAMICOID LABEL ON THE METER CENTER TO SHOW "DISH Wireless L.L.C.".
30. ALL EMPTY/SPARE CONDUITS THAT ARE INSTALLED ARE TO HAVE A METERED MULE TAPE PULL CORD INSTALLED.



5701 SOUTH SANTA FE DRIVE
LITTLETON, CO 80120



45 BEECHWOOD DRIVE TEL: (978) 557-5553
N. ANDOVER, MA 01845 FAX: (978) 336-5586



IT IS A VIOLATION OF LAW FOR ANY PERSON, UNLESS THEY ARE ACTING UNDER THE DIRECTION OF A LICENSED PROFESSIONAL ENGINEER, TO ALTER THIS DOCUMENT.

DRAWN BY:	CHECKED BY:	APPROVED BY:
PS	SMA	DPH

RFDS REV #: 0

PRELIMINARY DOCUMENTS

SUBMITTALS		
REV	DATE	DESCRIPTION
A	11/15/2021	ISSUED FOR REVIEW
B	01/21/2022	ISSUED FOR REVIEW

A&E PROJECT NUMBER
BOBOS00592A

DISH Wireless L.L.C.
PROJECT INFORMATION
BOBOS00592A
CROWN CASTLE BU#841273
344 ROUTE 6
NORTH TRURO, MA 02652

SHEET TITLE
GENERAL NOTES

SHEET NUMBER
GN-3

GROUNDING NOTES:

1. ALL GROUND ELECTRODE SYSTEMS (INCLUDING TELECOMMUNICATION, RADIO, LIGHTNING PROTECTION AND AC POWER GES'S) SHALL BE BONDED TOGETHER AT OR BELOW GRADE, BY TWO OR MORE COPPER BONDING CONDUCTORS IN ACCORDANCE WITH THE NEC.
2. THE CONTRACTOR SHALL PERFORM IEEE FALL-OF-POTENTIAL RESISTANCE TO EARTH TESTING (PER IEEE 1100 AND 81) FOR GROUND ELECTRODE SYSTEMS, THE CONTRACTOR SHALL FURNISH AND INSTALL SUPPLEMENTAL GROUND ELECTRODES AS NEEDED TO ACHIEVE A TEST RESULT OF 5 OHMS OR LESS.
3. THE CONTRACTOR IS RESPONSIBLE FOR PROPERLY SEQUENCING GROUNDING AND UNDERGROUND CONDUIT INSTALLATION AS TO PREVENT ANY LOSS OF CONTINUITY IN THE GROUNDING SYSTEM OR DAMAGE TO THE CONDUIT AND PROVIDE TESTING RESULTS.
4. METAL CONDUIT AND TRAY SHALL BE GROUNDED AND MADE ELECTRICALLY CONTINUOUS WITH LISTED BONDING FITTINGS OR BY BONDING ACROSS THE DISCONTINUITY WITH #6 COPPER WIRE UL APPROVED GROUNDING TYPE CONDUIT CLAMPS.
5. METAL RACEWAY SHALL NOT BE USED AS THE NEC REQUIRED EQUIPMENT GROUND CONDUCTOR. STRANDED COPPER CONDUCTORS WITH GREEN INSULATION, SIZED IN ACCORDANCE WITH THE NEC, SHALL BE FURNISHED AND INSTALLED WITH THE POWER CIRCUITS TO BTS EQUIPMENT.
6. EACH CABINET FRAME SHALL BE DIRECTLY CONNECTED TO THE MASTER GROUND BAR WITH GREEN INSULATED SUPPLEMENTAL EQUIPMENT GROUND WIRES, #6 STRANDED COPPER OR LARGER FOR INDOOR BTS; #2 BARE SOLID TINNED COPPER FOR OUTDOOR BTS.
7. CONNECTIONS TO THE GROUND BUS SHALL NOT BE DOUBLED UP OR STACKED BACK TO BACK CONNECTIONS ON OPPOSITE SIDE OF THE GROUND BUS ARE PERMITTED.
8. ALL EXTERIOR GROUND CONDUCTORS BETWEEN EQUIPMENT/GROUND BARS AND THE GROUND RING SHALL BE #2 SOLID TINNED COPPER UNLESS OTHERWISE INDICATED.
9. ALUMINUM CONDUCTOR OR COPPER CLAD STEEL CONDUCTOR SHALL NOT BE USED FOR GROUNDING CONNECTIONS.
10. USE OF 90° BENDS IN THE PROTECTION GROUNDING CONDUCTORS SHALL BE AVOIDED WHEN 45° BENDS CAN BE ADEQUATELY SUPPORTED.
11. EXOTHERMIC WELDS SHALL BE USED FOR ALL GROUNDING CONNECTIONS BELOW GRADE.
12. ALL GROUND CONNECTIONS ABOVE GRADE (INTERIOR AND EXTERIOR) SHALL BE FORMED USING HIGH PRESS CRIMPS.
13. COMPRESSION GROUND CONNECTIONS MAY BE REPLACED BY EXOTHERMIC WELD CONNECTIONS.
14. ICE BRIDGE BONDING CONDUCTORS SHALL BE EXOTHERMICALLY BONDED OR BOLTED TO THE BRIDGE AND THE TOWER GROUND BAR.
15. APPROVED ANTIOXIDANT COATINGS (i.e. CONDUCTIVE GEL OR PASTE) SHALL BE USED ON ALL COMPRESSION AND BOLTED GROUND CONNECTIONS.
16. ALL EXTERIOR GROUND CONNECTIONS SHALL BE COATED WITH A CORROSION RESISTANT MATERIAL.
17. MISCELLANEOUS ELECTRICAL AND NON-ELECTRICAL METAL BOXES, FRAMES AND SUPPORTS SHALL BE BONDED TO THE GROUND RING, IN ACCORDANCE WITH THE NEC.
18. BOND ALL METALLIC OBJECTS WITHIN 6 ft OF MAIN GROUND RING WITH (1) #2 BARE SOLID TINNED COPPER GROUND CONDUCTOR.
19. GROUND CONDUCTORS USED FOR THE FACILITY GROUNDING AND LIGHTNING PROTECTION SYSTEMS SHALL NOT BE ROUTED THROUGH METALLIC OBJECTS THAT FORM A RING AROUND THE CONDUCTOR, SUCH AS METALLIC CONDUITS, METAL SUPPORT CLIPS OR SLEEVES THROUGH WALLS OR FLOORS. WHEN IT IS REQUIRED TO BE HOUSED IN CONDUIT TO MEET CODE REQUIREMENTS OR LOCAL CONDITIONS, NON-METALLIC MATERIAL SUCH AS PVC CONDUIT SHALL BE USED. WHERE USE OF METAL CONDUIT IS UNAVOIDABLE (i.e., NONMETALLIC CONDUIT PROHIBITED BY LOCAL CODE) THE GROUND CONDUCTOR SHALL BE BONDED TO EACH END OF THE METAL CONDUIT.
20. ALL GROUNDS THAT TRANSITION FROM BELOW GRADE TO ABOVE GRADE MUST BE #2 BARE SOLID TINNED COPPER IN 3/4" NON-METALLIC, FLEXIBLE CONDUIT FROM 24" BELOW GRADE TO WITHIN 3" TO 6" OF CAD-WELD TERMINATION POINT. THE EXPOSED END OF THE CONDUIT MUST BE SEALED WITH SILICONE CAULK. (ADD TRANSITIONING GROUND STANDARD DETAIL AS WELL).
21. BUILDINGS WHERE THE MAIN GROUNDING CONDUCTORS ARE REQUIRED TO BE ROUTED TO GRADE, THE CONTRACTOR SHALL ROUTE TWO GROUNDING CONDUCTORS FROM THE ROOFTOP, TOWERS, AND WATER TOWERS GROUNDING RING, TO THE EXISTING GROUNDING SYSTEM, THE GROUNDING CONDUCTORS SHALL NOT BE SMALLER THAN 2/0 COPPER. ROOFTOP GROUNDING RING SHALL BE BONDED TO THE EXISTING GROUNDING SYSTEM, THE BUILDING STEEL COLUMNS, LIGHTNING PROTECTION SYSTEM, AND BUILDING MAIN WATER LINE (FERROUS OR NONFERROUS METAL PIPING ONLY). DO NOT ATTACH GROUNDING TO FIRE SPRINKLER SYSTEM PIPES.



5701 SOUTH SANTA FE DRIVE
LITTLETON, CO 80120



45 BEECHWOOD DRIVE TEL: (978) 557-5553
N. ANDOVER, MA 01845 FAX: (978) 336-5586

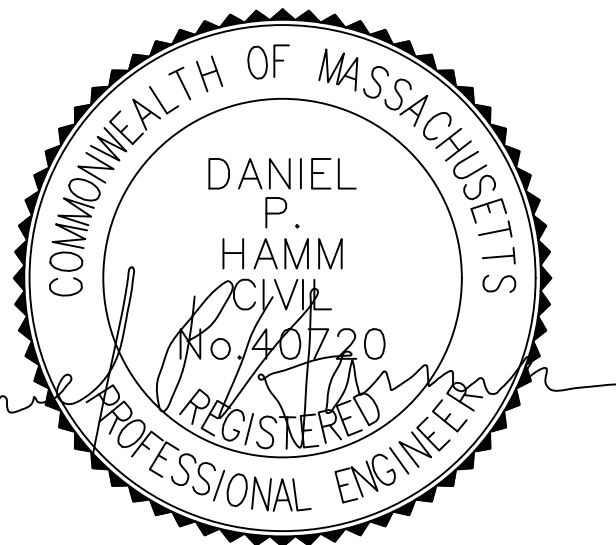

IT IS A VIOLATION OF LAW FOR ANY PERSON, UNLESS THEY ARE ACTING UNDER THE DIRECTION OF A LICENSED PROFESSIONAL ENGINEER, TO ALTER THIS DOCUMENT.

DRAWN BY:	CHECKED BY:	APPROVED BY:
PS	SMA	DPH

RFDS REV #: 0

PRELIMINARY DOCUMENTS

SUBMITTALS		
REV	DATE	DESCRIPTION
A	11/15/2021	ISSUED FOR REVIEW
B	01/21/2022	ISSUED FOR REVIEW

A&E PROJECT NUMBER
BOBOS00592A

DISH Wireless L.L.C.
PROJECT INFORMATION
BOBOS00592A
CROWN CASTLE BU#841273
344 ROUTE 6
NORTH TRURO, MA 02652

SHEET TITLE
GENERAL NOTES

SHEET NUMBER
GN-4



Town of Truro Planning Board

P.O. Box 2030, Truro, MA 02666

FORM A

APPLICATION FOR DETERMINATION THAT PLAN DOES NOT REQUIRE APPROVAL (ANR)

To the Planning Board of the Town of Truro, MA

Date SEPTEMBER 30, 2022

The undersigned owners of all the land described herein submitted the accompanying plan entitled: PLAN OF LAND IN TRURO, AS SUBDIVIDED FOR MATTHEW D. DEARBLE & MURRAY J. BARRETT and dated AUGUST 8, 2022, requests a determination and endorsement by said Board that approval by it under the Subdivision Control Law is not required.

Property Location: 31 & 33 SYLVAN LAKE Map(s) and Parcel(s): MAP 43 PARCELS 74 & 75

Number of Lots Created: ONE Total Land Area: 119,690 ± sq. Ft. 2.742 ± acres

The owner's title to said land is derived under deed from © JULIANNE BRITT dated JUNE 14, 2022 and recorded in the Barnstable Registry of Deeds Book and Page 35191 / 48 or 33389 / 120 or Land Court Certificate of Title No. N.A. registered in Barnstable County.

The undersigned believes that such approval is not required for the following reasons: (check as appropriate)

- The accompanying plan is not a subdivision because the plan does not show a division of land.
- The division of the tract of land shown on the accompanying plan is not a subdivision because every lot shown on the plan has frontage of at least such distance as is presently required by the Truro Zoning Bylaw under Section 50.1(A) which requires 150 feet for erection of a building on such lot; and every lot shown on the plan has such frontage on:
 - a public way or way which the Town Clerk certifies is maintained and used as a public way, namely _____, or
 - a way shown on a plan theretofore approved and endorsed in accordance with the subdivision control law, namely _____ on _____ and subject to the following conditions _____; or
 - a private way in existence on December 8, 1955, the date when the subdivision control law became effective in the Town of Truro having, in the opinion of the Planning Board, sufficient width, suitable grades, and adequate construction to provide for the needs of vehicular traffic in relation to the proposed use of the land abutting thereon or served thereby, and for the installation of municipal services to serve such land and the buildings erected or to be erected thereon, namely _____.
- The division of the tract of land shown on the accompanying plan is not a "subdivision" because it shows a proposed conveyance/other instrument, namely REMOVING AND INVERTING LOT LINE AND COMBINING INTO LOT which adds to/takes away from/changes the size and shape of, lots in such a manner that no lot affected is left without frontage as required by the Truro Zoning Bylaw under Section 50.1(A), which requires 150 feet.

The division of the tract of land shown on the accompanying plan is not a subdivision because two or more buildings, specifically _____ buildings were standing on the property prior to December 8, 1955, the date when the subdivision control law went into effect in the Town of Truro and one of such buildings remains standing on each of the lots/said buildings as shown and located on the accompanying plan. Evidence of the existence of such buildings prior to the effective date of the subdivision control law as follows:

Other reasons or comments: (See M.G. L., c.41, §81-L)

All other information as required in the Rules and Regulations Governing Subdivisions of Land shall be submitted as part of the application.

* MATTHEW D. BRAMBLE
(Printed Name of Owner)

Matthew D. Bramble
(Signature)

* MURRAY J. BARTLETT
(Printed Name of Owner)

Murray J. Bartlett
(Signature)

P.O. BOX 483 Provincetown, MA 02657
(Address of Owner(s))

(Address of Owner(s))

WILLIAM N. ROGERS II
(Printed Name of Agent)

William N. Rogers II
(Signature)

4 LOFF CEMENTERY ROAD, P.O. BOX 631, PROVINCETOWN, MA 02657
(Address of Agent)

File twelve (12) copies each of this form and applicable plan(s) with the Town Clerk; and a complete copy, including all plans and attachments, submitted electronically to the Town Planner at planner1@truro-ma.gov

From: [Billy Rogers](#)
To: [Elizabeth Sturdy](#)
Subject: Re: 31, 33 Sylvan Lane, Truro - Subdivision Plan A.N. R.
Date: Friday, October 7, 2022 11:50:46 AM

Ms. Anne Greenbaum, Chairman
Truro Planning Board
Town Hall
Truro, Massachusetts

Re: Sylvan Lane
Truro, Massachusetts

Dear Ms. Greenbaum:

Pursuant to your recent request regarding the Status of Condition of the Travelled Surface on Sylvan Lane, I have performed a visual inspection this date and am presenting my findings forthwith:

Please be advised of the following:

1. The "Sylvia Epstein" Subdivision Plan was Approved by the Truro Planning Board on May 24, 1966.
2. The existing Traveled Surface is Pavement in front of 33 Sylvan Lane.
3. Sylvan Lane is a long Subdivision Road. It exists of a dense graded crushed stone / gravel & hardening surface from entrance at Whitmanville Road to our Locus.
4. There did not appear to be any Drainage Structures in-place.

If I can be of any further assistance to you on this matter, please do not hesitate to contact me.

Respectfully submitted,

William N. Rogers II, PE, PLS

2.2 - APPROVAL NOT REQUIRED (ANR) PLAN ENDORSEMENT REVIEW CHECKLIST - Applicant

Address: 31833 Sylvan Lane, Truro Applicant Name: William N. Roberts II Date: September 30, 2022

No.	Requirement	Included	Not Included	Explanation, if needed
2.2.2 Submission Requirements				
Any person may submit a plan seeking endorsement that the plan does not require approval under the Subdivision Control Law by providing the Board with the following:				
a.	A properly executed application for Approval Not Required Endorsement (Form A).	✓		
b.	Ten (10) paper prints of the plan. Said plan shall be prepared in such a manner as to meet the Registry of Deeds and/or Land Court requirements for recording and shall contain the following information:	✓		
b.1	The boundaries, area, frontage and dimensions of the lot or lots for which ANR endorsement is sought.	✓		
b.2	The date of the plan, scale, north arrow and assessor's map and parcel number of all land shown on the plan and directly abutting the land shown on the plan.	✓		
b.3	The name(s) of the owner(s) of record of the lots shown on the plan and of the applicant, together with the name, address seal and signature of the land surveyor who prepared the plan.	✓		
b.4	Relevant zoning classification data.			
b.5	A locus plan containing sufficient information to locate the land and showing streets bounding or providing access to the property.	✓		
b.6	The name(s) of the way(s) on which the lots front, information as to ownership of the way(s) and the physical condition of the way(s) including actual width, surface type and condition.	✓		
b.7	The location and dimension of any natural features which might affect the use of the frontage for access.	✓		
b.8	The location, including setbacks to all lot lines, of all buildings and other structures on the proposed ANR lots shown on the plan.	✓		
b.9	The location of any wetland on the land shown on the plan or within one hundred (100) feet of its boundaries.	✓		
b.10	The location of all bounds and easements on the proposed ANR lots shown on the plan.	✓		

2.2 - APPROVAL NOT REQUIRED (ANR) PLAN ENDORSEMENT REVIEW CHECKLIST - Applicant

Address: 3433 Sylvan Lane, TROY Applicant Name: [Signature] Date: September 30, 2022

No.	Requirement	Included	Not Included	Explanation, if needed
b.11	The statement "Approval under the Subdivision Control Law Not Required", and sufficient space for the date of the application submittal and the date of endorsement, docket number and the signatures of all Board members.	✓		
b.12	The statement "Planning Board endorsement of this plan indicates only that the plan is not a subdivision under MGL, Chapter 41, Section 81-L and does not indicate that a lot is buildable or that it meets Zoning, Health or General Bylaw requirements."	✓		

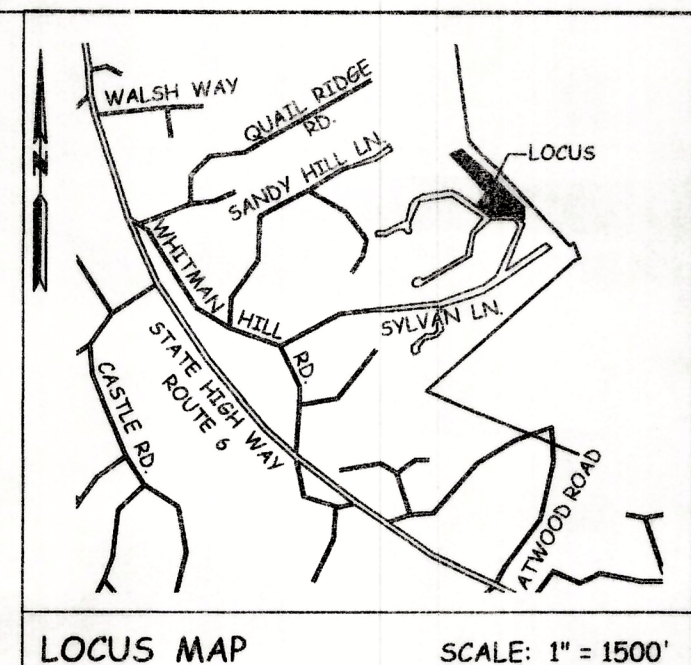

ORIN KIMBALL & LAURA MALEY
 LOTS 6 & 6A
 PLAN BOOK 562 PAGE 9
 PLAN BOOK 550 PAGE 82
 (NO. 9 SANDY LANE)
 ASSESSOR'S MAP 43 PARCEL 200

MARK P. & CINDY FOX
 LOT 10
 PLAN BOOK 203 PAGE 115
 (NO. 37 SYLVAN LANE)
 ASSESSOR'S MAP 43 PARCEL 66

KIBI L. SHULTZ &
 CHRISTIAN J.
 BAINBRIDGE
 LOT 9
 PLAN BOOK 203 PAGE 115
 (NO. 35 SYLVAN LANE)
 ASSESSOR'S MAP 43 PARCEL 72

JENNIFER L. &
 PATRICK F. MULLINS
 LOTS 17C & 17E
 PLAN BOOK 345 PAGE 72
 (NO. 30 SYLVAN LANE)
 ASSESSOR'S MAP 43 PARCEL 71

CHRISTINE D. WELLS
 REVOCABLE TRUST
 LOTS 17D & 17F
 PLAN BOOK 345 PAGE 72
 (NO. 28 SYLVAN LANE)
 ASSESSOR'S MAP 43 PARCEL 73

THE TRURO CONSERVATION TRUST
 LOT 7
 PLAN BOOK 203 PAGE 115
 (NO. 26 SYLVAN LANE)
 ASSESSOR'S MAP 43 PARCEL 91

HENRY & JOSEPHINE
 YUREK
 LOT 1
 PLAN BOOK 221 PAGE 25
 (NO. 29 SYLVAN LANE)
 ASSESSOR'S MAP 43 PARCEL 98

HENRY & JOSEPHINE
 YUREK
 LOT 2
 PLAN BOOK 478 PAGE 22
 (NO. 6 NELSON DRIVE)
 ASSESSOR'S MAP 43 PARCEL 181

UNITED STATES NATIONAL OF SEASHORE
 COD NATIONAL OF SEASHORE

LOT 1
 AREA = 88,358± SQ. FT.
 (NO. 31 SYLVAN LANE)

LOT 8A
 AREA = 119,690± SQ. FT.
 = (2.748± acres)

LOT 8
 AREA = 31,332± SQ. FT.
 (NO. 33 SYLVAN LANE)

NOTE: * 31 SYLVAN LANE
 ASSESSOR'S MAP 43 PARCEL 75
 * 33 SYLVAN LANE
 ASSESSOR'S MAP 43 PARCEL 74.

ZONING CLASSIFICATION:
 LOT 8A IS LOCATED IN
 RESIDENTIAL DISTRICT.

ZONING CLASSIFICATION TABLE	
ZONING REQUIREMENT	LOT 8A PROPOSED
LOT SIZE 33,750± SQ. FT.	119,690± SQ. FT.
MIN. FRONTAGE 150 FT.	461.02 FT.
FRONT YD. SETBACK 25 FT.	N.A.
SIDE YD. SETBACK 25 FT.	N.A.
LOT COVERAGE	N.A.
WETLAND AREA	- 0 -

NOTE: PLANNING BOARD ENDORSEMENT OF THIS PLAN INDICATES ONLY THAT THE PLAN IS NOT A SUBDIVISION UNDER MGL, CHAPTER 41, SECTION 81-L AND DOES NOT INDICATE THAT A LOT IS BUILDABLE OR THAT IT MEETS ZONING, HEALTH OR GENERAL BYLAW REQUIREMENTS.

I CERTIFY THAT THIS PLAN HAS BEEN PREPARED IN CONFORMITY WITH THE RULES AND REGULATIONS OF THE REGISTERS OF DEEDS OF THE COMMONWEALTH OF MASSACHUSETTS.

August 8, 2022

APPROVAL UNDER THE SUBDIVISION CONTROL LAW NOT REQUIRED.
 REF. CHAP. 41 SEC. 81-P, 6L.:

TRURO PLANNING BOARD:

DATE: _____

LEGEND:
 D.M.H. = DRAINAGE MANHOLE
 M.H. = MANHOLE
 S.M.H. = SEWER MANHOLE
 W.G. = WATER GATE
 T.P. = UTILITY POLE
 U/G = UNDERGROUND
 L.P. = LIQUID PROPANE

NOTE: ALL BUILDING OFFSETS ARE MEASURED PERPENDICULAR TO THE PROPERTY LINES.

NOTE: () DENOTES RECORD INFORMATION.

REFERENCE: PLAN BOOK 478 PAGE 22
 PLAN BOOK 203 PAGE 115
 DEED BOOK 35191 PAGE 48
 DEED BOOK 33585 PAGE 120

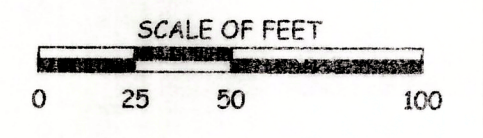

PLAN OF LAND
 IN
 TRURO
 AS SURVEYED FOR

MATTHEW D. BRAMBLE &
 MURRAY J. BARTLETT

SCALE: 1 IN. = 50 FT. AUGUST, 2022

WILLIAM N. ROGERS
 PROFESSIONAL
 CIVIL ENGINEERS & LAND SURVEYORS
 41 OFF CEMETERY ROAD, PROVINCETOWN, MASS.
 508.487.1565 / 508.487.5809 FAX

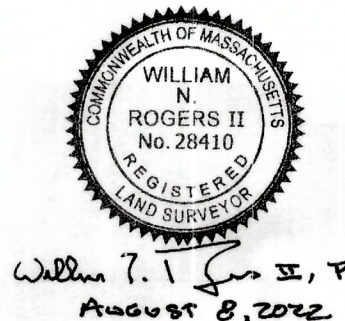

William N. Rogers II, PE, LS
 August 8, 2022

NOTE: LOT 8 & LOT 1 ARE TO BE COMBINED TO FORM LOT 8A.

TRURO PLANNING BOARD
Work Session September 28, 2022

Minutes

Attending: Anne Greenbaum – Chair; Rich Roberts – Vice Chair; Jack Riemer – Clerk; Paul Kiernan, Ellery Althaus, Caitlin Townsend – Members; Barbara Carboni – Town Planner & Land Use Counsel

- 1) Discussion of Term Length for Charter Review Committee meeting November 17, 2022
 - Question – why is the term 5 years?
 - When Planning Board establish Select Board suggested 5 members for staggered 5-year terms
 - Comments
 - Sometimes institutional memory guides Boards, with 3-year terms can lose that
 - Member 1.9 years – originally the 5-year term was daunting, now doesn't seem that way, need the time, there is steep learning curve. 5 years, maybe 4
 - Member 1.5 years – learning & getting the hang of it. 3 feels short – 5, maybe 4
 - 10 year member – time goes by fast, never enough time to learn everything
 - Maybe add alternate members to try out planning board, start learning
 - State law – 5-9 members, elected or appointed
- 2) Review Draft 2023 Calendar
 - 1 change – change 1st September meeting from September 6 to September 13.
- 3) Interviews for open Planning Board position
 - All members available October 25, 2022
 - Question – will new Select Board appointment policy be in effect?
 - Chair to coordinate with Select Board chair concerning interview logistics/structure
 - Members to bring potential questions to next Select Board meeting
- 4) Date for Review of Housing Production Plan
 - Preference to not do as part of regular Planning Board meeting but to have separate meeting
 - Confirmed availability of all for Thursday December 8 4:15/4:30 pm
- 5) Potential Warrant Articles – Decisions on whether to continue and if so next steps
 - Driveway grades – Select Board passed new curb cut policy earlier this year that somewhat addresses this.
 - i. Planning Board will not propose bylaw change

- Street Definition – Rich Robert has been researching this issue and has put together document with: past attempts, history, identified major issue, and examples from other Cape towns.
 - i. Planning Board will continue to develop potential warrant article
 - ii. Next steps –
 - Chair to talk with John Dundas, Select Board liaison about early Select Board input
 - Identified others to engage now
 - Report to all Board members
- Lot Coverage/Site Clearing – Paul Kiernan presented update, with information on other towns efforts.
 - i. Planning Board will continue to develop potential warrant articles
 - ii. Next steps
 - Chair and Member Kiernan to develop 1- or 2-page summary document to send to the following Boards to update them and ask for their input. (Board of Health, Climate Action Committee, Conservation Commission, Open Space Committee, Select Board, Walsh Property Community Planning Committee), Zoning Board of Appeals)
 - Also, will be sent to Emily Beebe – Health & Conservation Agent
- Housing – Board looking at number of potential zoning articles including
 - i. Duplexes
 - ii. Multifamily Structures
 - iii. Mixed Used Structures
 - iv. Overlay District(s)
 - v. Allowing Affordable Housing on Undersize lots and lots that otherwise do not meeting Zoning bylaws (looking at recently passed article in Wellfleet)
 - vi. Ad Hoc housing group informed of this list and discussing these and potential other possibilities.
- Discussion of when to hold community forums on

Next Planning Board Meeting – Wednesday October 12, 2022 at 5 pm

Next Work Session on Warrant Article – Wednesday October 26, 2022

Actions

- Agenda item – enforcing date(s) for supplemental material

Respectfully submitted,

Anne Greenbaum